

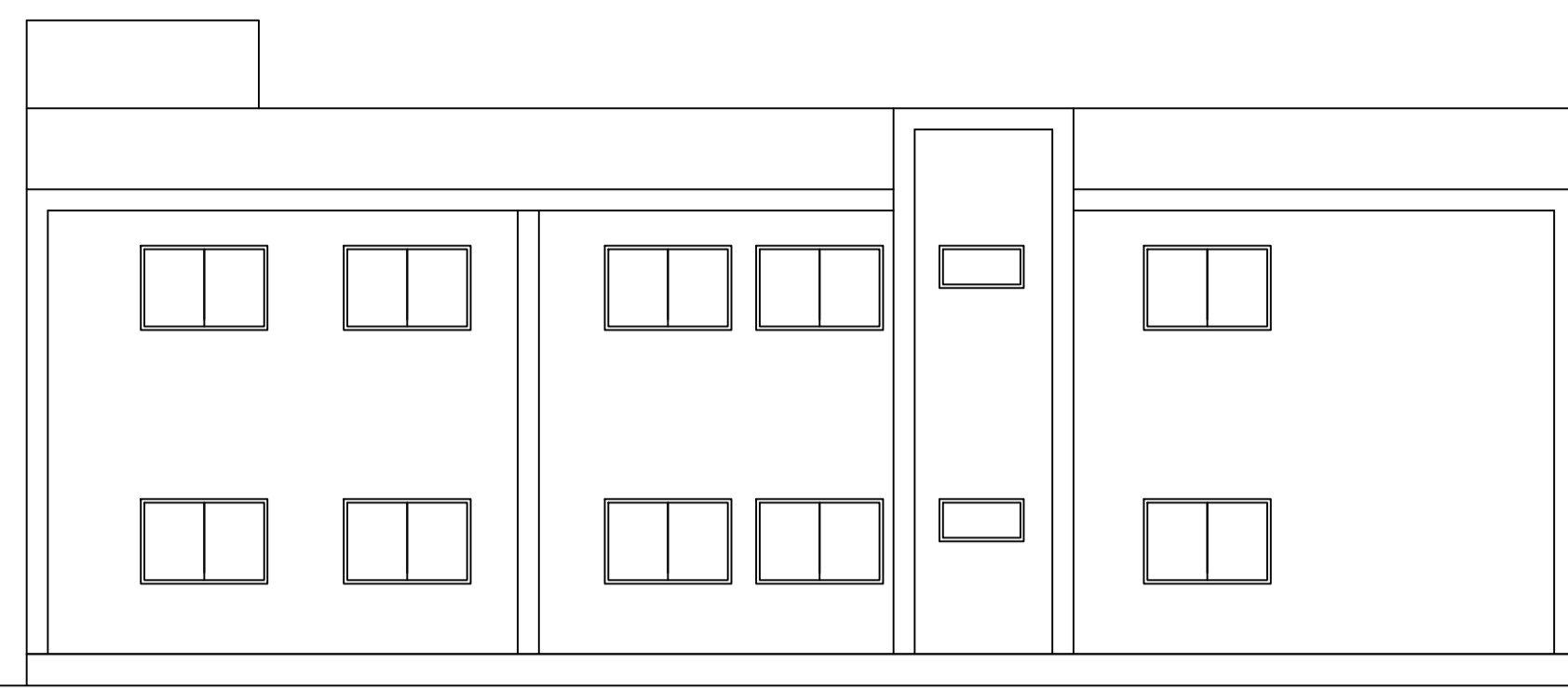

Proposal Basic Information	
Proposal File No.	HNPC/BP/0026/W07/2022
Owner Name	Sushila Devi
Khata No	194
Plot No	677
Village Name	Japla Chaube
Use	Residential
SubUse	Residential Bldg/Apartment

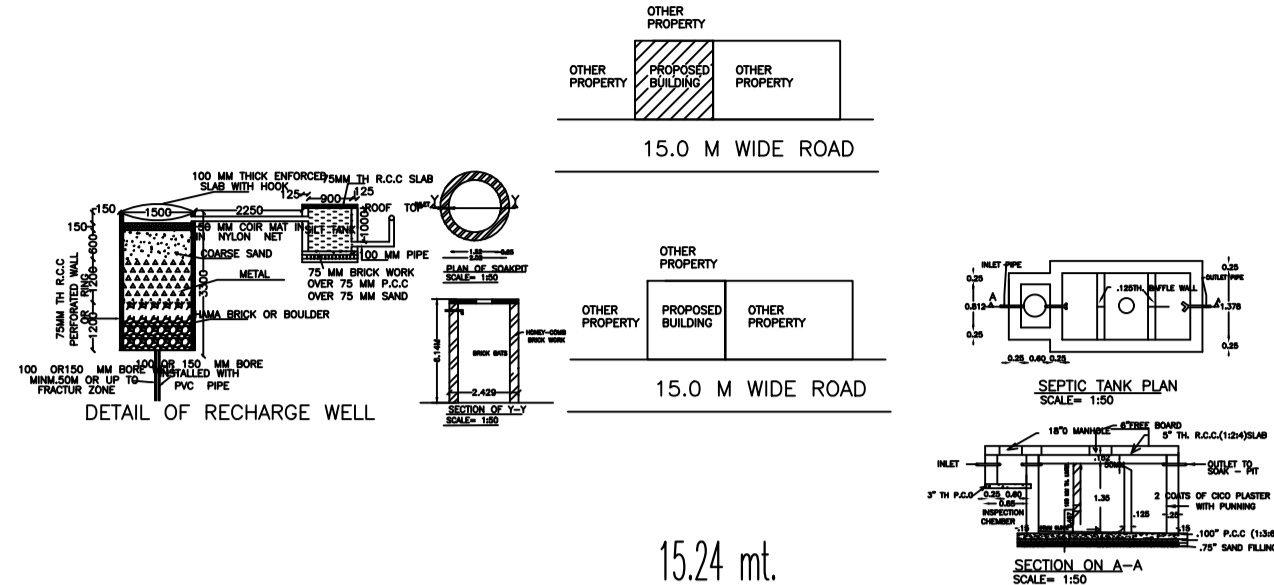

UnitBUA Table for Building :SHSHILA DEVI (HOUSE)

FLOOR	Name	UnitBUA Type	UnitBUA Area	Carpet Area	No. of Rooms	No. of Tenement
GROUND FLOOR PLAN	SPLIT A	FLAT	361.56	361.44	11	1
FIRST FLOOR PLAN	SPLIT A	FLAT	0.00	0.00	11	0
Total:	-	-	361.56	361.44	22	1

SCHEDULE OF DOOR:

BUILDING NAME	NAME	LENGTH	HEIGHT	NOS
SHSHILA DEVI (HOUSE)	D2	0.80	2.10	10
SHSHILA DEVI (HOUSE)	D1	1.00	2.10	10
SHSHILA DEVI (HOUSE)	D	1.20	2.10	01

SCHEDULE OF WINDOW/VENTILATION:

BUILDING NAME	NAME	LENGTH	HEIGHT	NOS
SHSHILA DEVI (HOUSE)	W2	0.90	1.20	02
SHSHILA DEVI (HOUSE)	V	1.20	0.90	08
SHSHILA DEVI (HOUSE)	W1	1.20	1.50	04
SHSHILA DEVI (HOUSE)	W	1.80	1.50	23

Buildingwise Floor FAR Details

Floor Name	SHSHILA DEVI (HOUSE)		Total	
	Proposed Built Up Area (Sq.mt.)	Proposed FAR Area (Sq.mt.)	Total Proposed Built Up Area (Sq.mt.)	Total FAR Area (Sq.mt.)
Ground Floor	202.40	202.40	202.40	202.40
First Floor	202.40	202.40	202.40	202.40
Terrace Floor	0.00	0.00	0.00	0.00
Total :	404.80	404.80	404.80	404.80

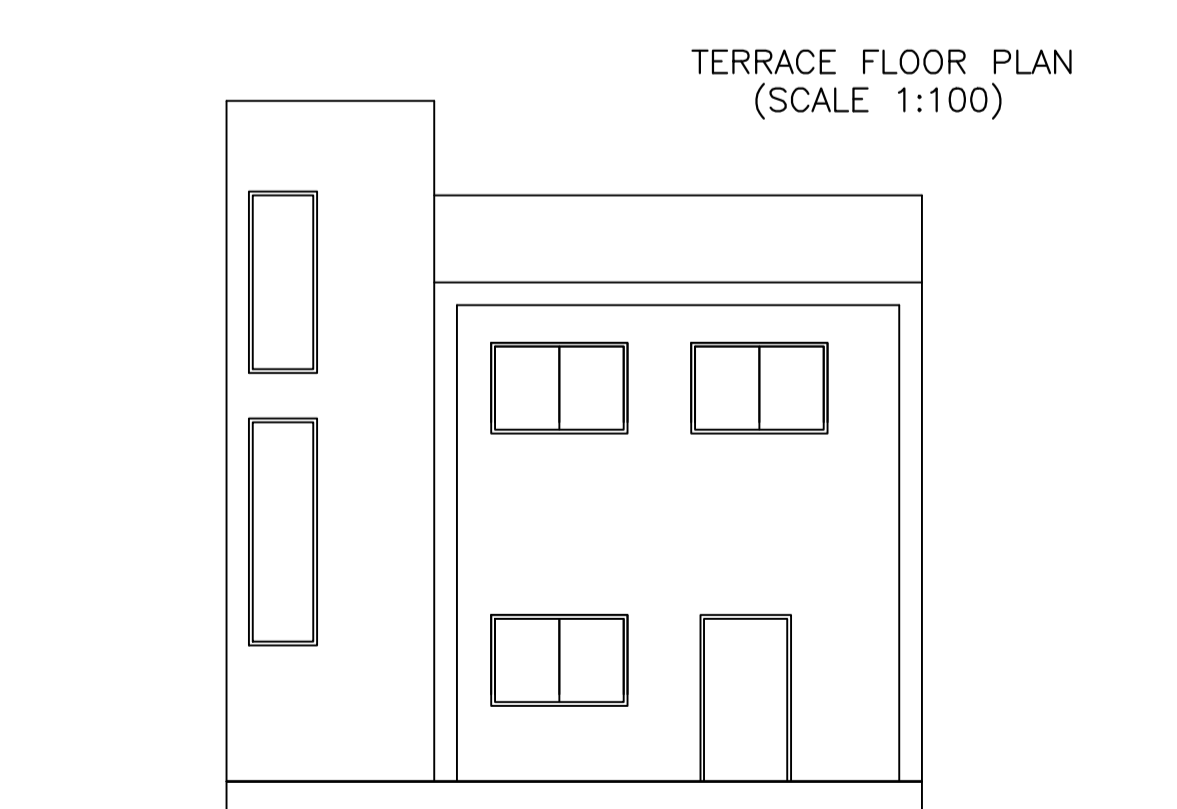
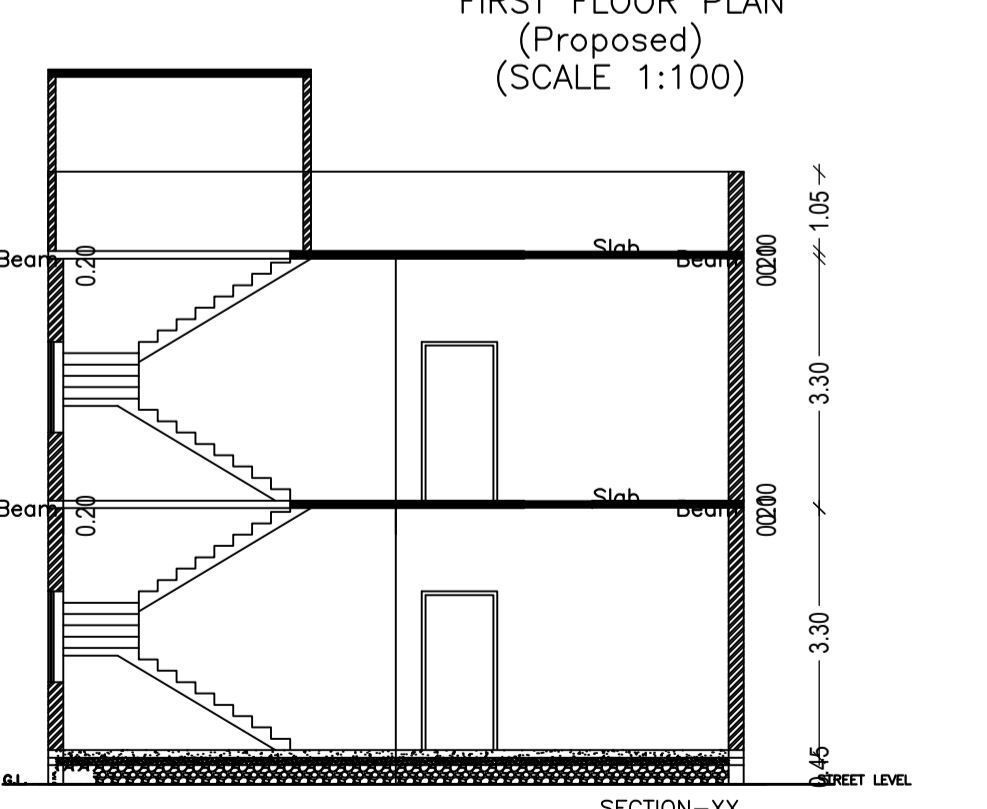
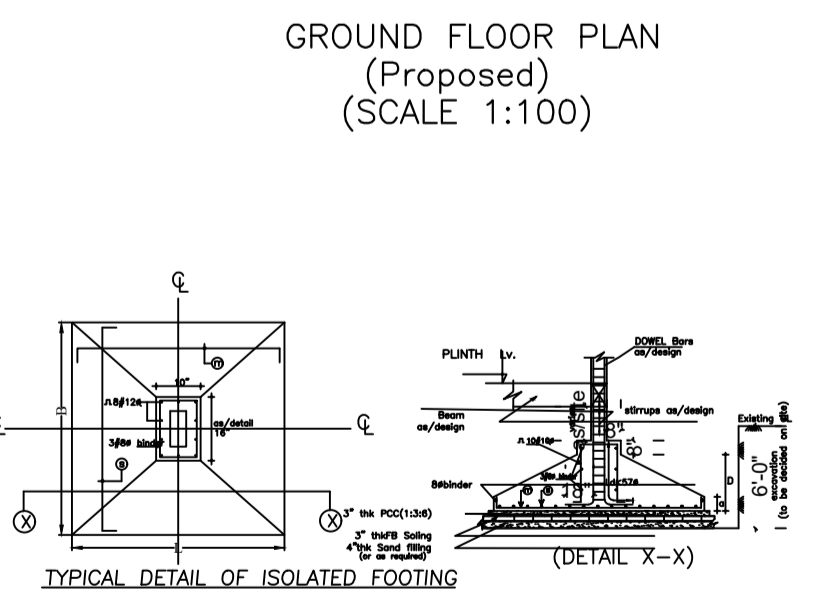
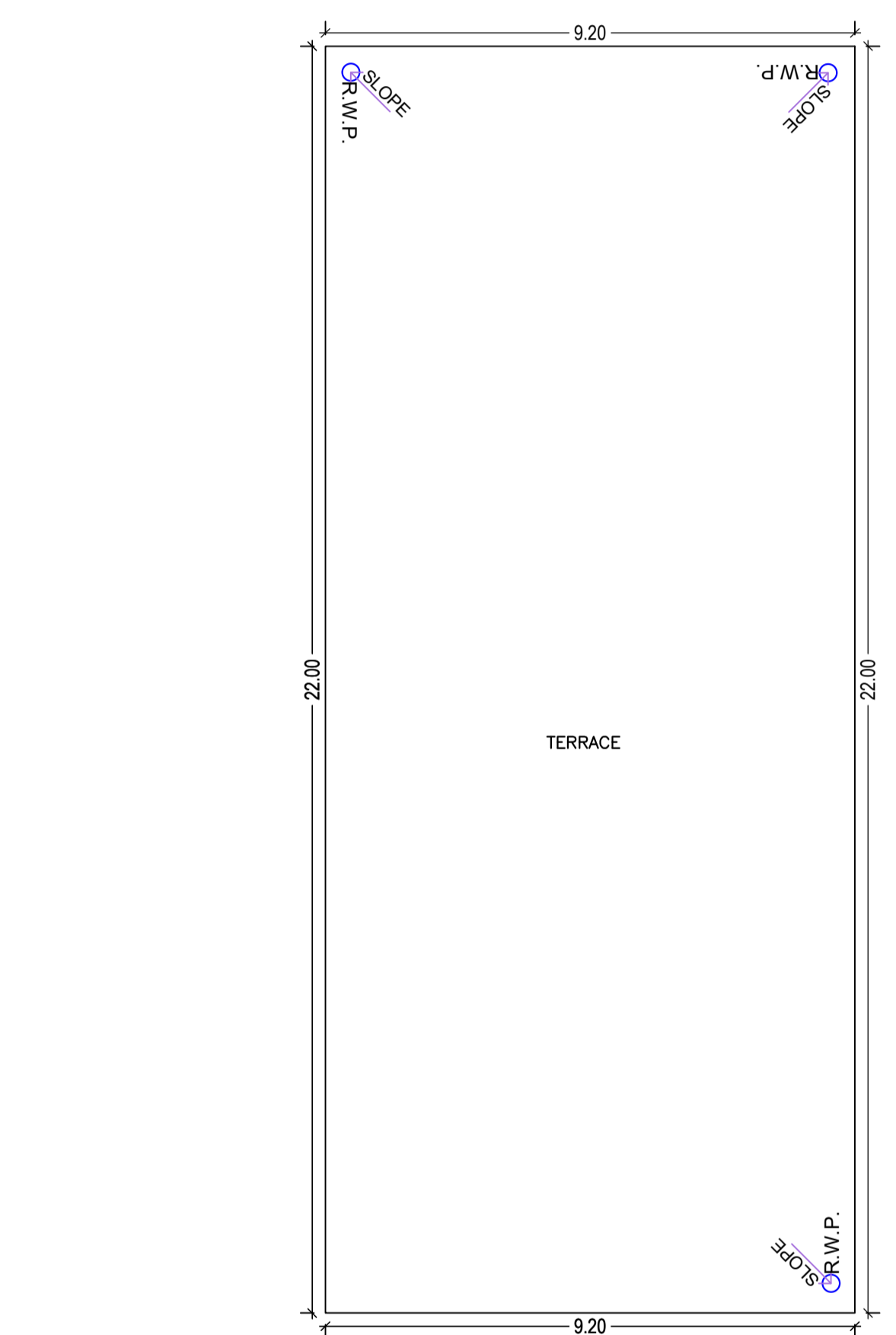
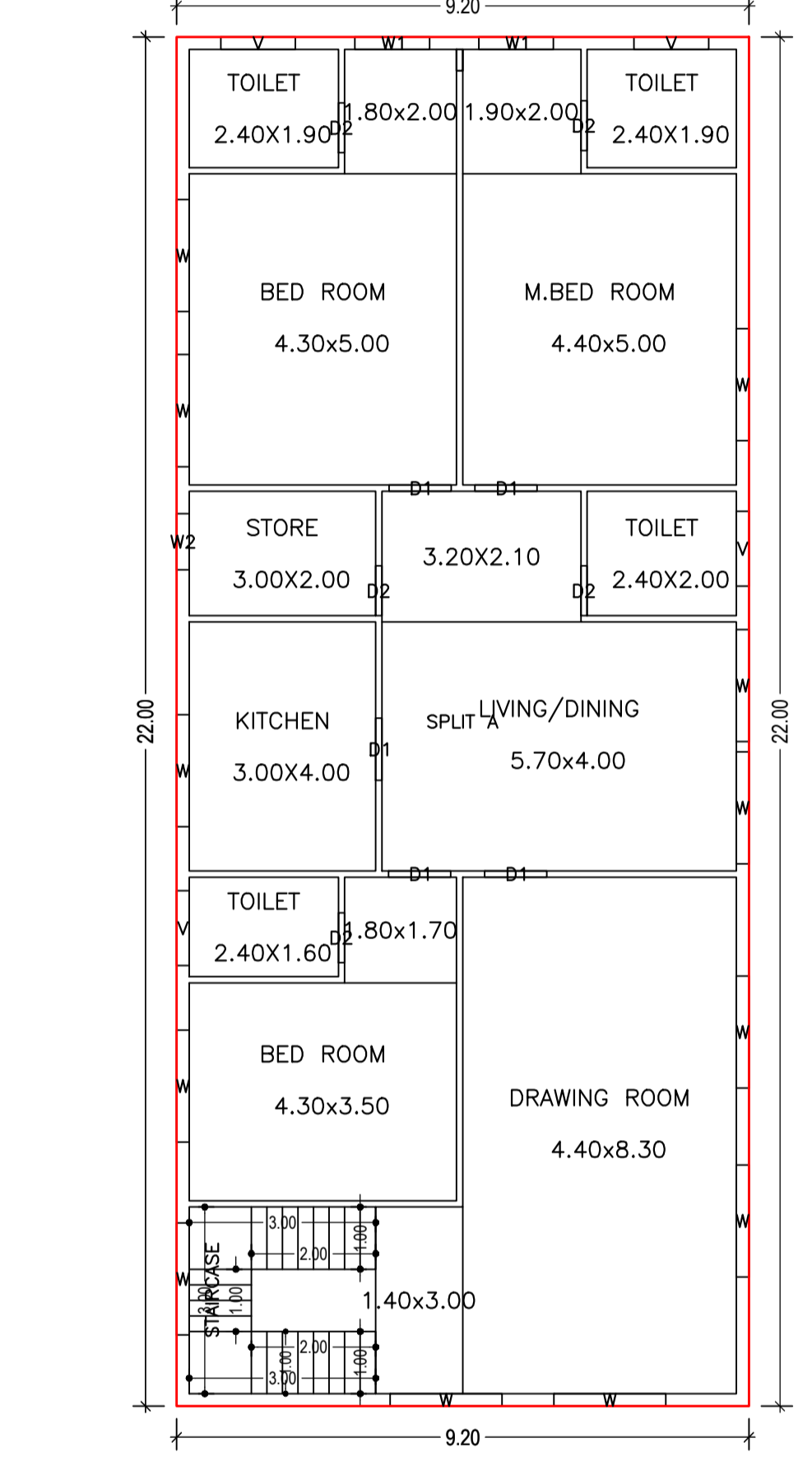
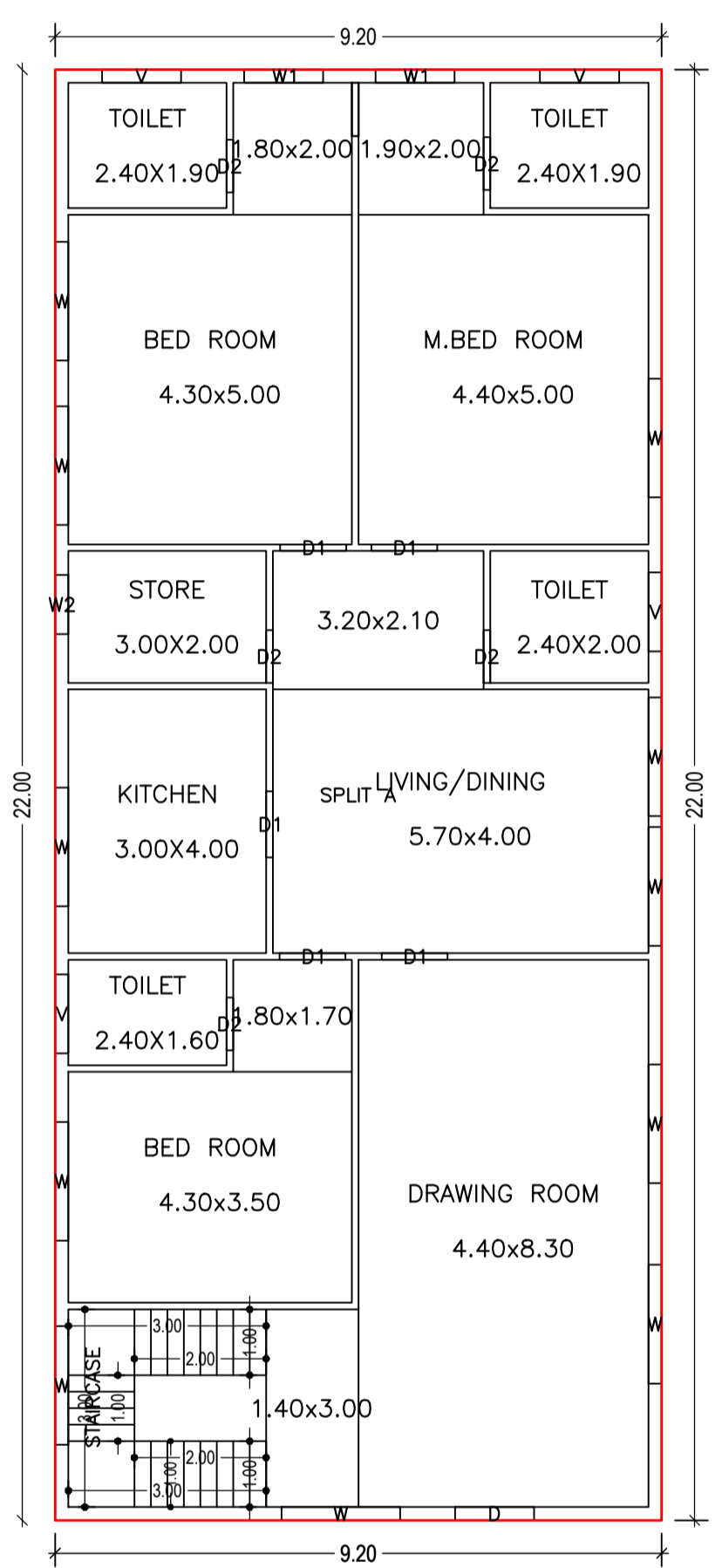
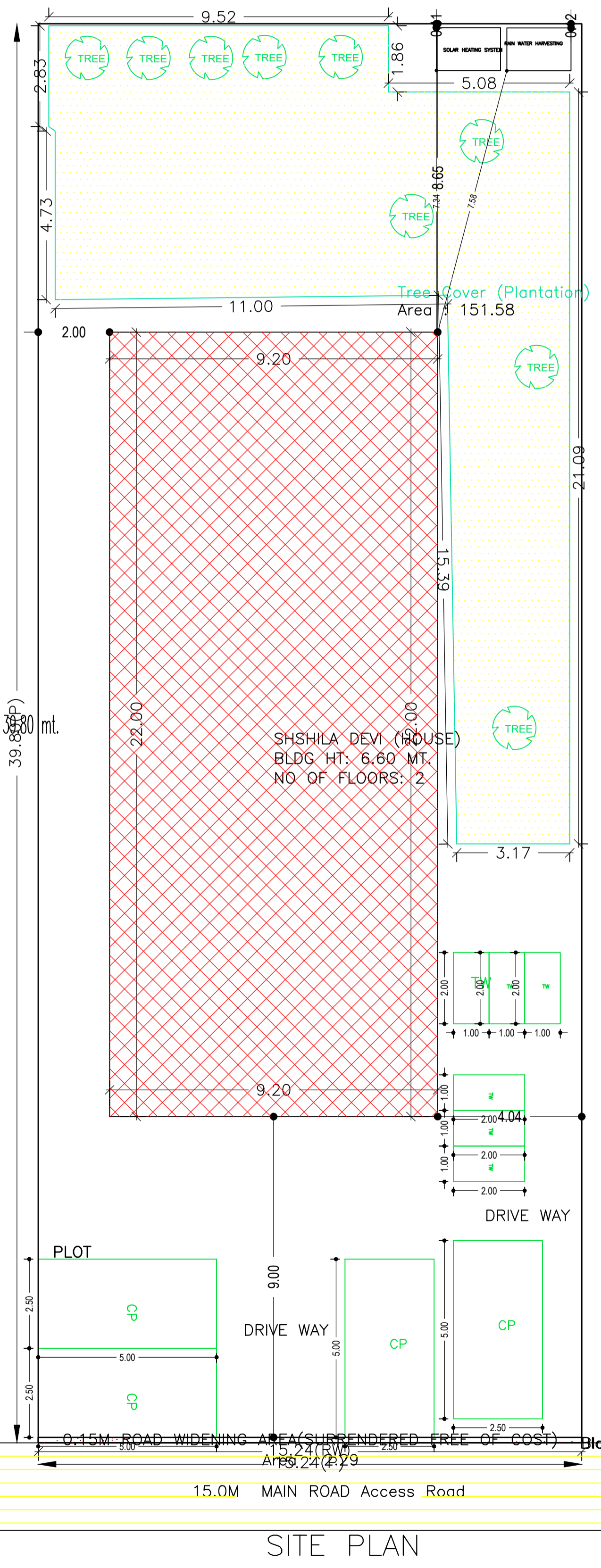

AREA STATEMENT		VERSION NO. : 1.0.65
Hussainabad Nagar Panchayat		VERSION DATE: 16/10/2020
PROJECT DETAIL:		
Region: JHARKHAND URBAN LOCAL BODIES	Plot Use: Residential	
District: PALAMU	Plot SubUse: Residential Bldg/Apartment	
Authority: Hussainabad Nagar Panchayat	Plot/Nearby/Religious Structure: NA	
Inward No: HNPC/BP/0026/W07/2022	Plot/SubPlot No: 677	
Application Type: General Proposal	North: Plot No. - 677	
Project Type: Building Permission	South: Road Width - 15	
Nature of Development: New	East: Plot No. - 677	
Location of Development Area: New Area	West: Plot No. - 677	
AREA DETAILS:		
AREA OF PLOT (Minimum)	(A)	SQ.MT. 606.55
Deduction for NetPlot Area		
Surrender Free of Cost		2.29
Total		2.29
NET AREA OF PLOT(Gross Plot Area - Deduction from Gross Plot area)	(A-Deductions)	604.27
Deduction for Balance Plot Area(from Gross Plot Area)		
Surrender Free of Cost		2.29
Common Plot		151.58
Total		153.87
BALANCE AREA OF PLOT(Net Plot Area - Recreational/Amenity space)	(A-Deductions)	452.69
PLOT AREA FOR COVERAGE(Net Plot Area)	(A-Deductions)	604.27
Plot Area for FAR (Net Plot Area + Road Widening Area)	(A-Deductions)	606.55
COVERAGE CHECK		
Permissible Coverage area (60.00 %)		362.56
Proposed Coverage Area (33.50 %)		202.40
Total Prop. Coverage Area (33.5 %)		202.40
Balance coverage area (26.50 %)		160.16
FAR CHECK		
Perm. FAR Area (2.000)		1213.10
Total Perm. FAR area		1213.10
Residential FAR		404.80
Proposed FAR Area		404.80
Total Proposed FAR Area		404.80
Consumed FAR (Factor)		0.67
Balance FAR Area		808.30
BUILT UP AREA CHECK		
Total Proposed BuiltUp Area		404.80
ARCHITECT (Regd)	Anuj Kumar Paswan	
ENGINEER (Regd)		
SUPERVISOR (Regd)		
OWNER (Regd)	Sushila Devi	
DEVELOPMENT AUTHORITY		LOCAL BODY

Building :SHSHILA DEVI (HOUSE)

Floor Name	Total Built Up Area (Sq.mt.)	Proposed FAR Area (Sq.mt.) Res.	Total FAR Area (Sq.mt.)	Total Consumed Additional FAR Area (Sq.mt.)	Trmnt (No.)
Ground Floor	202.40	202.40	202.40	202.40	01
First Floor	202.40	202.40	202.40	202.40	00
Terrace Floor	0.00	0.00	0.00	0.00	00
Total :	404.80	404.80	404.80	404.80	01
Total Number of Same Buildings :	1				
Total :	404.80	404.80	404.80	404.80	01

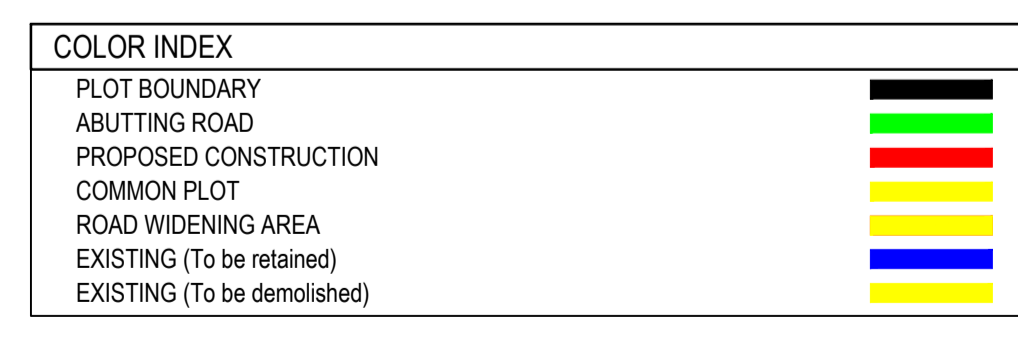

FAR & Tenement Details (Table 4c-1)

Building	No. of Same Bldg	Total Built Up Area (Sq.mt.)	Proposed FAR Area (Sq.mt.) Res.	Total FAR Area (Sq.mt.)	Total Consumed Additional FAR Area (Sq.mt.)	Trmnt (No.)
SHSHILA DEVI (HOUSE)	1	404.80	404.80	404.80	404.80	01
Grand Total :	1	404.80	404.80	404.80	404.80	01

LTP NAME AND SIGNATURE	STRUCTURAL ENG'S NAME AND SIGNATURE	BUILDER NAME AND SIGNATURE	DIGITAL SIGNATURE
Anuj Kumar Paswan HNPC/ENG/002/2022			

Building USE/SUBUSE Details

Building Name	Building Use	Building SubUse	Building Structure
SHSHILA DEVI (HOUSE)	Residential	Bungalow/ Dwelling / Non Apartment	Non-Highrise