

Proposal Basic Information	
Proposal File No.	HNPC/BP/0030/W11/2022
Owner Name	Nilu Devi
Khata No	49
Plot No	601
Village Name	Japla Dharahra
Use	Residential
SubUse	Bungalow/ Dwelling / Non Apartment

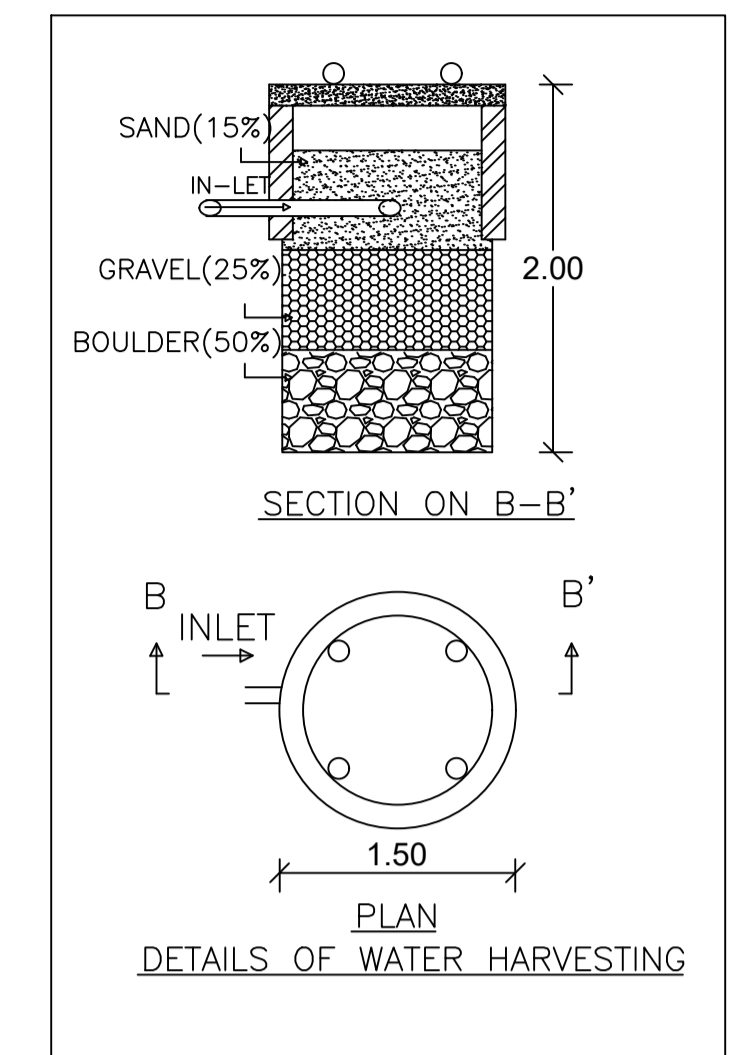
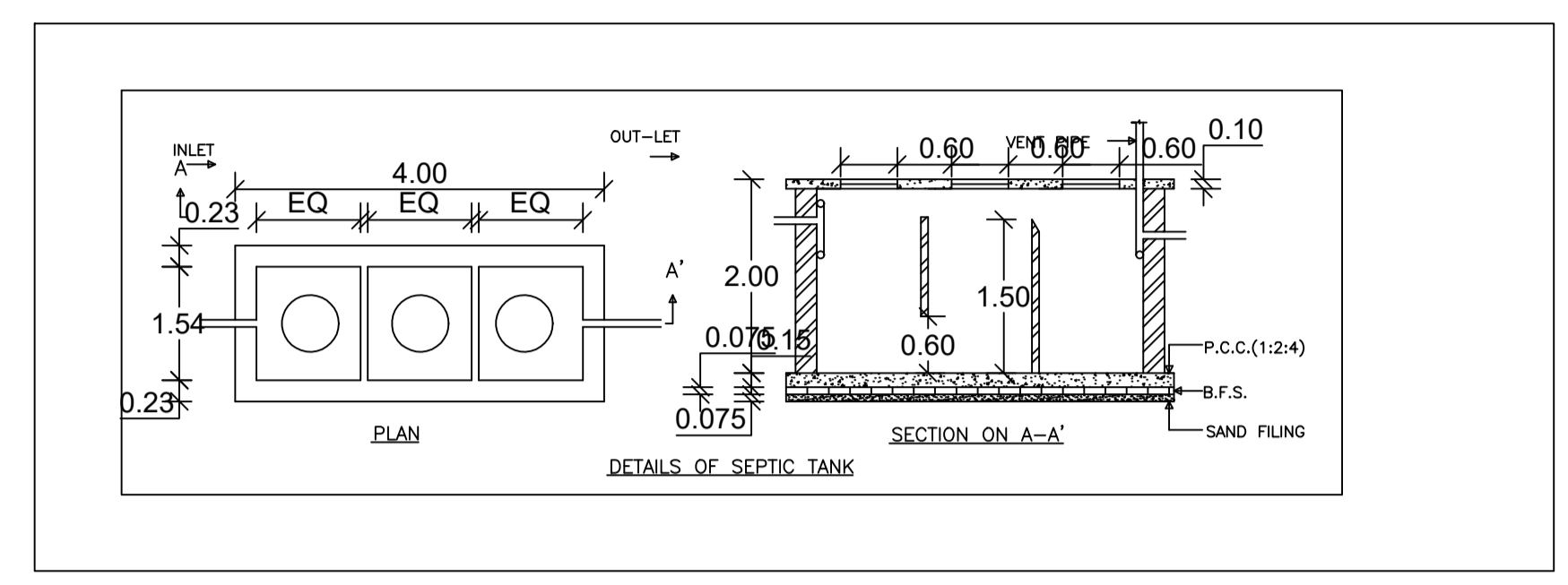
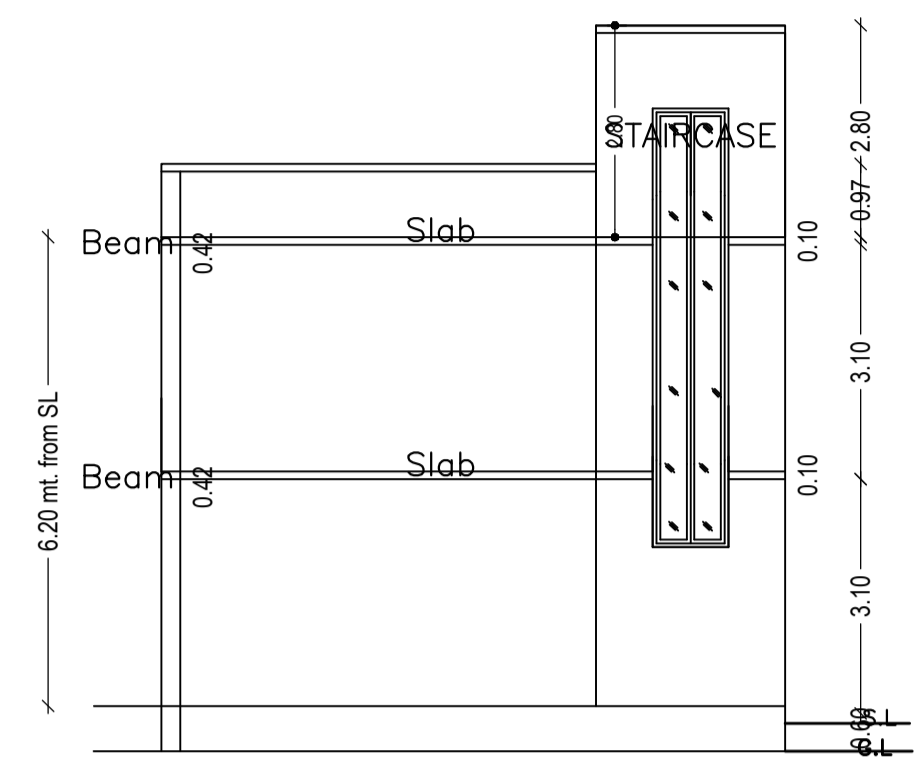
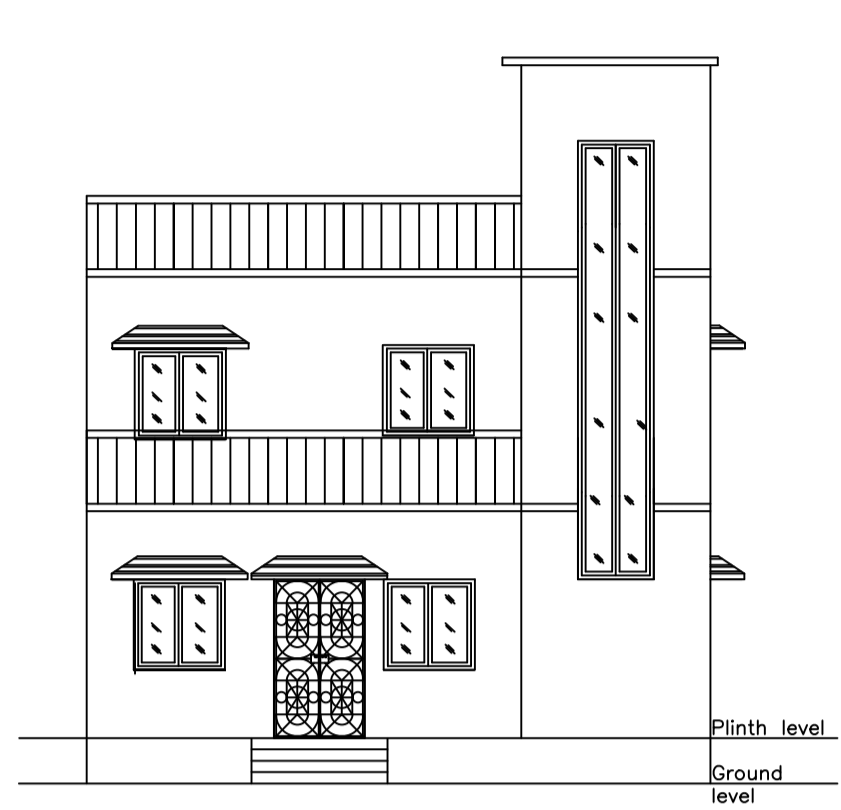

UnitBUA Table for Building :SS (BB)

FLOOR	Name	UnitBUA Type	UnitBUA Area	Carpet Area	No. of Rooms	No. of Tenement
GROUND FLOOR PLAN	SPLIT AA	FLAT	96.88	92.67	5	1
FIRST FLOOR PLAN	SPLIT AA	FLAT	0.00	0.00	5	0
Total:	-	-	96.88	92.67	10	1

COLOR INDEX

PLOT BOUNDARY	Black
ABUTTING ROAD	Red
PROPOSED CONSTRUCTION	Green
COMMON PLOT	Yellow
ROAD WIDENING AREA	Orange
EXISTING (To be retained)	Blue
EXISTING (To be demolished)	Light Blue

- ARCHITECTURAL SPECIFICATION:-
- DIMENSION:- All dimension are in mm. except otherwise stated.
 - FOUNDATION:- 1:1.5:3 cement concrete for footing over RCC mat of 1:4:8 mix.
 - SUPERSTRUCTURE:- 1:1.5:3 RCC column with brickwork with cement sand mortar (1:6) for 0.250M. thick wall & (1:4) for 0.125M. thick wall.
 - DAMP PROOF COURSE:- 40mm. thick CC (1:2:4) with suitable water proofing compound.
 - PLASTER:- 12mm. TO 20 mm. thick cement & sand mortar (1:4).
 - FLOORING:- 25 mm. thick IPS flooring over 100 mm. thick PCC and over 014M. thick RCC slab.
 - TOILET:- IWC & EWC with standard fittings.
 - DOOR:- G= 1.2M x 2.1M, D=1.05M x 2.1M, D1=0.975M x 2.1M, D2=0.9M x 2.1M, D3=0.75M x 2.1M
 - WINDOW:- W1=1.5M x 1.2M, W2=1.05M x 1.2M
 - VENTILATOT:- V = 0.6M x 0.45M

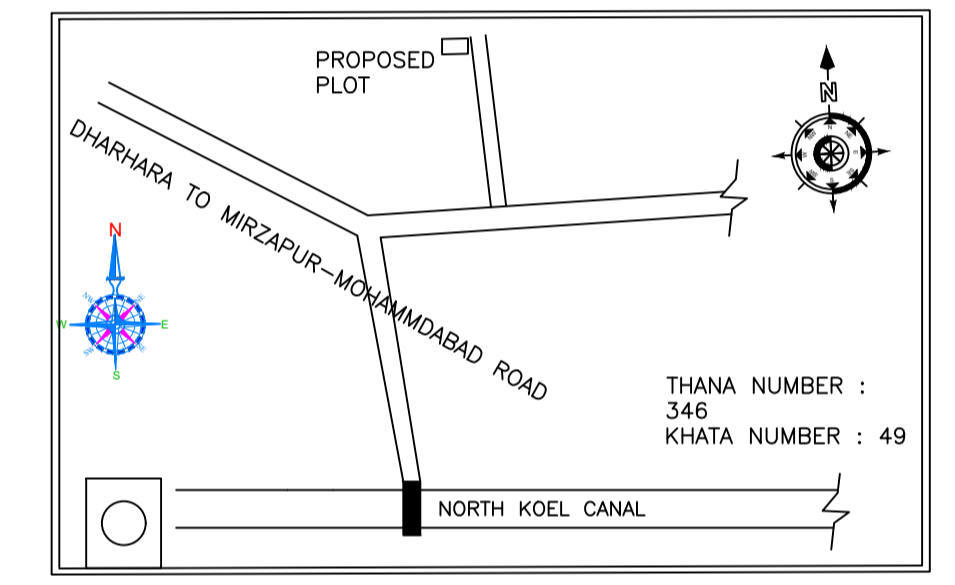
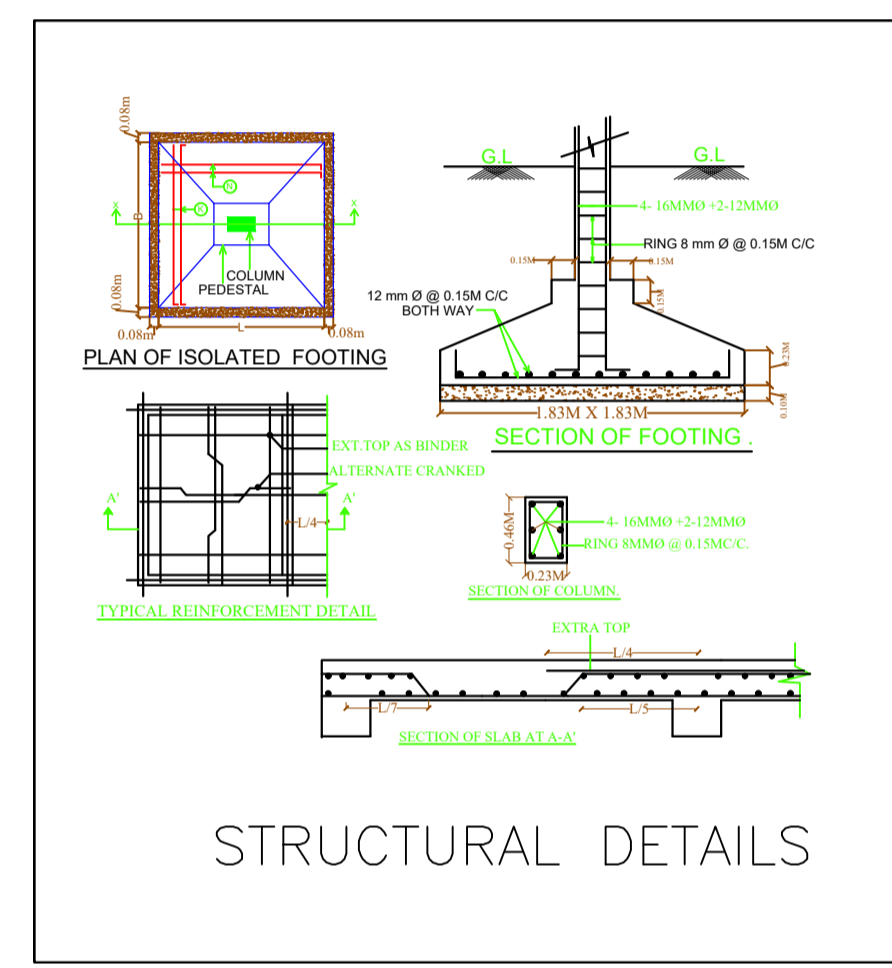

Building USE/SUBUSE Details

Building Name	Building Use	Building SubUse	Building Structure
SS (BB)	Residential	Bungalow/ Dwelling / Non Apartment	Non-Highrise

AREA STATEMENT		VERSION NO. : 1.0.65
Hussainabad Nagar Panchayat		VERSION DATE: 16/10/2020
PROJECT DETAIL:		
Region: JHARKHAND URBAN LOCAL BODIES	Plot Use: Residential	
District: PALAMU	Plot SubUse: Bungalow/ Dwelling / Non Apartment	
Authority: Hussainabad Nagar Panchayat	PlotNearby/Religious/Structure: NA	
Inward_No: HNPC/BP/0030/W11/2022	Plot/SubPlot No: 601	
Application Type: General Proposal	North: Plot No. - Ouddus Ansari	
Project Type: Building Permission	South: Plot No. - Niz Sellar	
Nature of Development Area: New	East: Road Width - 3.60 M Road	
Location of Development Area: Old Area	West: Plot No. - Munnai lal choudhary	
AREA DETAILS:		SQ.MT.
AREA OF PLOT (Minimum)	(A)	80.97
NET AREA OF PLOT (Gross Plot Area - Deduction from Gross Plot Area)	(A-Deductions)	80.97
Deduction for Balance Plot Area(from Gross Plot Area)		
Common Plot		6.89
Total		6.89
BALANCE AREA OF PLOT(Net Plot Area - Recreational/Amenity space)	(A-Deductions)	74.09
PLOT AREA FOR COVERAGE(Net Plot Area)	(A-Deductions)	80.97
Plot Area for FAR (Net Plot Area + Road/Widening Area)	(A-Deductions)	80.97
COVERAGE CHECK		
Permissible Coverage area (70.00 %)		56.68
Proposed Coverage Area (68.78 %)		55.69
Total Prop. Coverage Area (68.78 %)		55.69
Balance coverage area (1.22 %)		0.99
FAR CHECK		
Perm. FAR Area (1.500)		121.46
Total Perm. FAR area		121.46
Residential FAR		111.38
Proposed FAR Area		111.38
Total Proposed FAR Area		111.38
Consumed FAR (Factor)		1.38
Balance FAR Area		10.08
BUILT UP AREA CHECK		
Total Proposed BuiltUp Area		111.38
ARCHITECT (Regd)		MERAJ SARWER ANSARI
ENGINEER (Regd)		
SUPERVISOR (Regd)		
OWNER (Regd)		Nilu Devi
DEVELOPMENT AUTHORITY		LOCAL BODY

Buildingwise Floor FAR Details

Floor Name	Building Name		Total	
	Proposed Built Up Area (Sq.mt.)	Proposed FAR Area (Sq.mt.)	Total Proposed Built Up Area (Sq.mt.)	Total FAR Area (Sq.mt.)
Ground Floor	55.69	55.69	55.69	55.69
First Floor	55.69	55.69	55.69	55.69
Terrace Floor	0.00	0.00	0.00	0.00
Total:	111.38	111.38	111.38	111.38

Building :SS (BB)

Floor Name	Total Built Up Area (Sq.mt.)	Proposed FAR Area (Sq.mt.) Resi.	Total FAR Area (Sq.mt.)	Total Consumed Additional FAR Area (Sq.mt.)	Tnmt (No.)
Ground Floor	55.69	55.69	55.69	55.69	01
First Floor	55.69	55.69	55.69	55.69	00
Terrace Floor	0.00	0.00	0.00	0.00	00
Total	111.38	111.38	111.38	111.38	01
Total Number of Same Buildings	1				
Total:	111.38	111.38	111.38	111.38	01

SCHEDULE OF DOOR:

BUILDING NAME	NAME	LENGTH	HEIGHT	NOS
SS (BB)	D4	0.90	2.10	04
SS (BB)	D3	1.00	2.10	04
SS (BB)	D2	1.00	2.10	02

SCHEDULE OF WINDOW/VENTILATION:

BUILDING NAME	NAME	LENGTH	HEIGHT	NOS
SS (BB)	W2	1.00	1.20	02
SS (BB)	W1	1.20	1.20	10

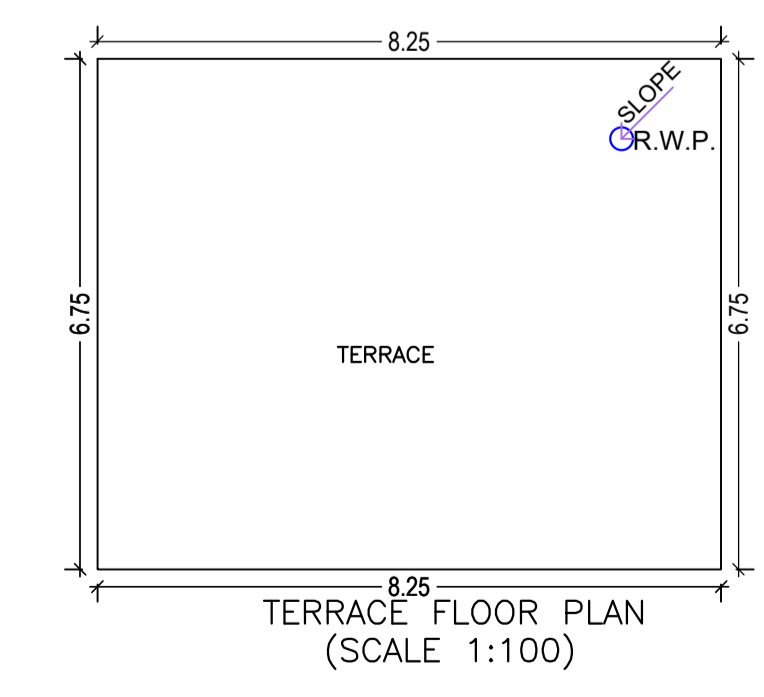
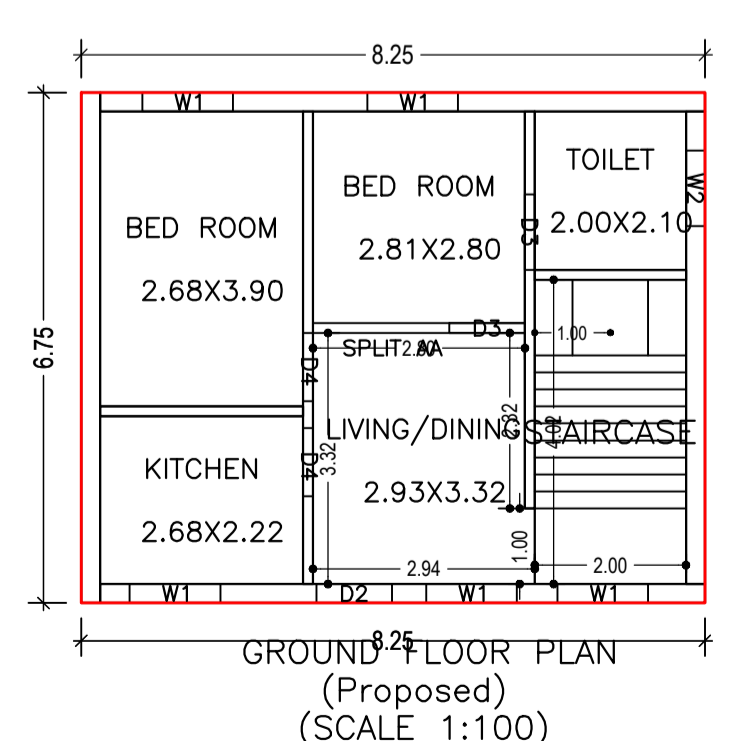
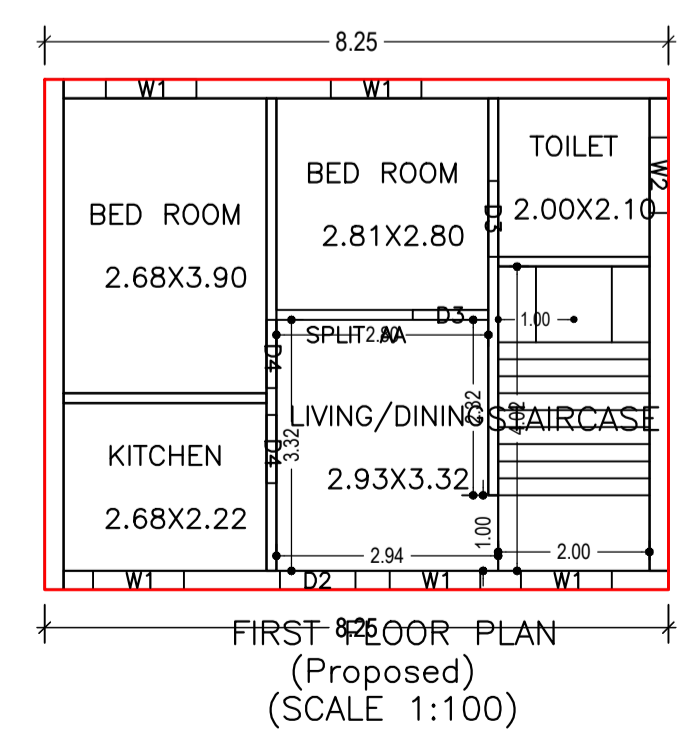
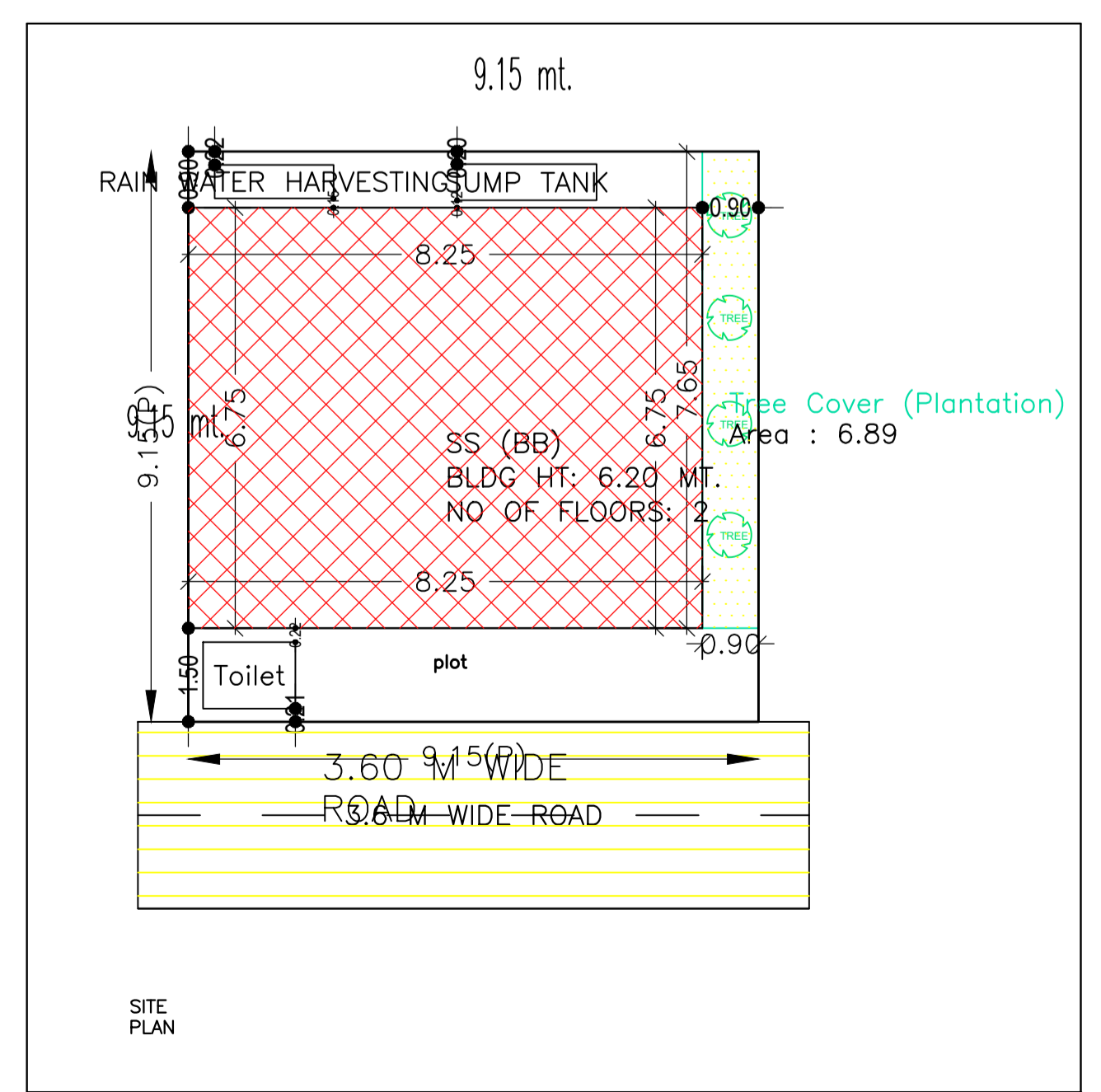

FAR & Tenement Details (Table 4c-1)

Building	No. of Same Bldg	Total Built Up Area (Sq.mt.)	Proposed FAR Area (Sq.mt.) Resi.	Total FAR Area (Sq.mt.)	Total Consumed Additional FAR Area (Sq.mt.)	Tnmt (No.)
SS (BB)	1	111.38	111.38	111.38	111.38	01
Grand Total:	1	111.38	111.38	111.38	111.38	01

LTP NAME AND SIGNATURE	STRUCTURAL ENG'S NAME AND SIGNATURE	BUILDER NAME AND SIGNATURE	DIGITAL SIGNATURE
MERAJ SARWER ANSARI HNPC/ENG/003/2021			