

SITE PLAN

FAR & Tenement Details (Table 4c-1)

Building	No. of Same Bldg	Total Built Up Area (Sq.mt.)	Proposed FAR Area (Sq.mt.) Resi.	Total FAR Area (Sq.mt.)	Total Consumed Additional FAR Area (Sq.mt.)	Tnmt (No.)
PREM PRAKASH SHAHI (A BUILDING)	1	93.56	93.56	93.56	93.56	01
Grand Total :	1	93.56	93.56	93.56	93.56	01

Proposal Basic Information

Proposal File No.	HNPC/BP/0064/W02/2023
Owner Name	PREM PRAKASH SHAHI
Khata No	58
Plot No	608
Village Name	Main Road Japla
Use	Residential
SubUse	Bungalow/ Dwelling / Non Apartment

AREA STATEMENT Hussainabad Nagar Panchayat	VERSION NO. : 1.0.66 VERSION DATE: 16/10/2020
PROJECT DETAIL:	
Region: JHARKHAND URBAN LOCAL BODIES	Plot Use: Residential
District: PALAMU	Plot SubUse: Bungalow/ Dwelling / Non Apartment
Authority: Hussainabad Nagar Panchayat	PlotNearbyReligiousStructure: NA
Inward No: HNPC/BP/0064/W02/2023	PlotSubPlot No: 608
Application Type: General Proposal	North: -
Project Type: Building Permission	South: -
Nature of Development: New	East: -
Location of Development Area: Old Area	West: -
AREA DETAILS:	
AREA OF PLOT (Minimum)	(A) 77.67
NET AREA OF PLOT(Gross Plot Area - Deduction from Gross Plot area)	(A-Deductions) 77.67
Deduction for Balance Plot Area(from Gross Plot Area)	
Common Plot	15.25
Total	15.25
BALANCE AREA OF PLOT(Net Plot Area - Recreational/Amenity space)	(A-Deductions) 62.42
PLOT AREA FOR COVERAGE(Net Plot Area)	(A-Deductions) 77.67
Plot Area for FAR (Net Plot Area + RoadWidening Area)	(A-Deductions) 77.67
COVERAGE CHECK	
Permissible Coverage area (70.00 %)	54.37
Proposed Coverage Area (60.23 %)	46.78
Total Prop. Coverage Area (60.23 %)	46.78
Balance coverage area (9.77 %)	7.59
FAR CHECK	
Perm. FAR Area (1.500)	116.50
Total Perm. FAR area	116.50
Residential FAR	93.56
Proposed FAR Area	93.56
Total Proposed FAR Area	93.56
Consumed FAR (Factor)	1.20
Balance FAR Area	22.94
BUILT UP AREA CHECK	
Total Proposed BuiltUp Area	93.56
ARCHITECT (Regd)	Anuj Kumar Paswan
ENGINEER (Regd)	
SUPERVISOR (Regd)	
OWNER (Regd)	PREM PRAKASH SHAHI
DEVELOPMENT AUTHORITY	
	LOCAL BODY

COLOR INDEX	
PLOT BOUNDARY	Black
ABUTTING ROAD	Green
PROPOSED CONSTRUCTION	Red
COMMON PLOT	Yellow
ROAD WIDENING AREA	Orange
EXISTING (To be retained)	Blue
EXISTING (To be demolished)	Light Blue

Buildingwise Floor FAR Details

Floor Name	Building Name		Total	
	Proposed Built Up Area (Sq.mt.)	Proposed FAR Area (Sq.mt.)	Total Proposed Built Up Area (Sq.mt.)	Total FAR Area (Sq.mt.)
Ground Floor	46.78	46.78	46.78	46.78
First Floor	46.78	46.78	46.78	46.78
Terrace Floor	0.00	0.00	0.00	0.00
Total :	93.56	93.56	93.56	93.56

Building USE/SUBUSE Details

Building Name	Building Use	Building SubUse	Building Structure
PREM PRAKASH SHAHI (A BUILDING)	Residential	Bungalow/ Dwelling / Non Apartment	Non-Highrise

LTP NAME AND SIGNATURE	STRUCTURAL ENG'S NAME AND SIGNATURE	BUILDER NAME AND SIGNATURE	DIGITAL SIGNATURE
Anuj Kumar Paswan HNPC/ENG/0002/2022			

Proposal Basic Information	
Proposal File No.	HNPC/BP/0064/W02/2023
Owner Name	PREM PRAKASH SHAHI
Khata No	58
Plot No	608
Village Name	Main Road Japla
Use	Residential
SubUse	Bungalow/ Dwelling / Non Apartment

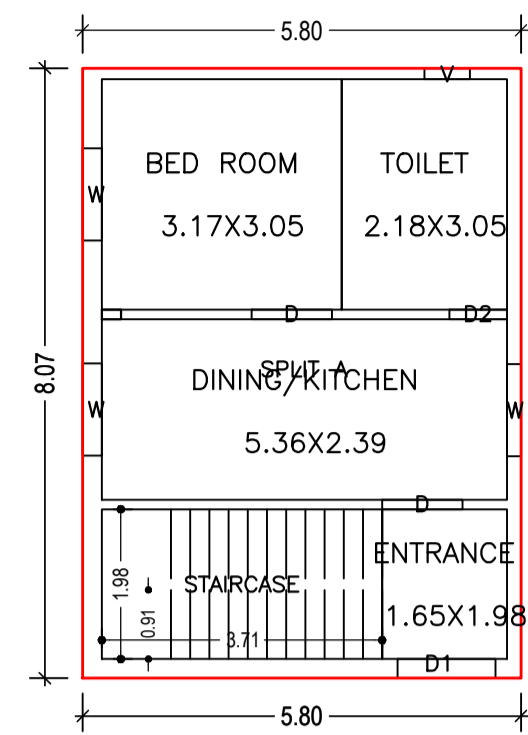

GROUND FLOOR PLAN (Proposed) (SCALE 1:100)

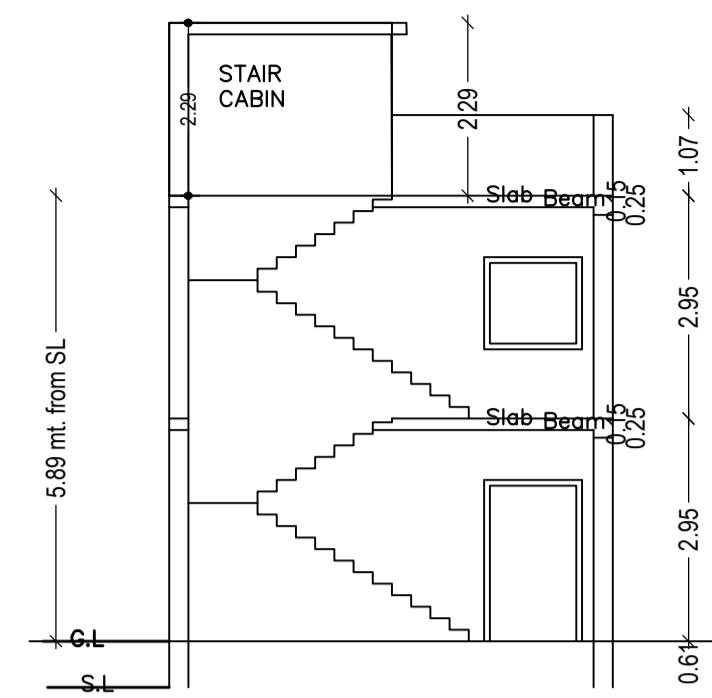

SECTION X-X

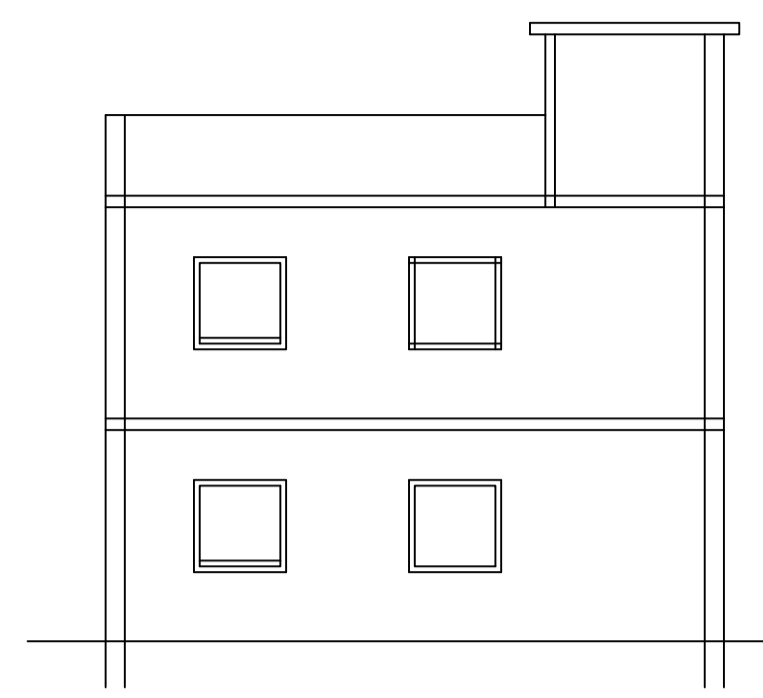

SECTION Y-Y

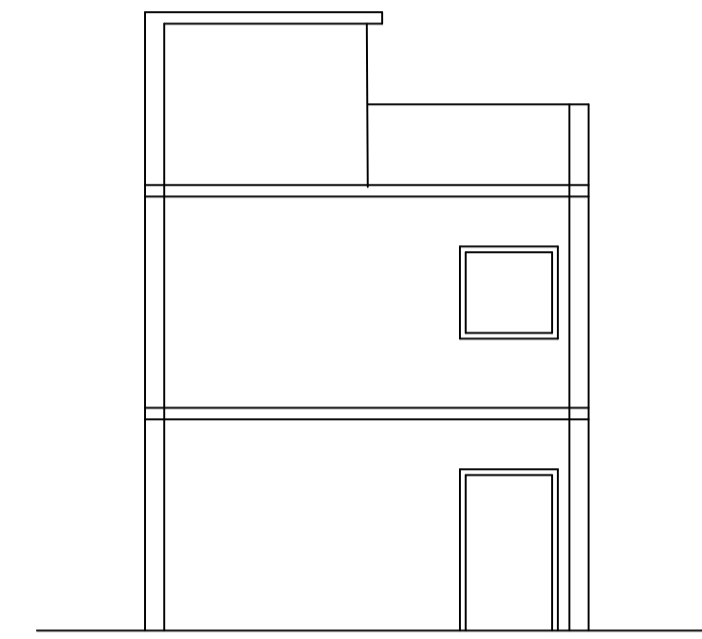

ELEVATION FRONT

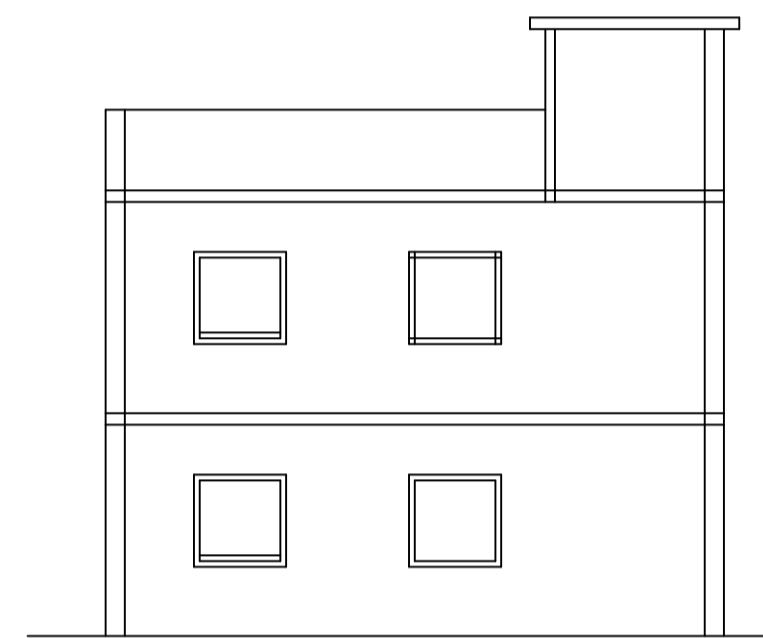

ELEVATION SIDE

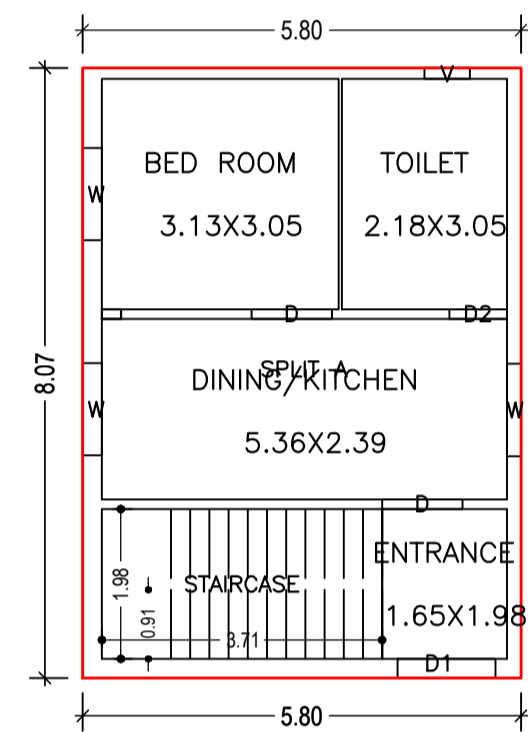

FIRST FLOOR PLAN (Proposed) (SCALE 1:100)

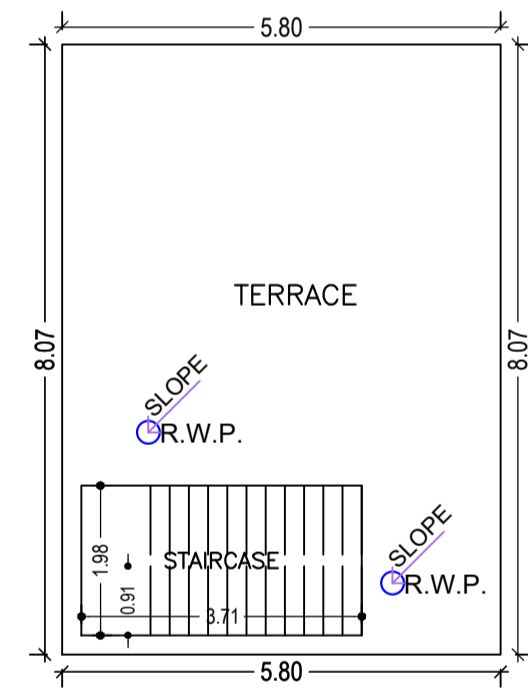

TERRACE FLOOR PLAN (SCALE 1:100)

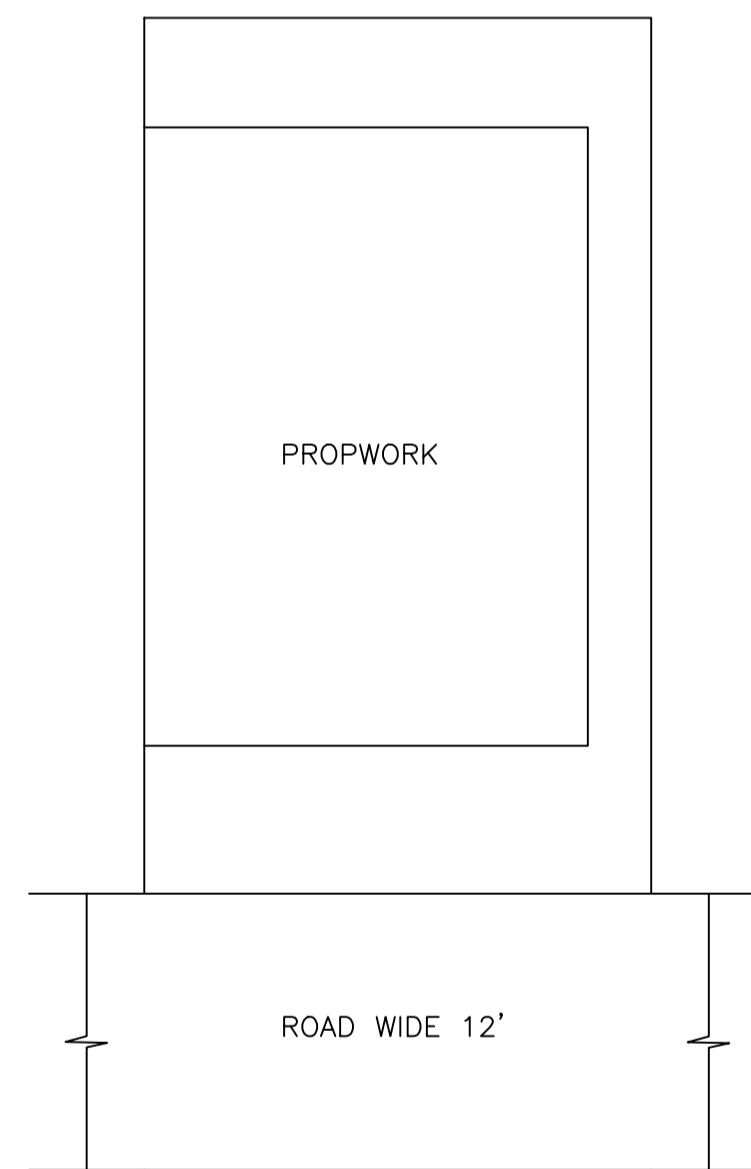

PROPWORK

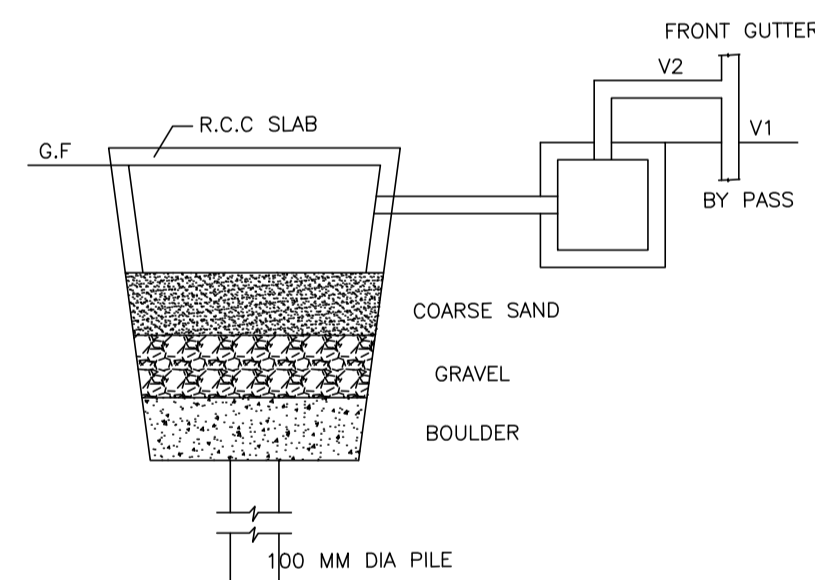

SECTION A-A

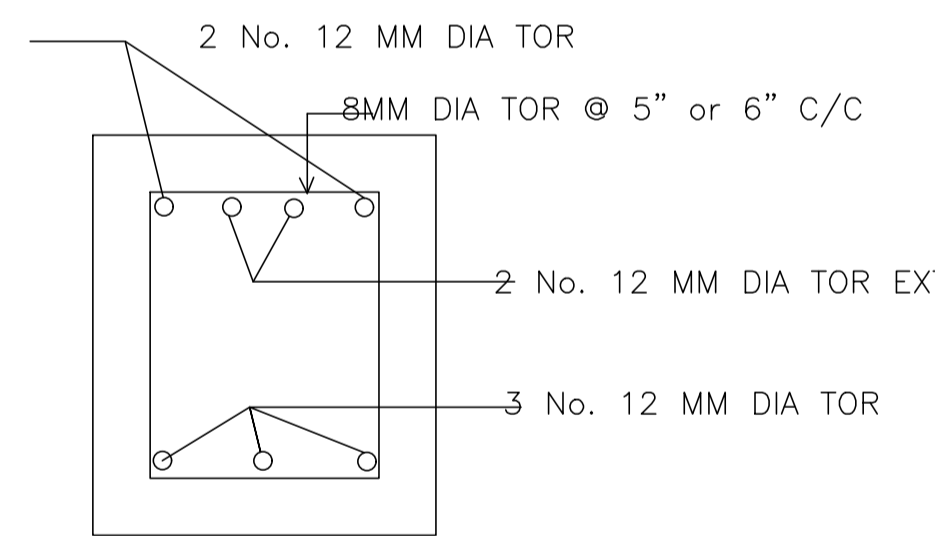

DET. OF RECHARGEABLE BORE WELL

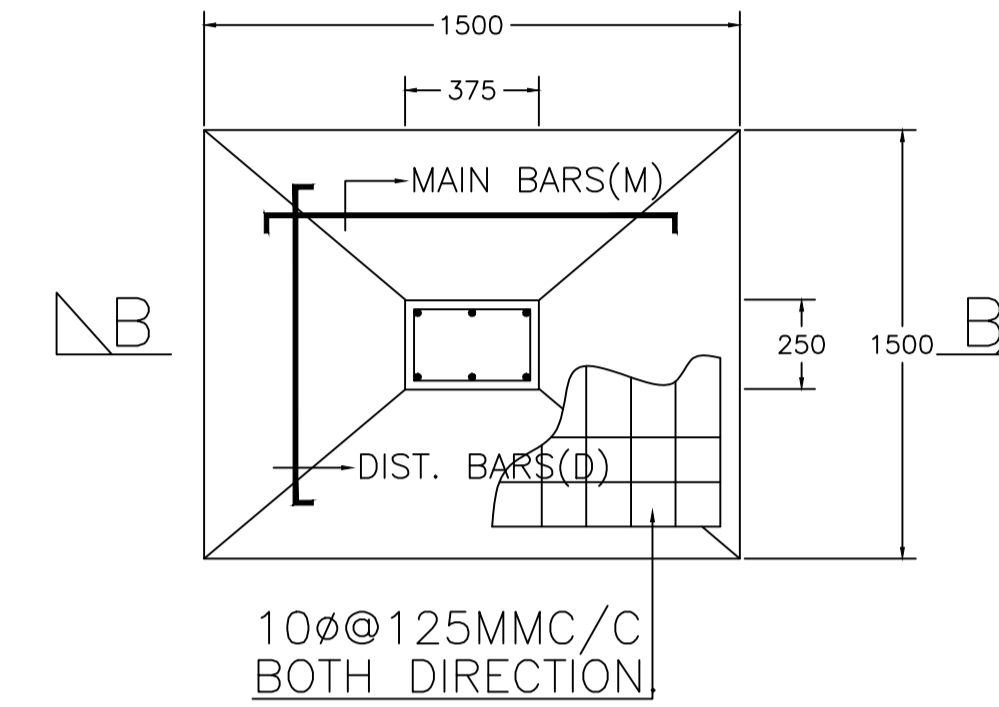

FOUNDATION PLAN OF CLOUMN

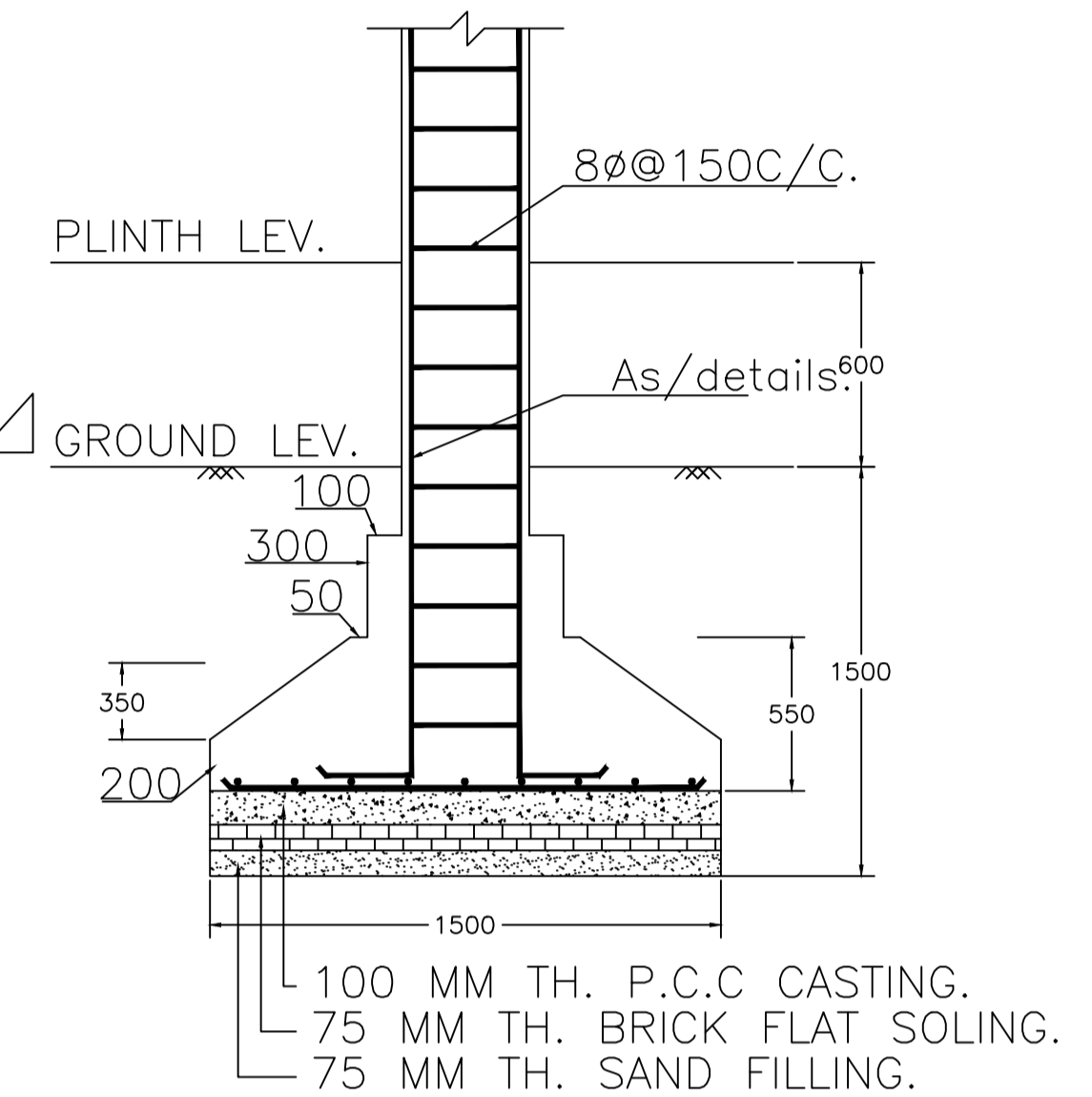

SECTION:-(B-B)

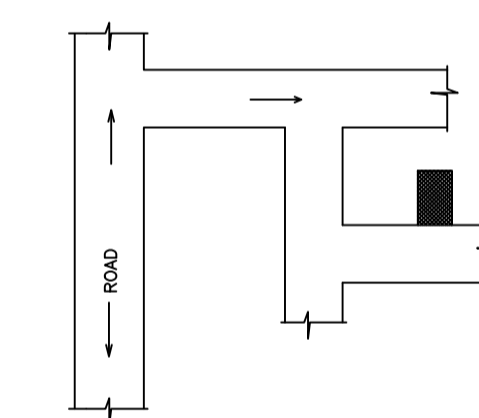

LOCATION MAP (SCALE: (N.T.S))

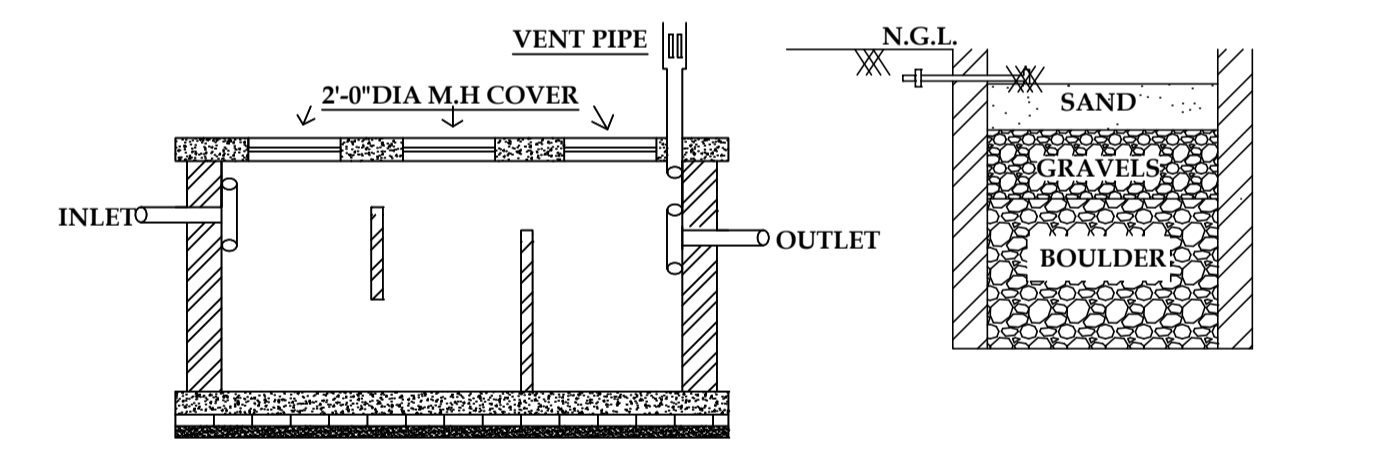

SECTION AT C-C

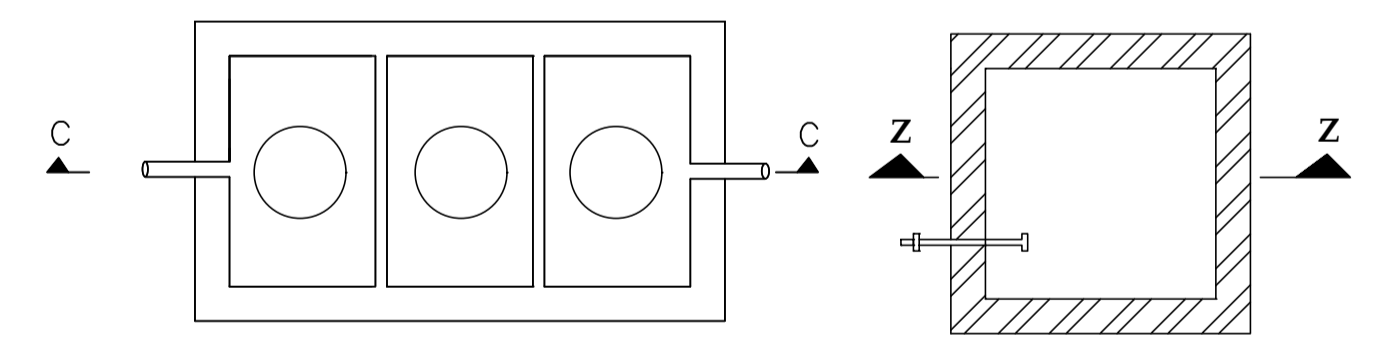

SECTION AT Z-Z

PLAN DET. OF SEPTIC TANK (SCALE = 1:48)

R.W.H PLAN (SCALE - 1 : 48)

SCHEDULE OF DOOR:

BUILDING NAME	NAME	LENGTH	HEIGHT	NOS
PREM PRAKASH SHAHI (A BUILDING)	D2	0.76	2.10	02
PREM PRAKASH SHAHI (A BUILDING)	D	1.06	2.10	04
PREM PRAKASH SHAHI (A BUILDING)	D1	1.30	2.10	02

SCHEDULE OF WINDOW/VENTILATION:

BUILDING NAME	NAME	LENGTH	HEIGHT	NOS
PREM PRAKASH SHAHI (A BUILDING)	V	0.60	1.20	02
PREM PRAKASH SHAHI (A BUILDING)	W	1.22	1.20	06

Building :PREM PRAKASH SHAHI (A BUILDING)

Floor Name	Total Built Up Area (Sq.mt.)	Proposed FAR Area (Sq.mt.) Resi.	Total FAR Area (Sq.mt.)	Total Consumed Additional FAR Area (Sq.mt.)	Tnmt (No.)
Ground Floor	46.78	46.78	46.78	46.78	01
First Floor	46.78	46.78	46.78	46.78	00
Terrace Floor	0.00	0.00	0.00	0.00	00
Total :	93.56	93.56	93.56	93.56	01
Total Number of Same Buildings	1				
Total :	93.56	93.56	93.56	93.56	01

UnitBUA Table for Building :PREM PRAKASH SHAHI (A BUILDING)

FLOOR	Name	UnitBUA Type	UnitBUA Area	Carpet Area	No. of Rooms	No. of Tenement
GROUND FLOOR PLAN	SPLIT A	FLAT	66.59	66.52	4	1
FIRST FLOOR PLAN	SPLIT A	FLAT	0.00	0.00	4	0
Total:	-	-	66.59	66.52	8	1

LTP NAME AND SIGNATURE	STRUCTURAL ENG'S NAME AND SIGNATURE	BUILDER NAME AND SIGNATURE	DIGITAL SIGNATURE
Anuj Kumar Paswan HNPC/ENG/0002/2022			