

STRUCTURAL DETAILS

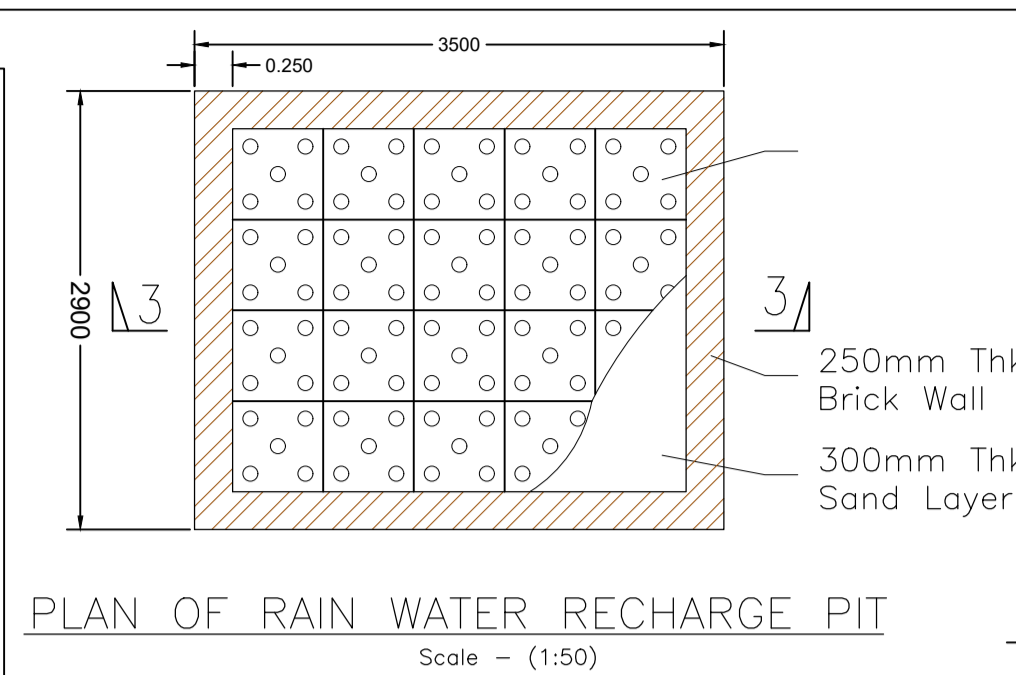

PLAN OF RAIN WATER RECHARGE PIT
Scale - (1:50)

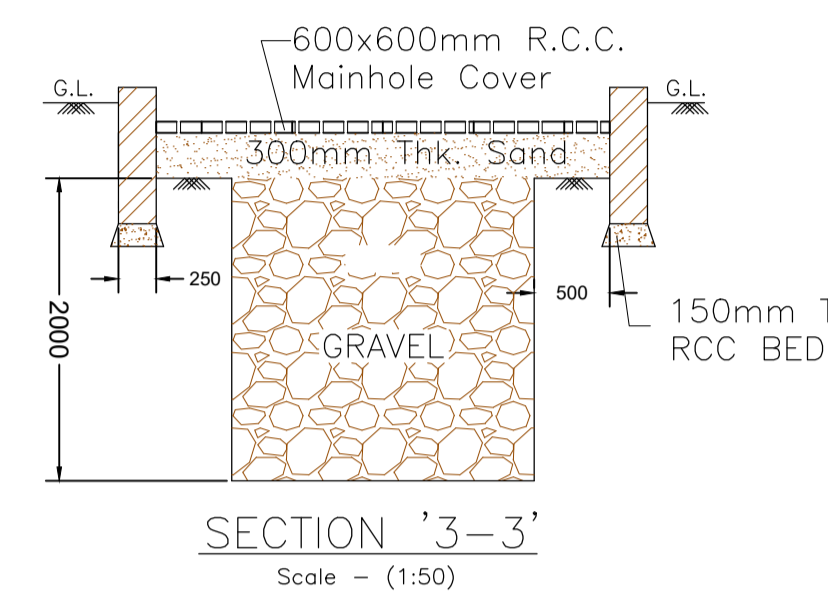

SECTION '3-3'
Scale - (1:50)

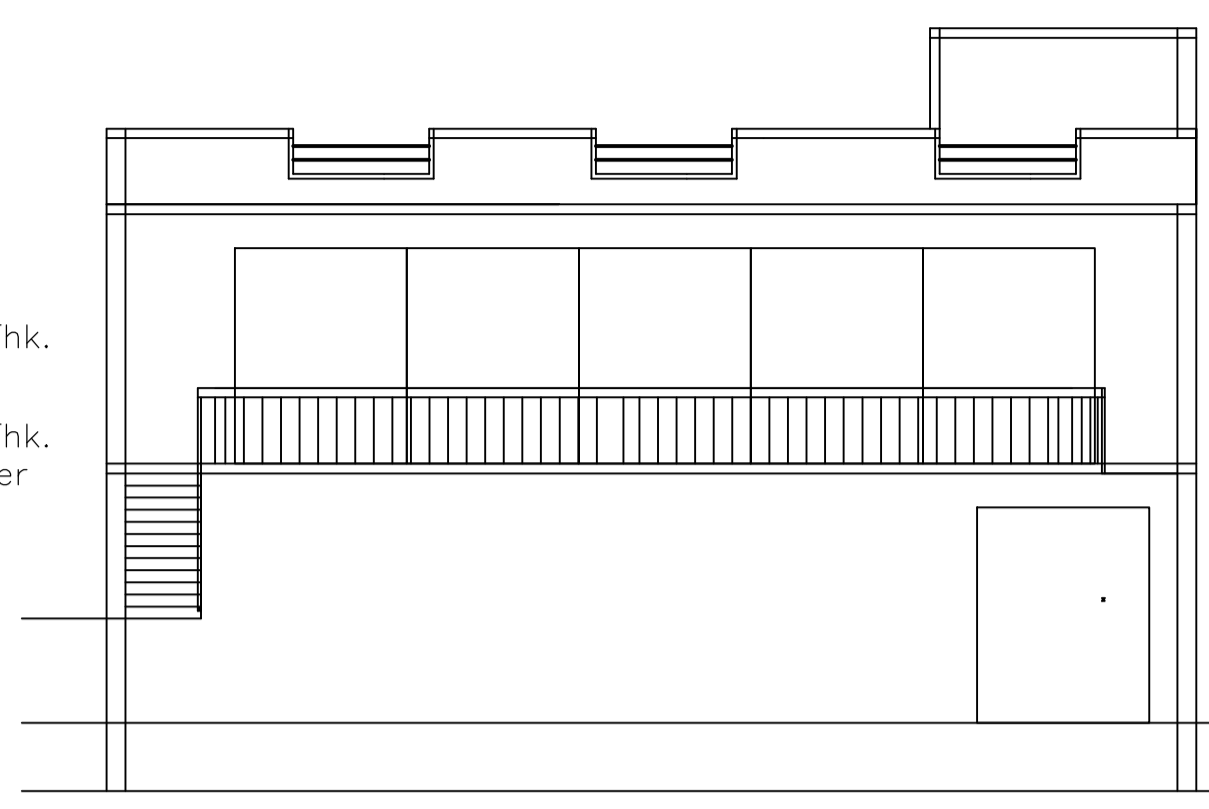

- ARCHITECTURAL SPECIFICATION:-**
- DIMENSION:- All dimension are in mm, except otherwise stated.
 - FOUNDATION:- 1:1.5:3 cement concrete for footing over RCC mat of 1:4:8 mix.
 - SUPERSTRUCTURE:-1:1.5:3 RCC column with brickwork with cement sand mortar (1:6) for 0.250M. thick wall & (1:4) for 0.125M. thick wall.
 - DAMP PROOF COURSE:- 40mm. thick CC (1:2:4) with suitable water proofing compound.
 - PLASTER:- 12mm. TO 20 mm. thick cement & sand mortar (1:6).
 - FLOORING:-25 mm. thick IPS flooring over 100 mm. thick PCC and over 0114M. thick RCC slab.
 - TOILET:- IWC & EWC with standard fittings.
 - DOOR:- G= 1.2M x 2.1M, D=0.9M x 2.1M, D1=0.975M x 2.1M, D2=0.9M x 2.1M, D3=0.75M x 2.1M.
 - WINDOW-W1=1.5M x 1.2M, W2=1.05M x 1.2M
 - VENTILATOT:- V = 0.6M x 0.45M

Building :AA (BB)

Floor Name	Total Built Up Area (Sq.mt.)	Deductions (Area in Sq.mt.)	Proposed FAR Area (Sq.mt.)	Add Area In FAR (Sq.mt.)	Total FAR Area (Sq.mt.)	Total Consumed Additional FAR Area (Sq.mt.)	Tnmt (No.)
Ground Floor	101.54	88.71	0.00	12.83	12.83	12.83	00
First Floor	101.53	0.00	101.53	0.00	101.53	101.53	01
Terrace Floor	0.00	0.00	0.00	0.00	0.00	0.00	00
Total :	203.07	88.71	101.53	12.83	114.36	114.36	01
Total Number of Same Buildings :	1						
Total :	203.07	88.71	101.53	12.83	114.36	114.36	01

Buildingwise Floor FAR Details

Floor Name	Building Name		Total	
	Proposed Built Up Area (Sq.mt.)	Proposed FAR Area (Sq.mt.)	Total Proposed Built Up Area (Sq.mt.)	Total FAR Area (Sq.mt.)
Ground Floor	101.54	12.83	101.54	12.83
First Floor	101.53	101.53	101.53	101.53
Terrace Floor	0.00	0.00	0.00	0.00
Total :	203.07	114.36	203.07	114.36

Required Parking (Table 7a)

Building Name	Type	SubUse	Area (Sq.mt.)	Reqd. Units	Car	Visitors Car	TwoWheeler
AA (BB)	Commercial	Commercial Bldg	>0	200	88.71	1	1
			>0	200	88.71	-	-
Total :						1	3
						0	1
						1	5

Parking Check (Table 7b)

Vehicle Type	Reqd.		Prop.	
	No.	Area	No.	Area
Car	-	-	3	37.50
Total Car	1	12.50	3	37.50
Visitor's Car Parking	-	-	1	12.50
Total Visitor Parking	-	-	1	12.50
TwoWheeler	-	-	5	11.11
Total TwoWheeler	1	2.00	5	11.11
Other Parking	-	-	-	63.71
Total		14.50		135.93

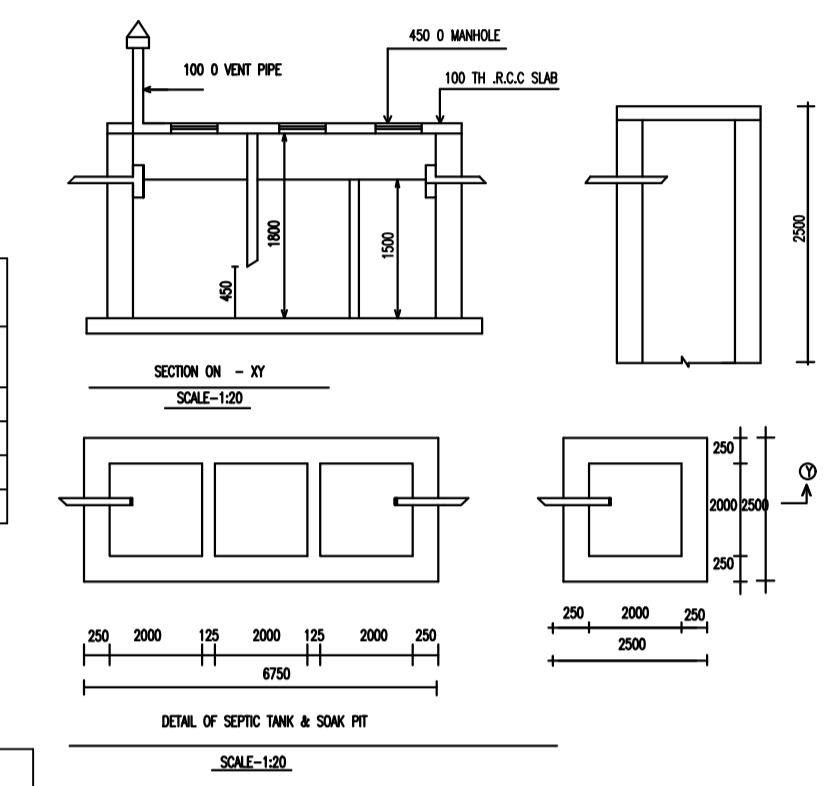

DETAILS OF WATER HARVESTING

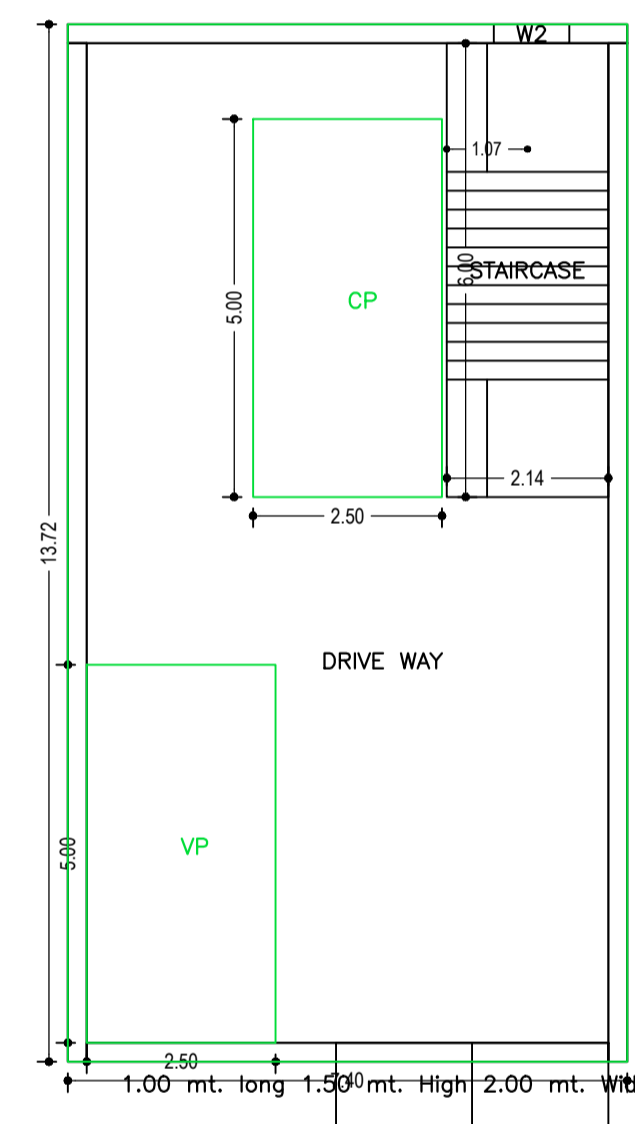

GROUND FLOOR PLAN (SCALE 1:100)

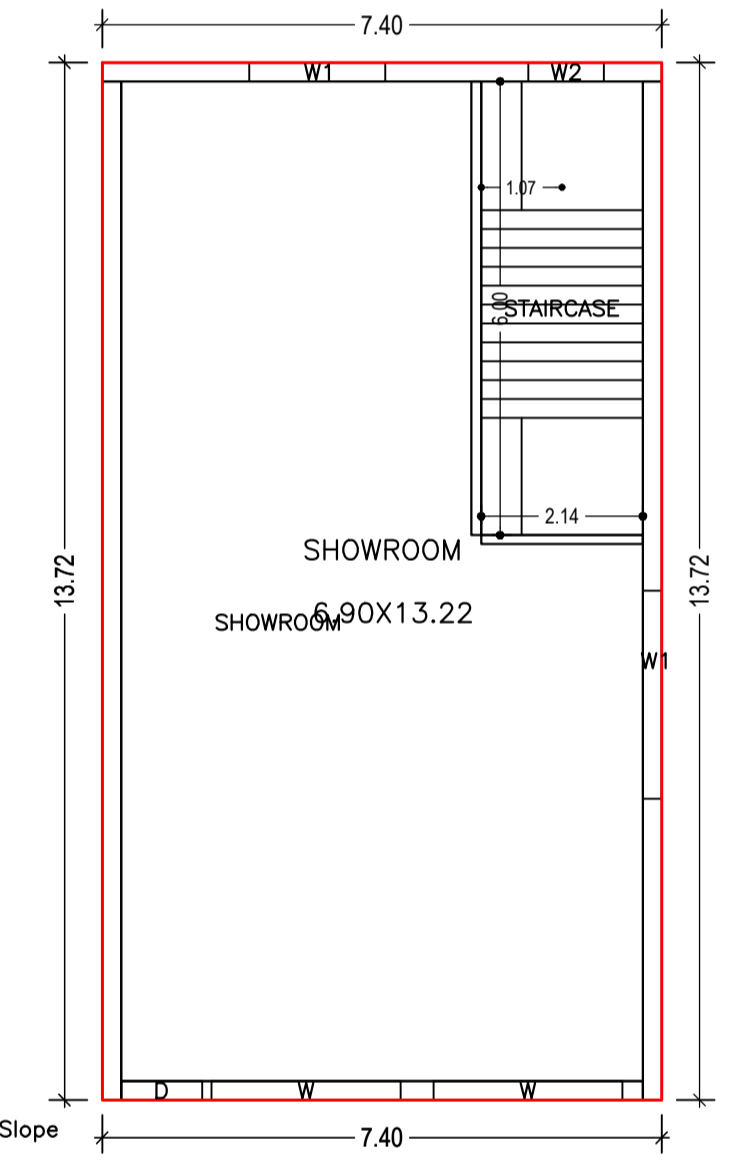

FIRST FLOOR PLAN (Proposed) (SCALE 1:100)

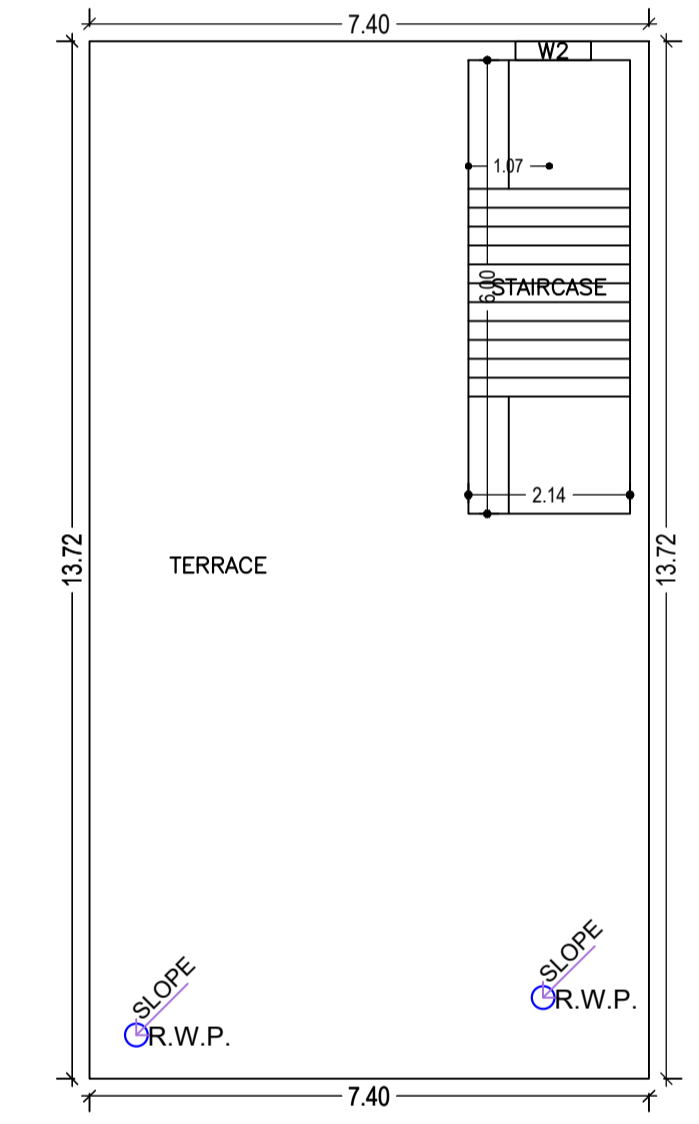

TERRACE FLOOR PLAN (SCALE 1:100)

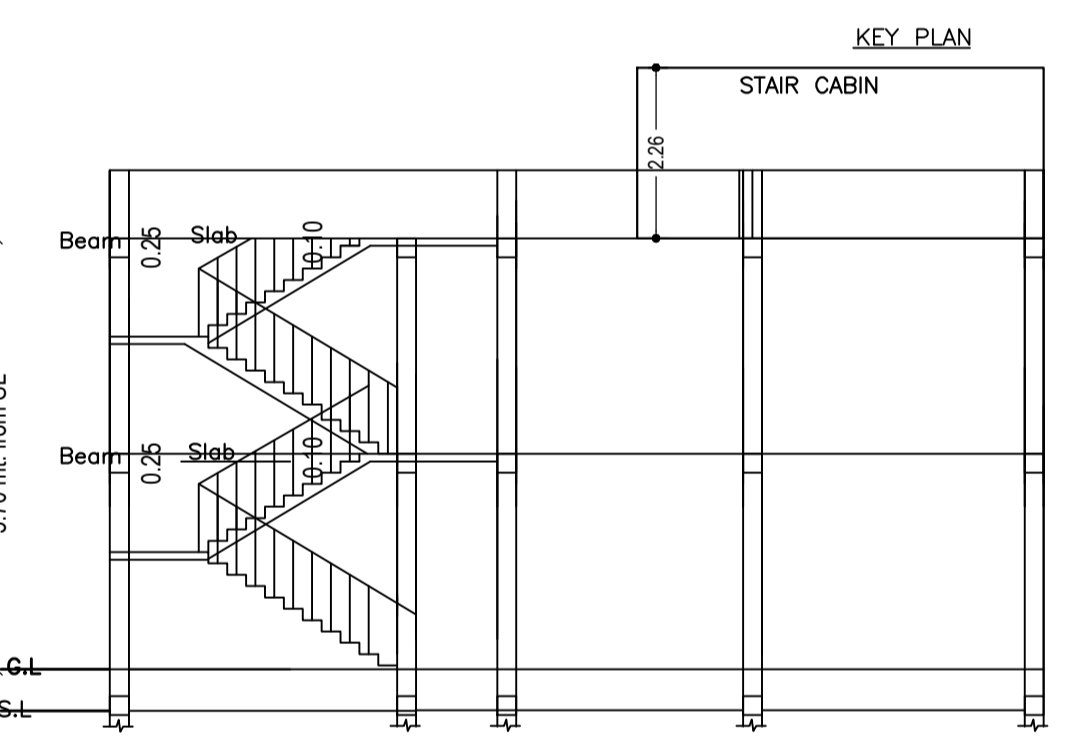

KEY PLAN

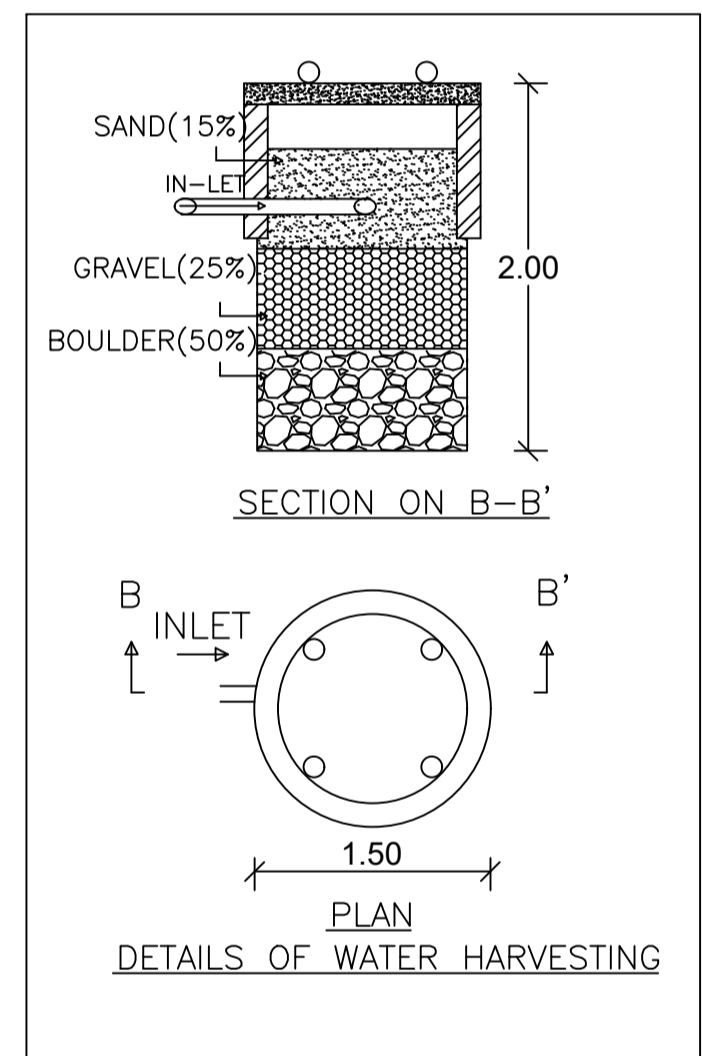

SECTION ON B-B'

PLAN DETAILS OF WATER HARVESTING

AREA STATEMENT
Hussainabad Nagar Panchayat

VERSION NO: 1.0.65
VERSION DATE: 16/10/2020

PROJECT DETAIL:
Region: JHARKHAND URBAN LOCAL BODIES
District: PALAMU
Authority: Hussainabad Nagar Panchayat
Inward No: HNPC/BP/0034/W07/2023
Application Type: General Proposal
Project Type: Building Permission
Nature of Development: New
Location of Development Area: Old Area

Plot Use: Commercial
Plot SubUse: Showroom
Plot/SubPlot No: 118
Plot/Nearby/Religious Structure: NA
North: Plot No. - Jagdish Vishwakarma
South: Plot No. - Jagnarayan vishwakarma
East: Road Width - 7.50 M Wide Road
West: Plot No. - Pond Bandh

AREA DETAILS:
AREA OF PLOT (Minimum) (A) 613.21
NET AREA OF PLOT (Gross Plot Area - Deduction from Gross Plot area) (A-Deductions) 613.21
Deduction for Balance Plot Area (from Gross Plot Area)
Common Plot 43.03
Total 43.03
BALANCE AREA OF PLOT (Net Plot Area - Recreational/Amenity space) (A-Deductions) 570.18
PLOT AREA FOR COVERAGE (Net Plot Area) (A-Deductions) 613.21
Plot Area for FAR (Net Plot Area + Road Widening Area) (A-Deductions) 613.21

COVERAGE CHECK
Permissible Coverage area (50.00 %) 306.61
Proposed Coverage Area (16.56 %) 101.53
Total Prop. Coverage Area (16.56 %) 101.53
Balance coverage area (33.44 %) 205.08

FAR CHECK
Perm. FAR Area (2.00) 1226.42
Total Perm. FAR area 1226.42
Commercial FAR 101.53
Proposed FAR Area 114.36
Total Proposed FAR Area 114.36
Consumed FAR (Factor) 0.19
Balance FAR Area 1112.06

BUILT UP AREA CHECK
Total Proposed BuiltUp Area 203.07

ARCHITECT (Regd) MERAJ SARWER ANSARI
ENGINEER (Regd)
SUPERVISOR (Regd)
OWNER (Regd) Rajeshwar Vishwakarma

DEVELOPMENT AUTHORITY LOCAL BODY

SCHEDULE OF DOOR:

BUILDING NAME	NAME	LENGTH	HEIGHT	NOS
AA (BB)	D	1.07	2.13	01

SCHEDULE OF WINDOW/VENTILATION:

BUILDING NAME	NAME	LENGTH	HEIGHT	NOS
AA (BB)	W2	1.00	2.70	03
AA (BB)	W1	1.80	2.70	01
AA (BB)	W	2.50	2.50	02
AA (BB)	W1	2.75	2.70	01

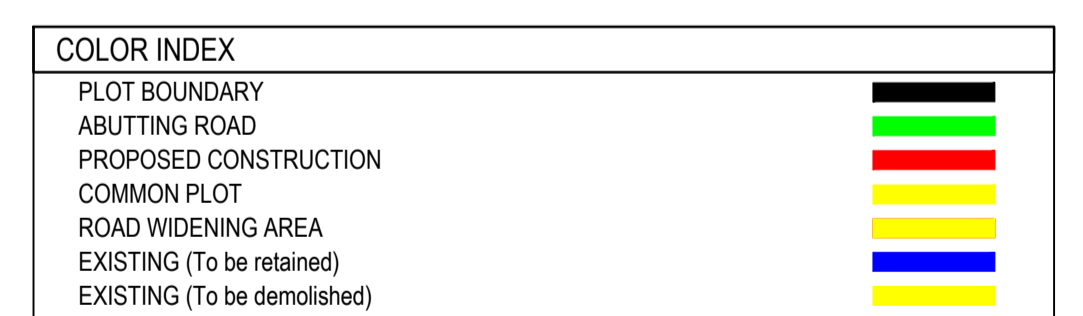

FAR & Tenement Details (Table 4c-1)

Building	No. of Same Bldg	Total Built Up Area (Sq.mt.)	Deductions (Area in Sq.mt.)	Proposed FAR Area (Sq.mt.)	Add Area In FAR (Sq.mt.)	Total FAR Area (Sq.mt.)	Total Consumed Additional FAR Area (Sq.mt.)	Tnmt (No.)
AA (BB)	1	203.07	88.71	101.53	12.83	114.36	114.36	01
Grand Total :	1	203.07	88.71	101.53	12.83	114.36	114.36	01

Building USE/SUBUSE Details

Building Name	Building Use	Building SubUse	Building Structure
AA (BB)	Commercial	Commercial Bldg	Non-Highrise

UnitBUA Table for Building :AA (BB)

FLOOR	Name	UnitBUA Type	UnitBUA Area	Carpet Area	No. of Rooms	No. of Tenement
FIRST FLOOR PLAN	SHOWROOM	SHOP	91.22	90.19	1	1
Total:			91.22	90.19	1	1

LTP NAME AND SIGNATURE	STRUCTURAL ENG'S NAME AND SIGNATURE	BUILDER NAME AND SIGNATURE	DIGITAL SIGNATURE
MERAJ SARWER ANSARI HNPC/ENG/0003/2021			