

Building :A (AKHILESH KUMAR)

Floor Name	Total Built Up Area (Sq.mt.)	Deductions (Area in Sq.mt.)			Proposed FAR Area (Sq.mt.)	Total FAR Area (Sq.mt.)	Total Consumed Additional FAR Area (Sq.mt.)	Trmt (No.)
		Parking	Resi.	Commercial				
Basement Floor	106.08	106.08	0.00	0.00	0.00	0.00	00	
First Floor	106.08	0.00	0.00	106.08	106.08	106.08	01	
Second Floor	106.08	0.00	106.08	0.00	106.08	106.08	01	
Third Floor	106.08	0.00	106.08	0.00	106.08	106.08	01	
Terrace Floor	0.00	0.00	0.00	0.00	0.00	0.00	00	
Total :	424.32	106.08	212.16	106.08	318.24	318.24	03	
Total Number of Same Buildings	1							
Total :	424.32	106.08	212.16	106.08	318.24	318.24	03	

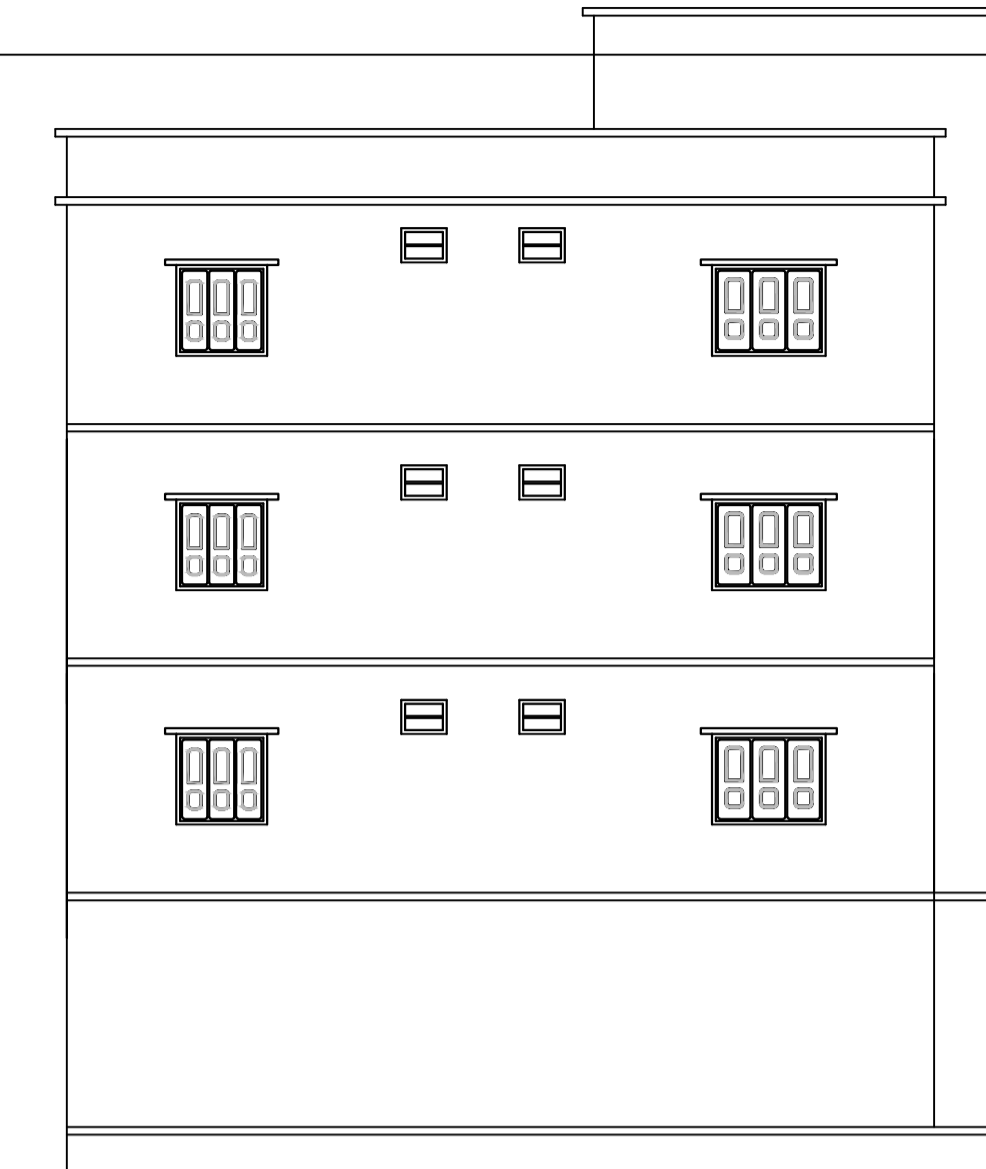
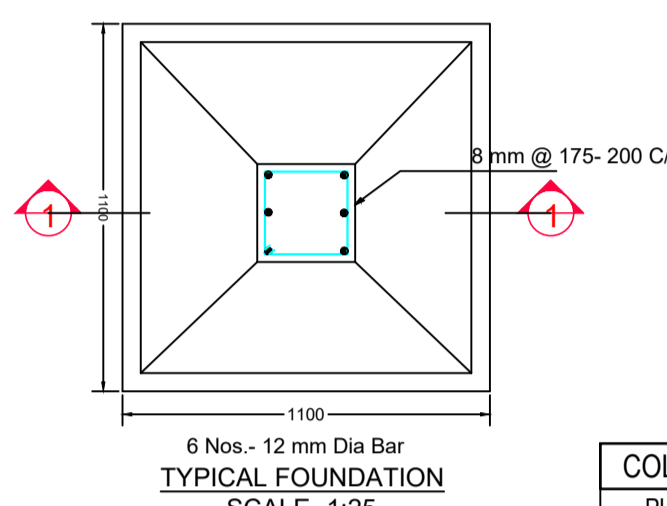
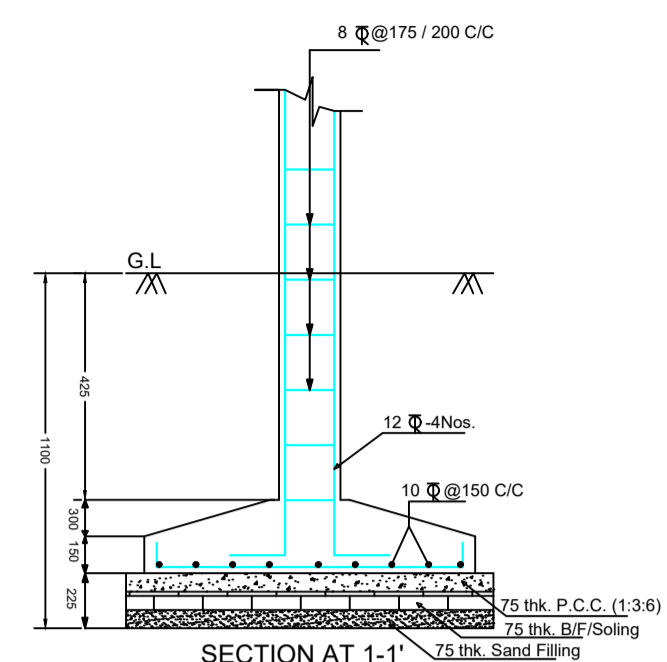

Proposal Basic Information

Proposal File No.	HNPC/BP/0035/W02/2023
Owner Name	Akhilesh Kumar Singh
Khata No	52
Plot No	604.692
Village Name	Main Road Jalpa
Use	Mixed
SubUse	Resi+Comm

SCHEDULE OF DOOR:

BUILDING NAME	NAME	LENGTH	HEIGHT	NOS
A (AKHILESH KUMAR)	D2	0.68	2.13	01
A (AKHILESH KUMAR)	D3	0.75	2.13	03
A (AKHILESH KUMAR)	D1	0.95	2.13	02
A (AKHILESH KUMAR)	D	1.07	2.13	03

SCHEDULE OF WINDOW/VENTILATION:

BUILDING NAME	NAME	LENGTH	HEIGHT	NOS
A (AKHILESH KUMAR)	V	0.60	2.00	02
A (AKHILESH KUMAR)	W2	1.00	2.70	11
A (AKHILESH KUMAR)	W1	1.80	2.70	06
A (AKHILESH KUMAR)	W	2.50	2.50	02
A (AKHILESH KUMAR)	W1	2.61	2.70	01
A (AKHILESH KUMAR)	W1	2.75	2.70	01

UnitBUA Table for Building :A (AKHILESH KUMAR)

FLOOR PLAN	Name	UnitBUA Type	UnitBUA Area	Carpet Area	No. of Rooms	No. of Tenement
FIRST FLOOR PLAN	SPLIT vv	SHOP	80.90	80.89	1	1
THIRD FLOOR PLAN	SPLIT A	FLAT	83.04	81.80	6	1
SECOND FLOOR PLAN	SPLIT vv	FLAT	81.20	80.93	1	1
Total	-	-	245.14	243.62	8	3

Building USE/SUBUSE Details

Building Name	Building Use	Building SubUse	Building Structure
A (AKHILESH KUMAR)	Residential	ResiComm Bldg	Non-Highrise

PLAN OF RAIN WATER RECHARGE PIT

Scale - (1:50)

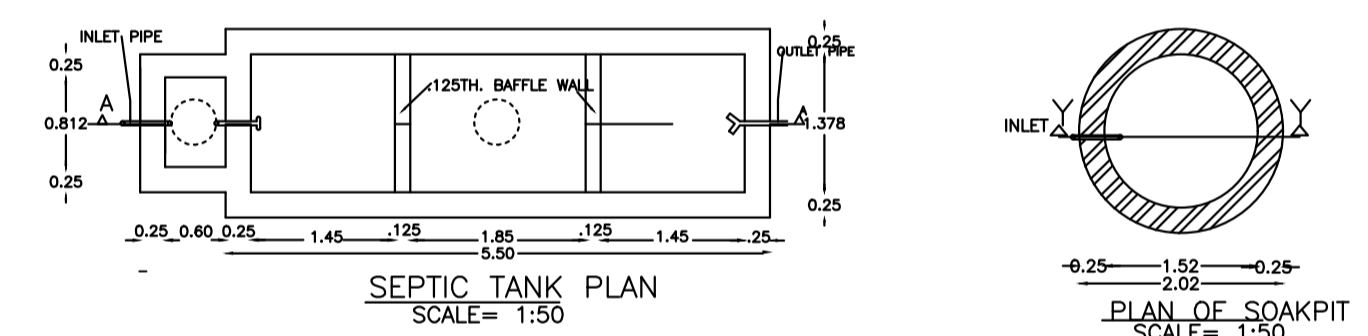
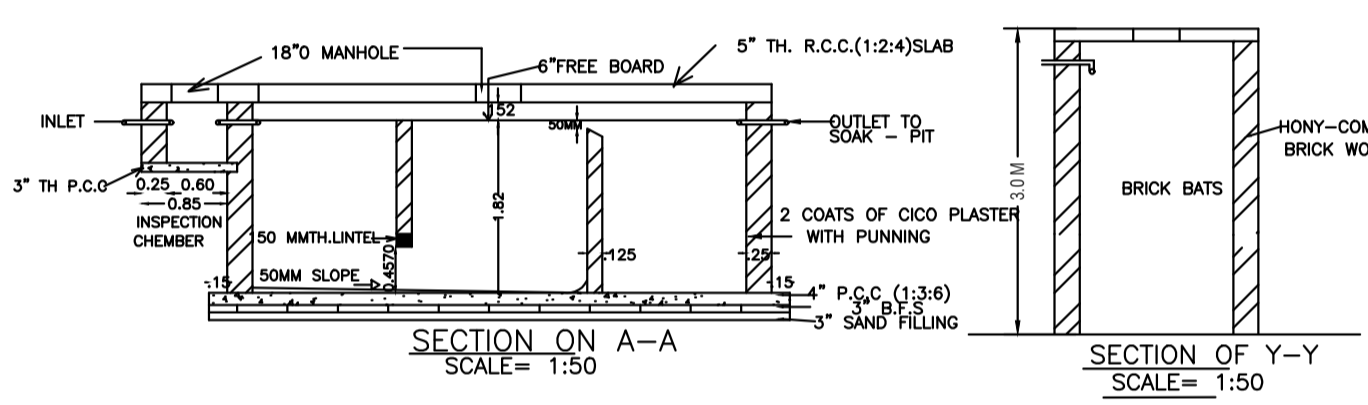
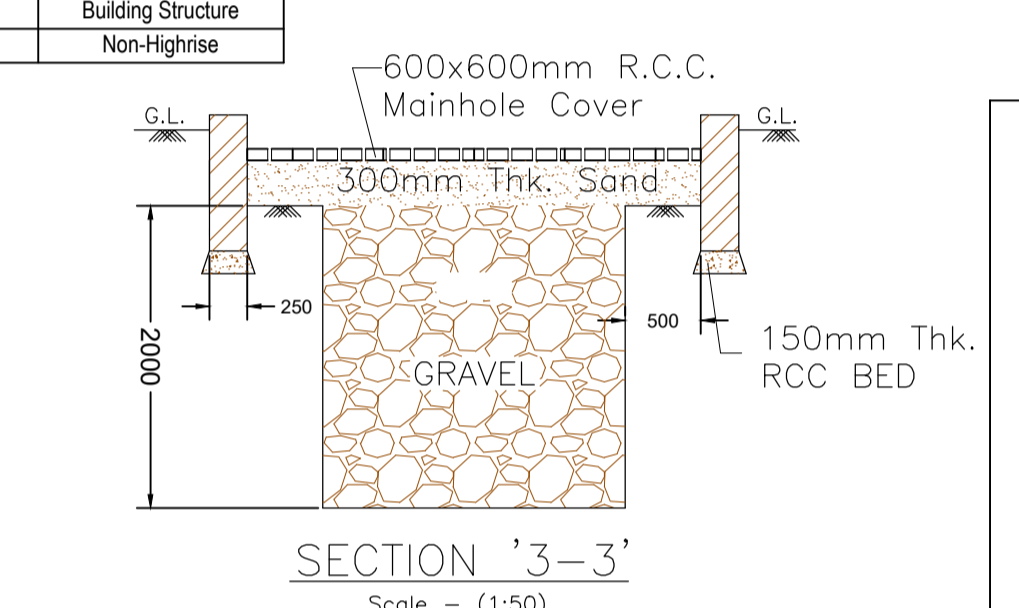

Buildingwise Floor FAR Details

Floor Name	Building Name		Total	
	Proposed Built Up Area (Sq.mt.)	Proposed FAR Area (Sq.mt.)	Total Proposed Built Up Area (Sq.mt.)	Total FAR Area (Sq.mt.)
Basement Floor	106.08	0.00	106.08	0.00
First Floor	106.08	106.08	106.08	106.08
Second Floor	106.08	106.08	106.08	106.08
Third Floor	106.08	106.08	106.08	106.08
Terrace Floor	0.00	0.00	0.00	0.00
Total :	424.32	318.24	424.32	318.24

FAR & Tenement Details (Table 4c-1)

Building	No. of Same Bldg	Total Built Up Area (Sq.mt.)	Deductions (Area in Sq.mt.)			Proposed FAR Area (Sq.mt.)	Total FAR Area (Sq.mt.)	Total Consumed Additional FAR Area (Sq.mt.)	Trmt (No.)
			Parking	Resi.	Commercial				
A (AKHILESH KUMAR)	1	424.32	106.08	212.16	106.08	318.24	318.24	03	
Grand Total :	1	424.32	106.08	212.16	106.08	318.24	318.24	03	

Required Parking (Table 7a)

Building Name	Type	SubUse	Area (Sq.mt.)	Units		Car		Visitors Car		TwoWheeler	
				Reqd.	Prop.	Reqd./Unit	Reqd.	Prop.	Reqd./Unit	Reqd.	Prop.
A (AKHILESH KUMAR)	Commercial	Shop	> 0	50	106.08	-	-	-	-	-	-
			> 0	50	106.08	-	-	-	1	5	-
	Residential	ResiComm Bldg	> 0	1	2.00	-	-	-	-	-	-
			> 0	1	2.00	-	-	-	1	2	-
Total :	-	-	-	-	-	4	4	1	1	7	8

Parking Check (Table 7b)

Vehicle Type	Reqd.		Prop.	
	No.	Area	No.	Area
Car	-	-	4	50.00
Total Car	4	50.00	4	50.00
Visitor's Car Parking	-	-	1	12.50
Total Visitor Parking	1	12.50	1	12.50
TwoWheeler	-	-	8	16.00
Total TwoWheeler	7	14.00	8	16.00
Other Parking	-	-	-	154.16
Total	76.50	-	248.66	-

AREA STATEMENT  
Hussainabad Nagar Panchayat

VERSION NO: 1.0.65  
VERSION DATE: 16/10/2020

PROJECT DETAIL:  
Region: JHARKHAND URBAN LOCAL BODIES  
District: PALAMU  
Authority: Hussainabad Nagar Panchayat  
Inward No: HNPC/BP/0035/W02/2023  
Application Type: General Proposal  
Project Type: Building Permission  
Nature of Development: New  
Location of Development Area: Old Area

Plot Use: Mixed  
Plot SubUse: Resi+Comm  
PlotNearby/Religious/Structure: NA  
North: -  
Plot/SubPlot No: 604.692  
South: -  
East: -  
West: -

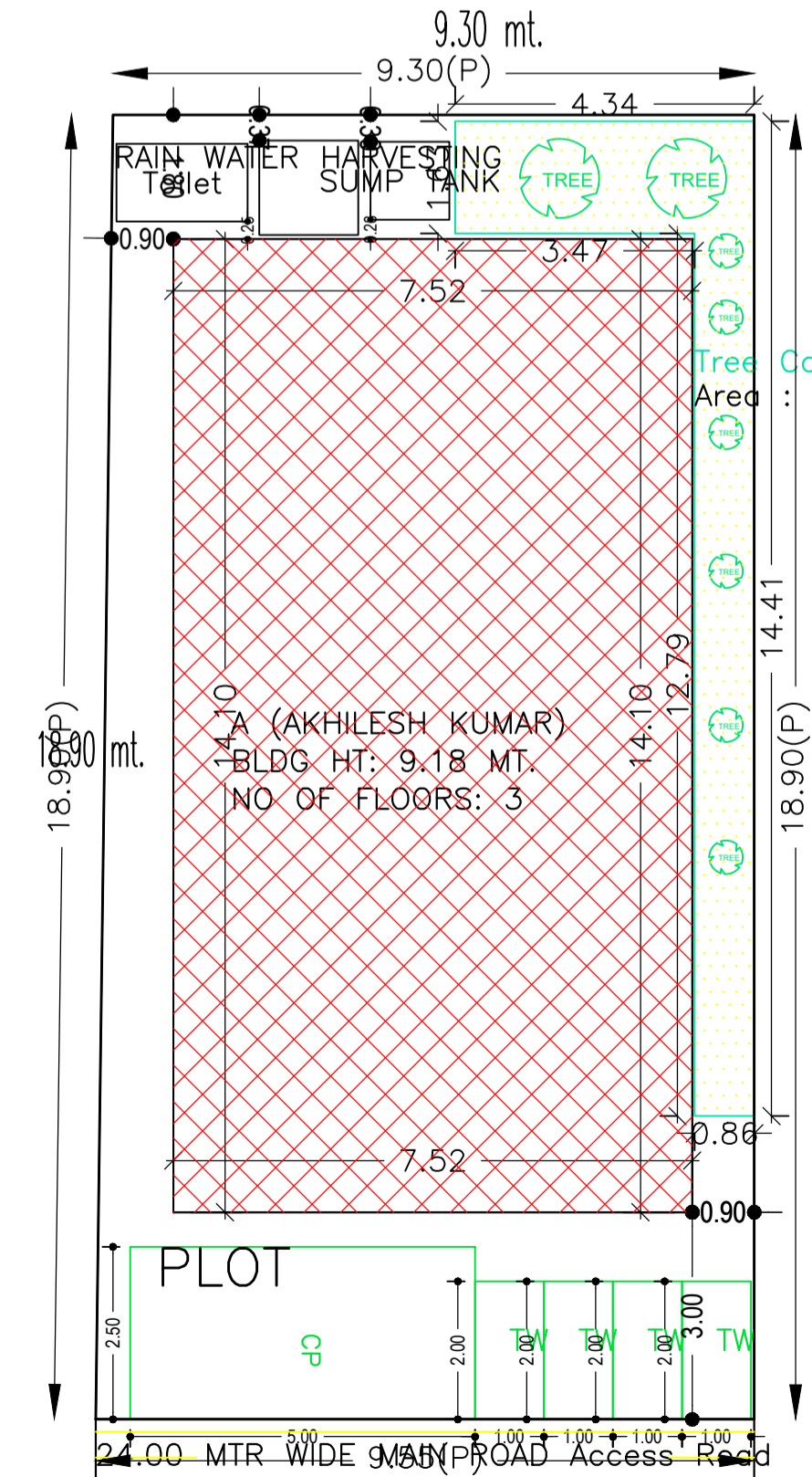

Tree Cover (Plantation) Area : 18.09

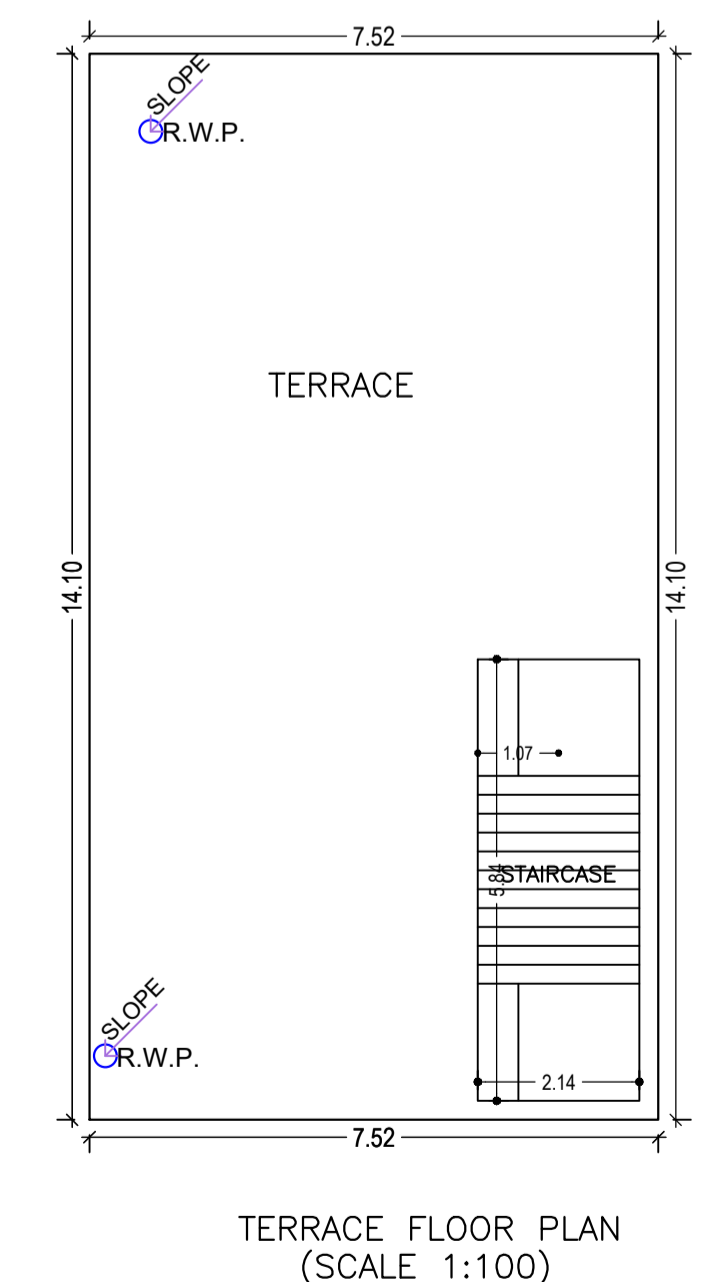
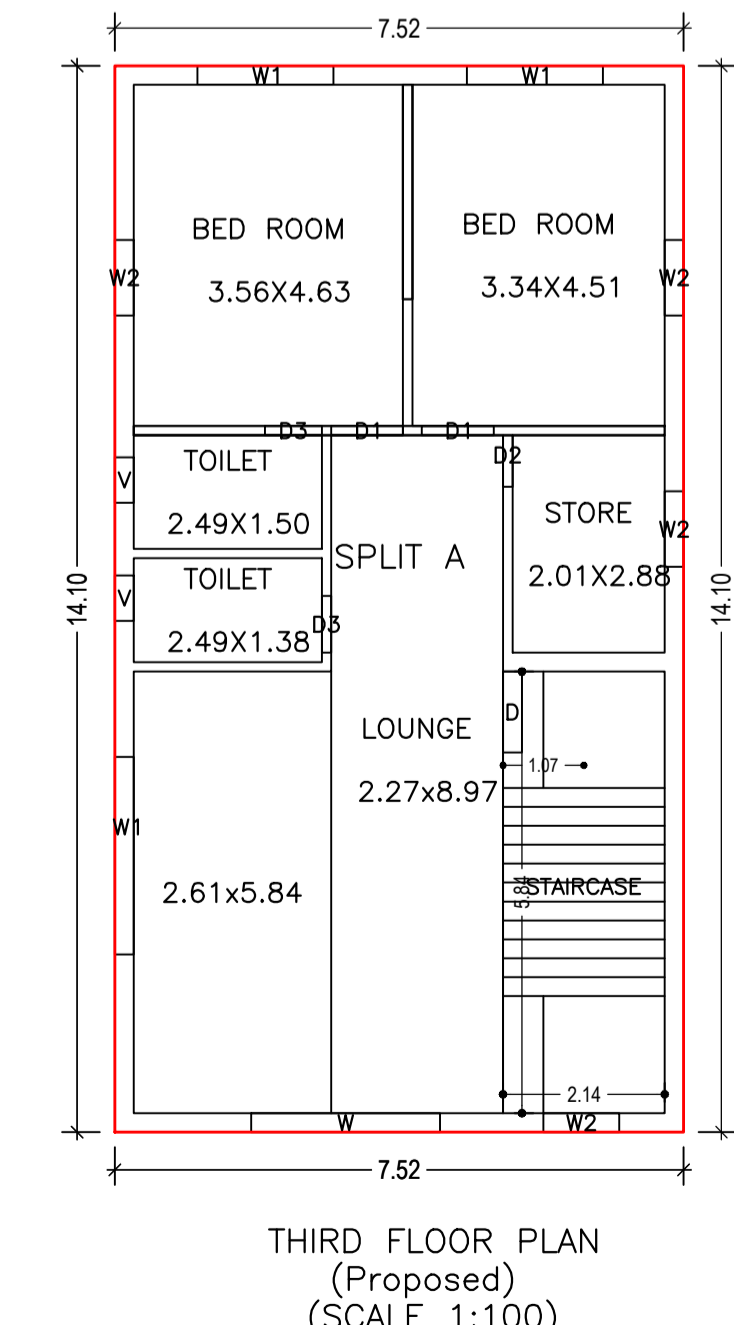
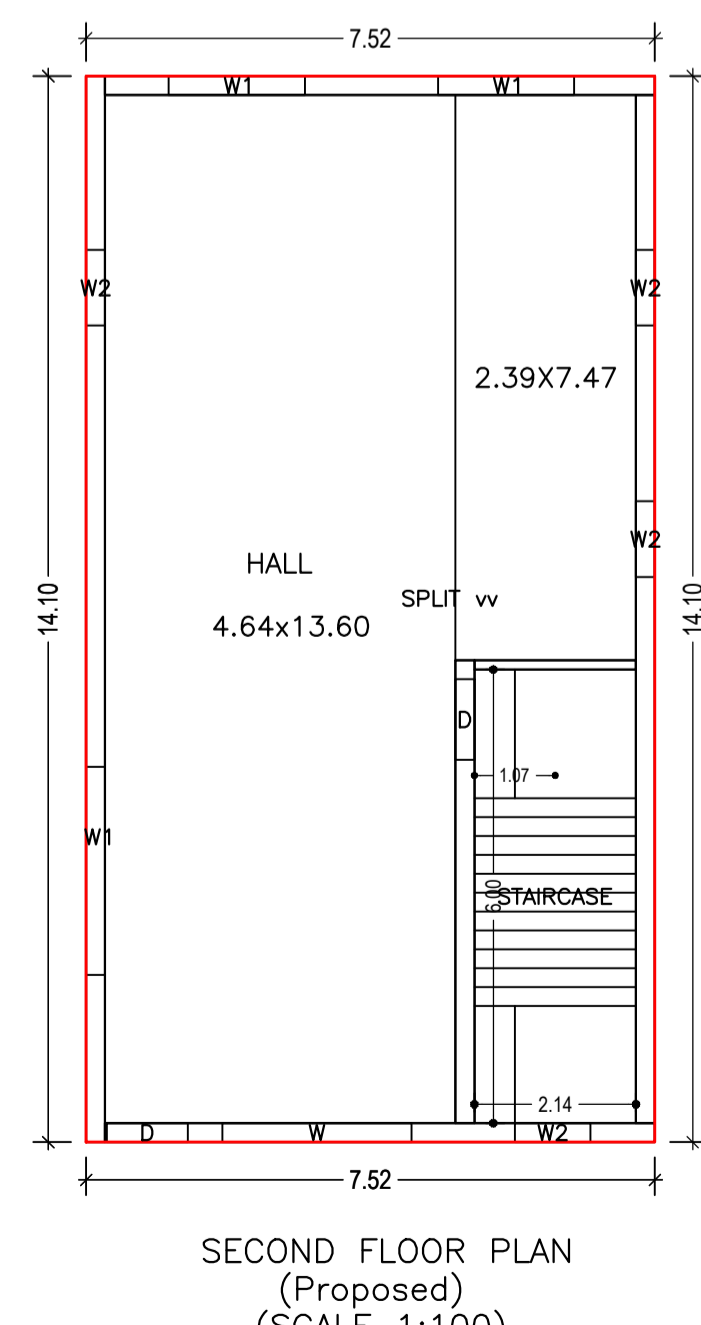
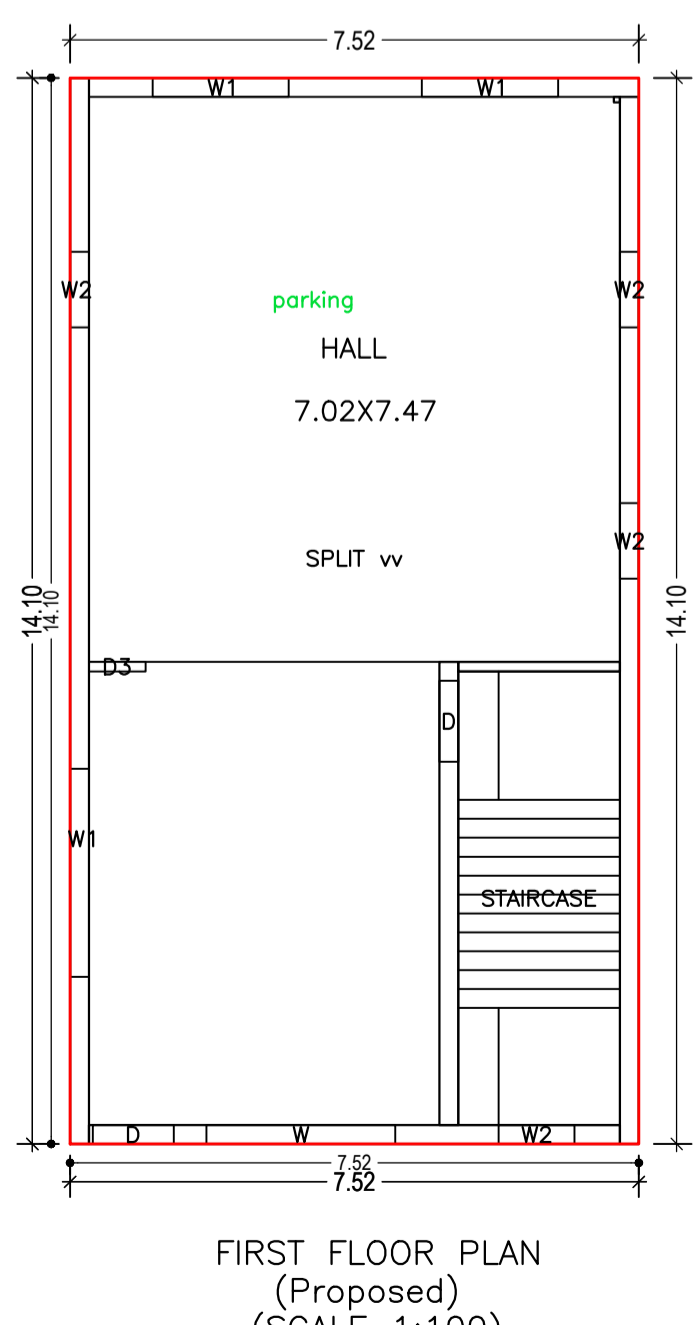
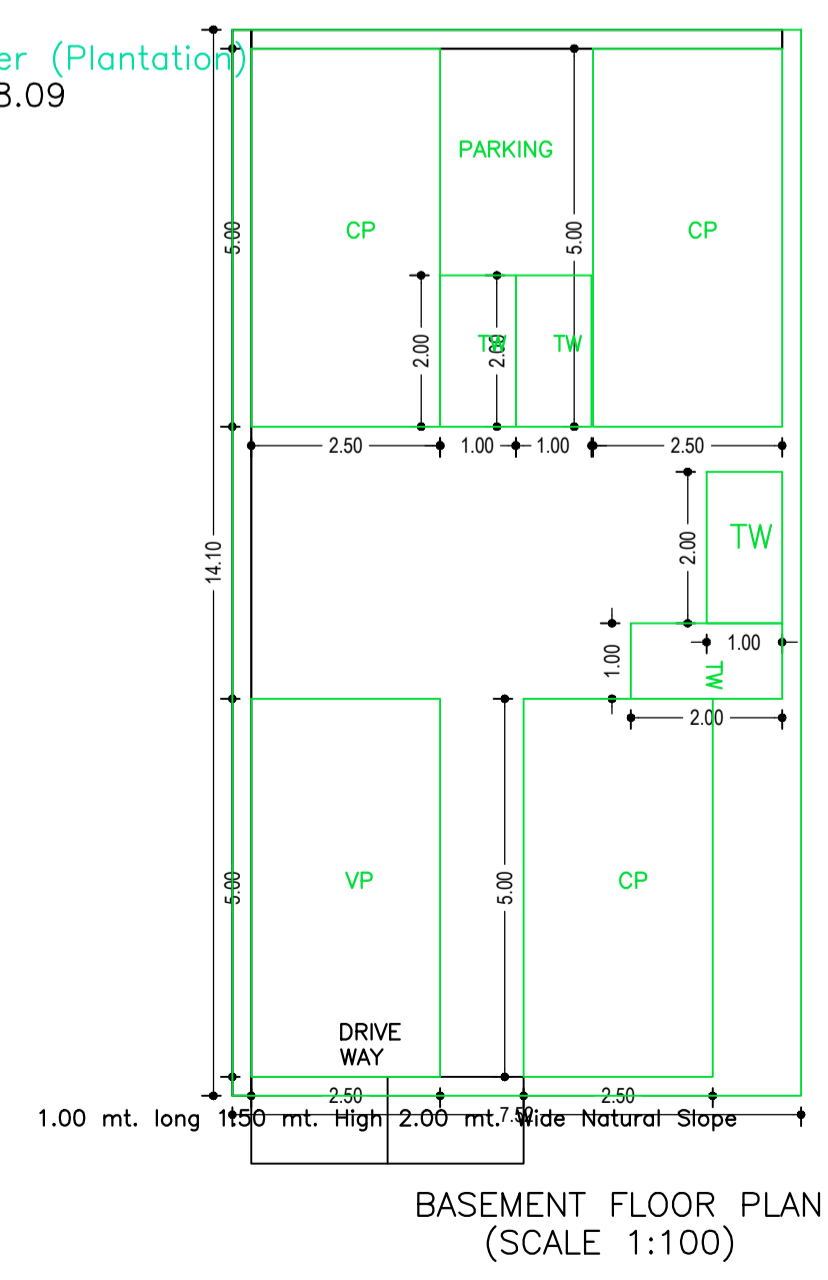

LTP NAME AND SIGNATURE	STRUCTURAL ENG'S NAME AND SIGNATURE	BUILDER NAME AND SIGNATURE	DIGITAL SIGNATURE
MERAJ SARWER ANSARI HNPC/ENG/0003/2021			