

SITE PLAN

FAR & Tenement Details (Table 4c-1)

Building	No. of Same Bldg	Total Built Up Area (Sq.mt.)	Proposed FAR Area (Sq.mt.) Resi.	Total FAR Area (Sq.mt.)	Total Consumed Additional FAR Area (Sq.mt.)	Tnmt (No.)
A (GYA PRASAD SAHU)	1	222.48	222.48	222.48	222.48	01
Grand Total :	1	222.48	222.48	222.48	222.48	01

Proposal Basis Information	
Proposal File No.	HNPC/BP/0067/W/14/2023
Owner Name	GAYA PRASADSAHU
Khata No	184
Plot No	55/2171
Village Name	Japla Dharahra
Use	Residential
SubUse	Bungalow/ Dwelling / Non Apartment

AREA STATEMENT		VERSION NO. : 1.0.68
Hussainabad Nagar Panchayat		VERSION DATE: 16/10/2020
PROJECT DETAIL:		
Region: JHARKHAND URBAN LOCAL BODIES	Plot Use: Residential	
District: PALAMU	Plot SubUse: Bungalow/ Dwelling / Non Apartment	
Authority: Hussainabad Nagar Panchayat	PlotNearbyReligiousStructure: NA	
Inward No: HNPC/BP/0067/W/14/2023	PlotSubPlot No: 55/2171	
Application Type: General Proposal	North: -	
Project Type: Building Permission	South: -	
Nature of Development: New	East: -	
Location of Development Area: Old Area	West: -	
AREA DETAILS:		
AREA OF PLOT (Minimum)	(A)	SQ.MT. 439.67
NET AREA OF PLOT(Gross Plot Area - Deduction from Gross Plot area)	(A-Deductions)	439.67
Deduction for Balance Plot Area(from Gross Plot Area)		
Common Plot		42.67
Total		42.67
BALANCE AREA OF PLOT(Net Plot Area - Recreational/Amenity space)	(A-Deductions)	397.00
PLOT AREA FOR COVERAGE(Net Plot Area)	(A-Deductions)	439.67
Plot Area for FAR (Net Plot Area + RoadWidening Area)	(A-Deductions)	439.67
COVERAGE CHECK		
Permissible Coverage area ( 60.00 % )		263.80
Proposed Coverage Area ( 25.30 % )		111.24
Total Prop. Coverage Area ( 25.3 % )		111.24
Balance coverage area ( 34.70 % )		152.56
FAR CHECK		
Perm. FAR Area ( 1.500 )		659.51
Total Perm. FAR area		659.51
Residential FAR		222.48
Proposed FAR Area		222.48
Total Proposed FAR Area		222.48
Consumed FAR (Factor)		0.51
Balance FAR Area		437.03
BUILT UP AREA CHECK		
Total Proposed BuiltUp Area		222.48
ARCHITECT (Regd)	Anuj Kumar Paswan	
ENGINEER (Regd)		
SUPERVISOR (Regd)		
OWNER (Regd)	GAYA PRASADSAHU	
DEVELOPMENT AUTHORITY		LOCAL BODY

COLOR INDEX	
PLOT BOUNDARY	Black
ABUTTING ROAD	Green
PROPOSED CONSTRUCTION	Red
COMMON PLOT	Yellow
ROAD WIDENING AREA	Orange
EXISTING (To be retained)	Blue
EXISTING (To be demolished)	Light Blue

Buildingwise Floor FAR Details

Floor Name	Building Name A (GYA PRASAD SAHU)		Total	
	Proposed Built Up Area (Sq.mt.)	Proposed FAR Area (Sq.mt.)	Total Proposed Built Up Area (Sq.mt.)	Total FAR Area (Sq.mt.)
Ground Floor	111.24	111.24	111.24	111.24
First Floor	111.24	111.24	111.24	111.24
Terrace Floor	0.00	0.00	0.00	0.00
Total :	222.48	222.48	222.48	222.48

Building USE/SUBUSE Details

Building Name	Building Use	Building SubUse	Building Structure
A (GYA PRASAD SAHU)	Residential	Bungalow/ Dwelling / Non Apartment	Non-Highrise

LTP NAME AND SIGNATURE	STRUCTURAL ENG'S NAME AND SIGNATURE	BUILDER NAME AND SIGNATURE	DIGITAL SIGNATURE
Anuj Kumar Paswan HNPC/ENG/0002/2022			



Proposal Basic Information	
Proposal File No.	HNPC/BP/0067/W/14/2023
Owner Name	GAYA PRASADSAHU
Khata No	184
Plot No	55/2171
Village Name	Japla Dharahra
Use	Residential
SubUse	Bungalow/ Dwelling / Non Apartment

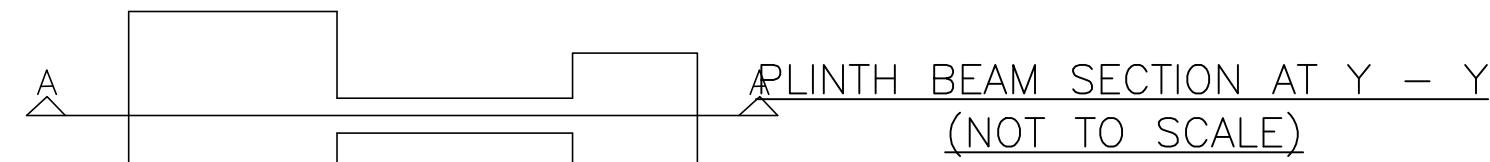
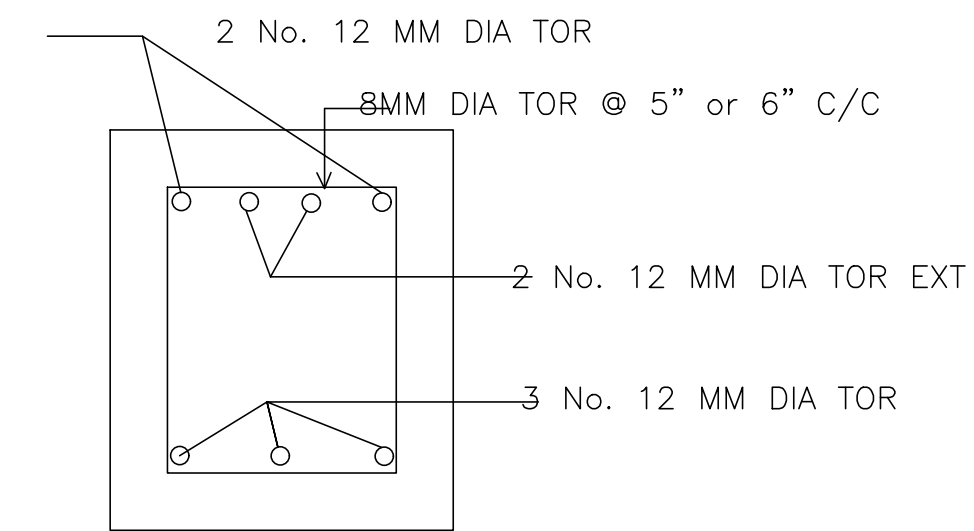
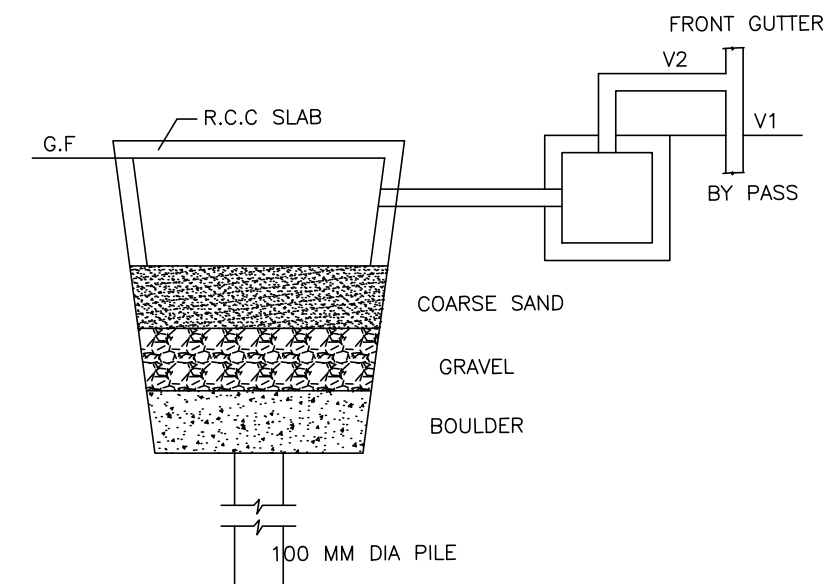
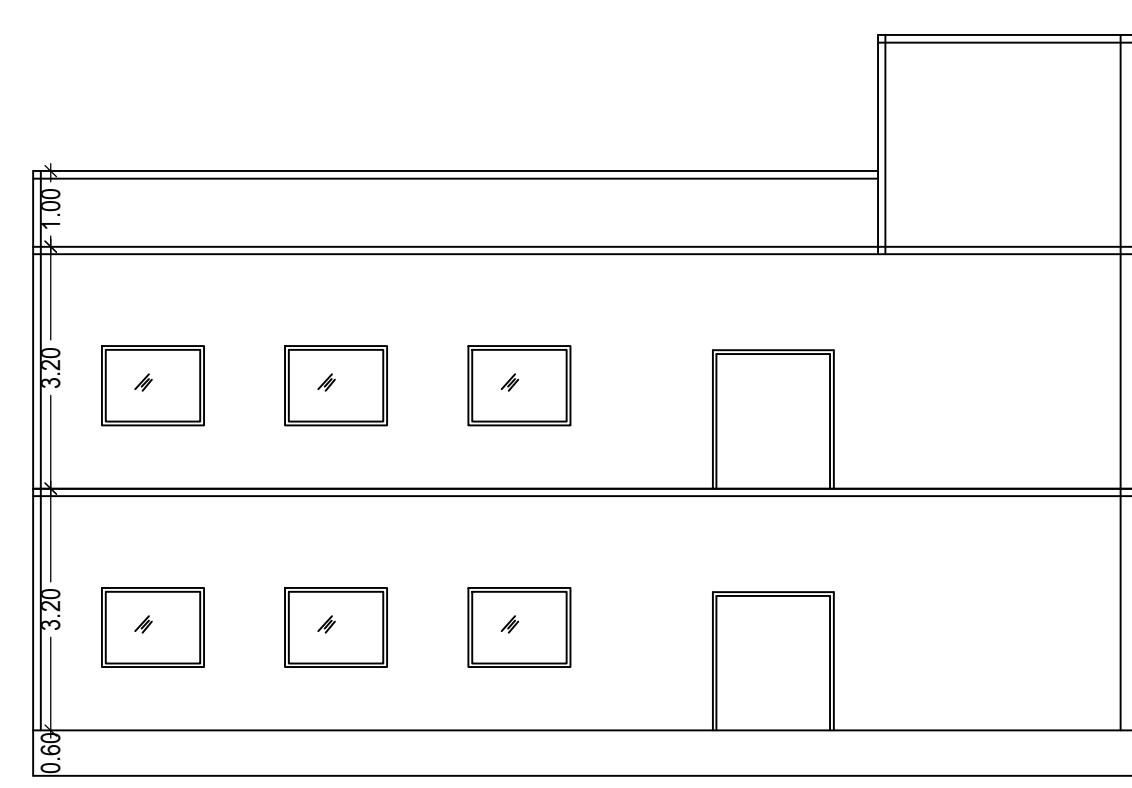
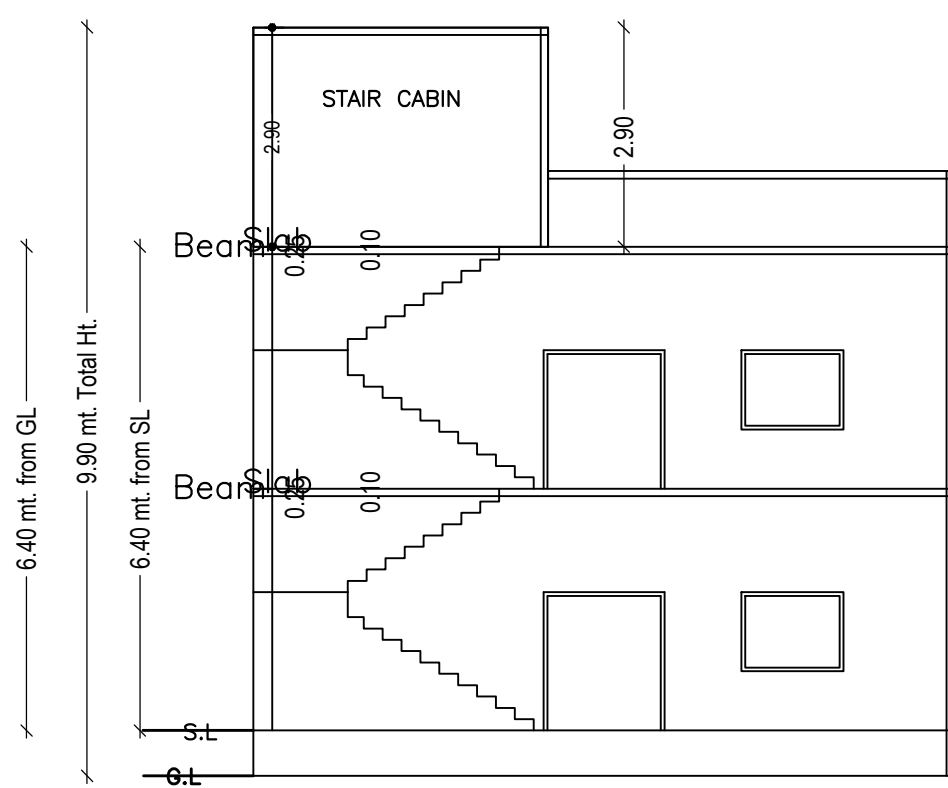
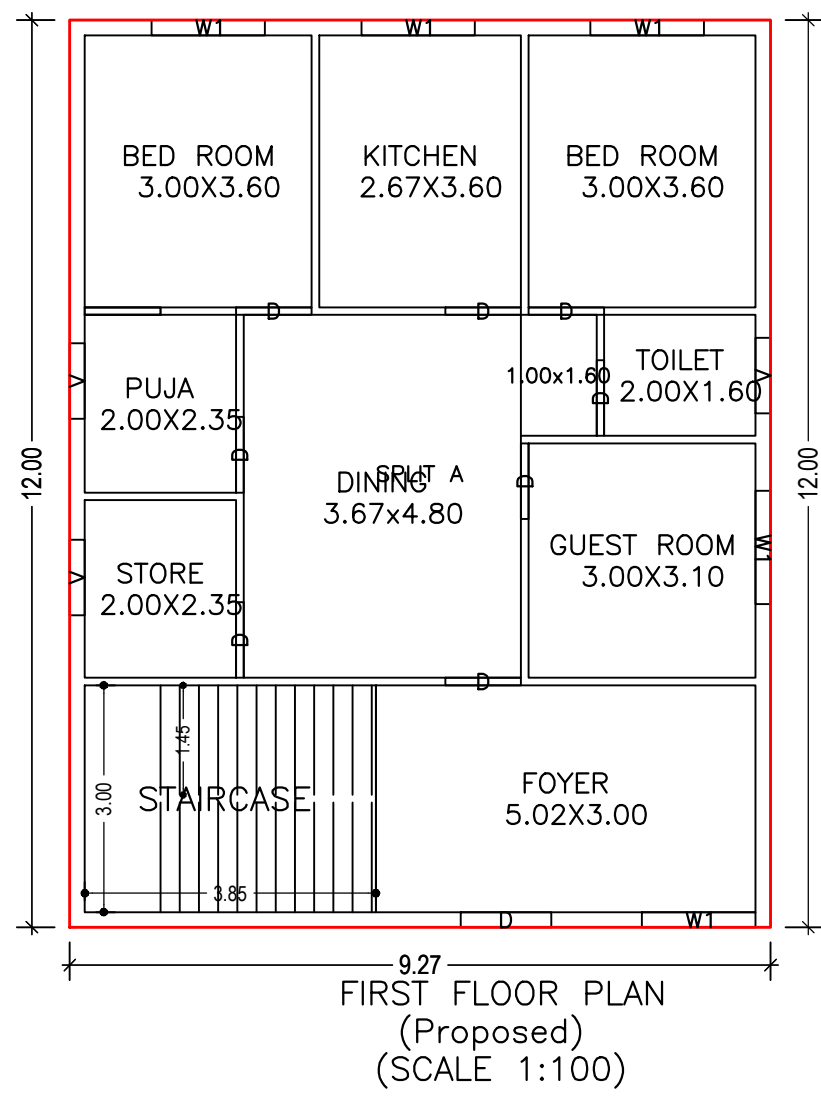
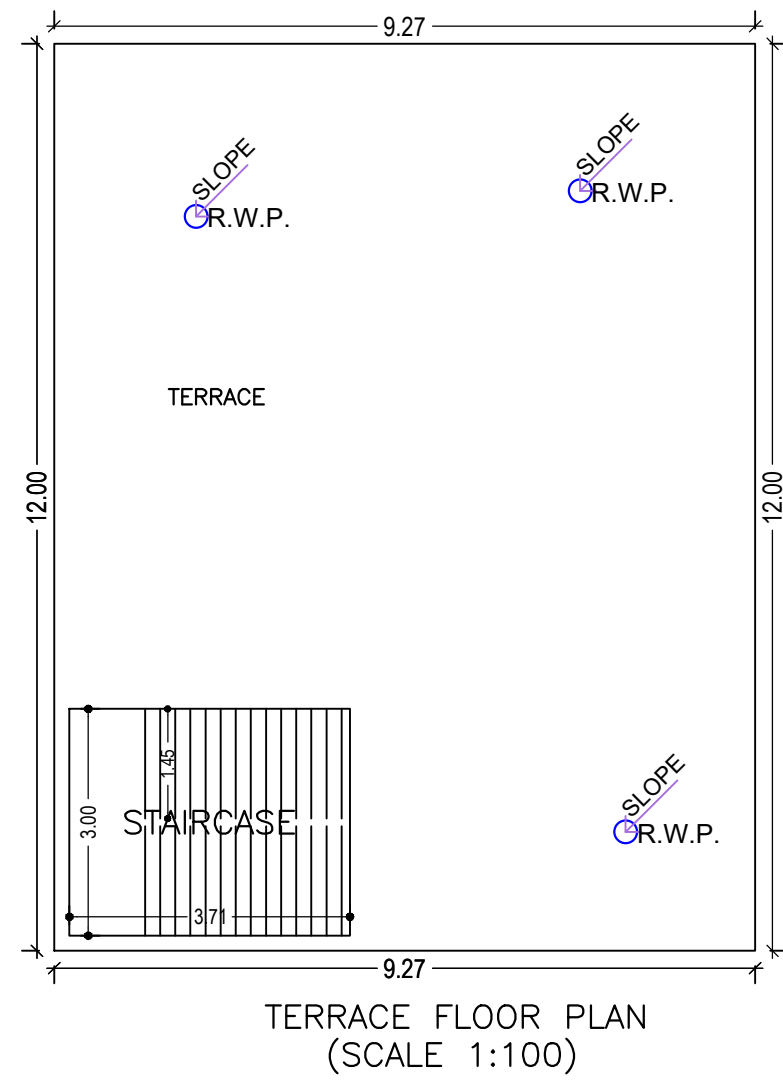
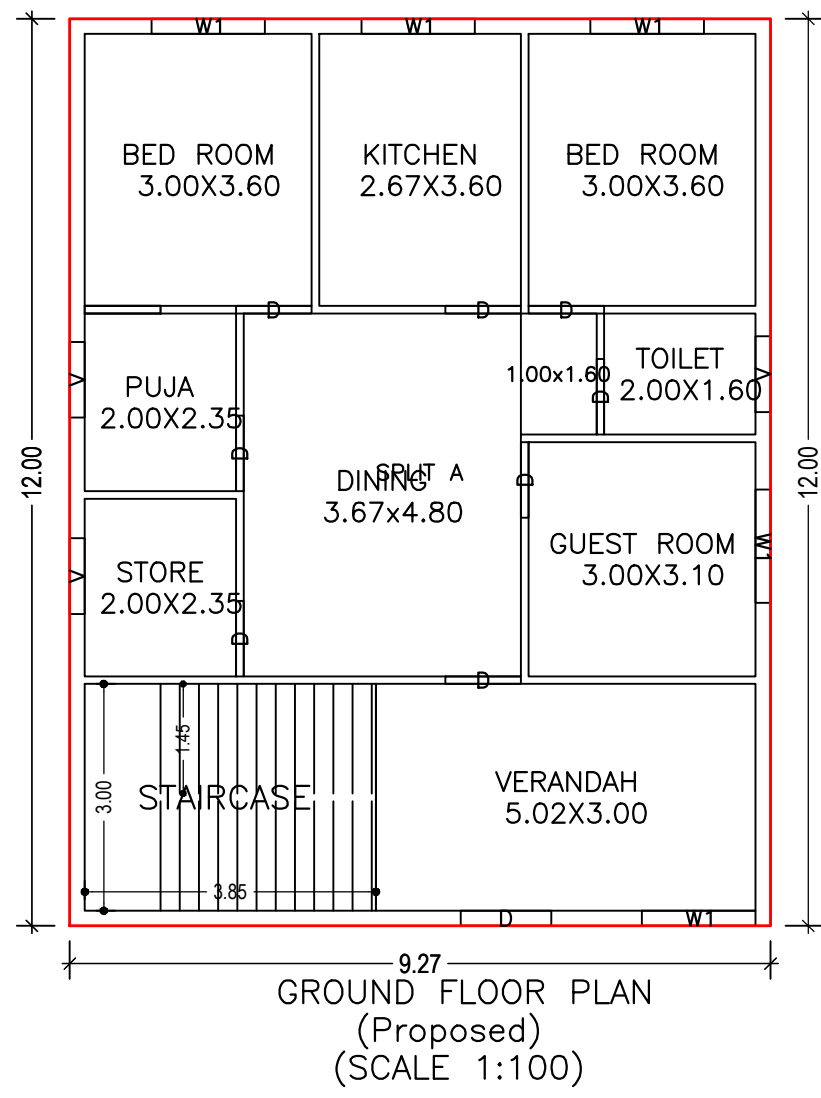

DET. OF RECHARGEABLE BORE WELL

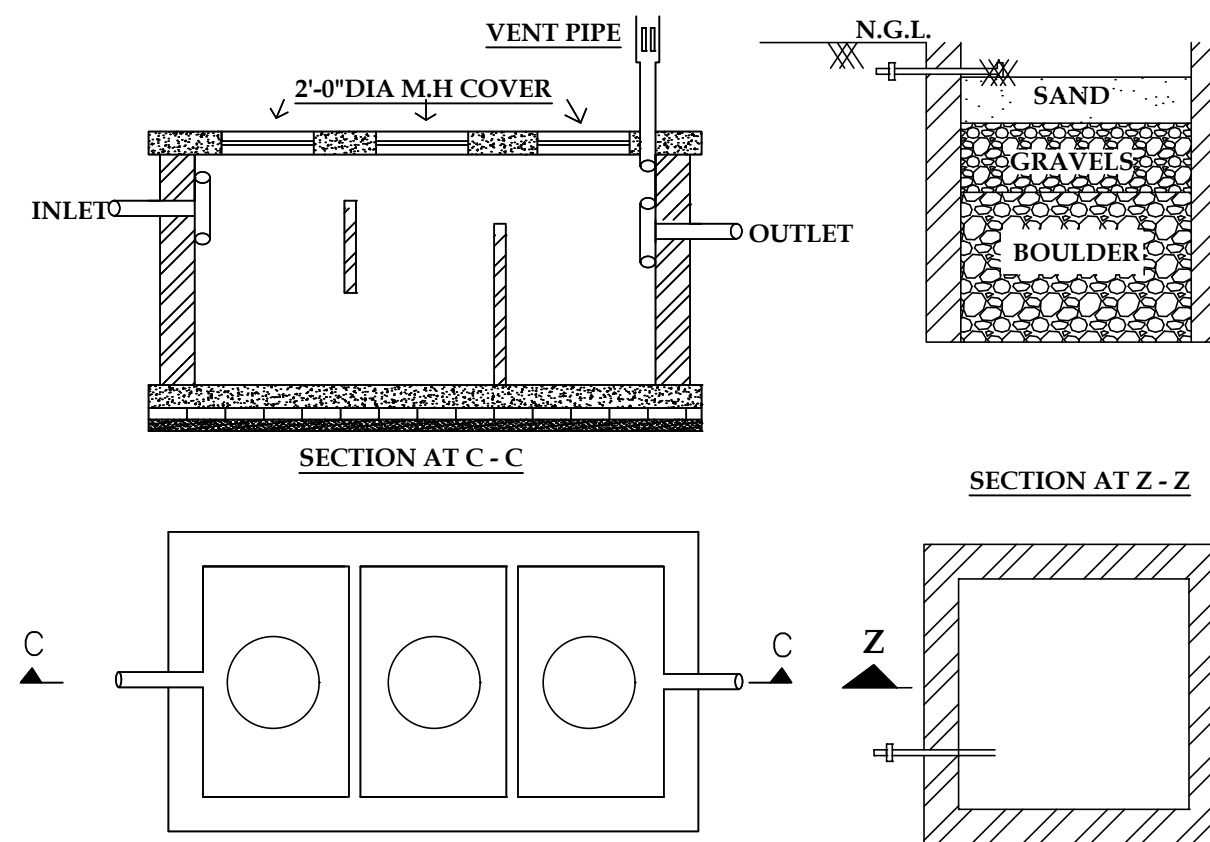
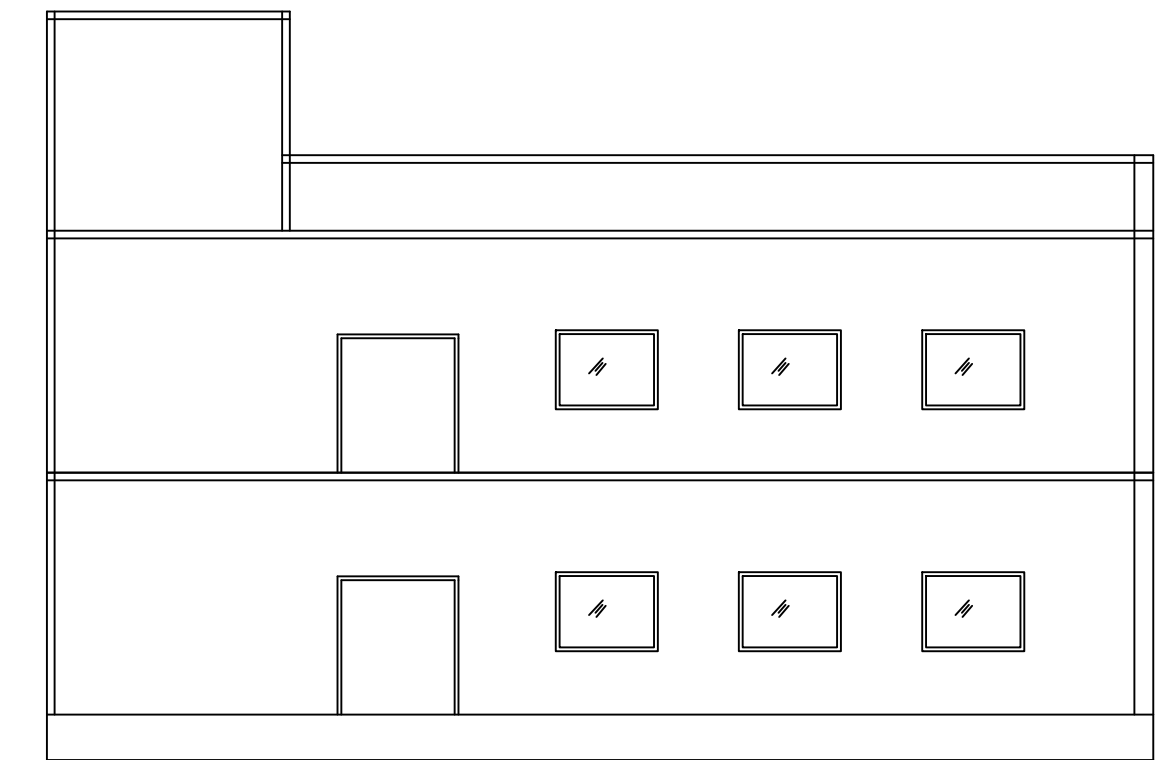
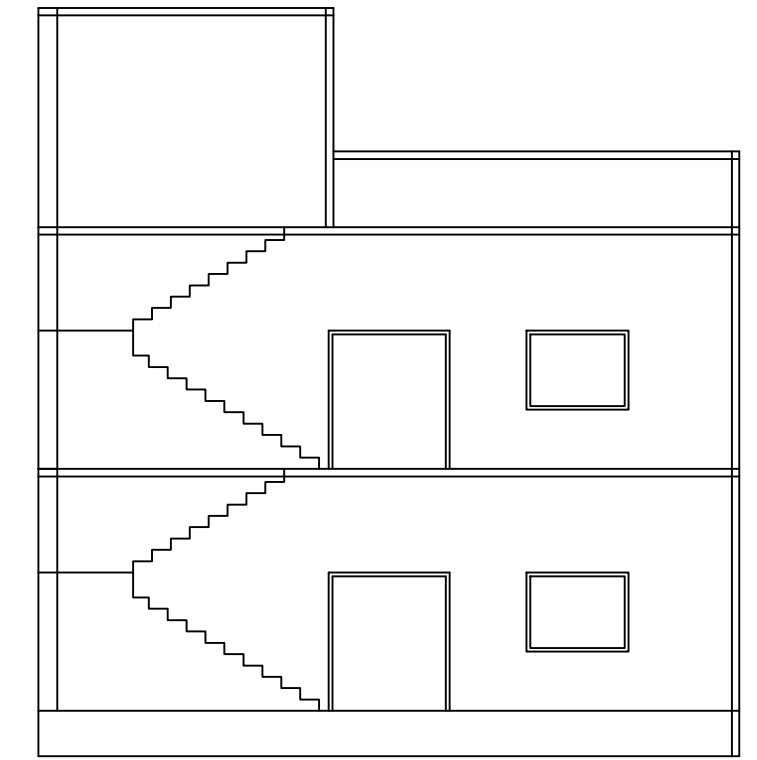
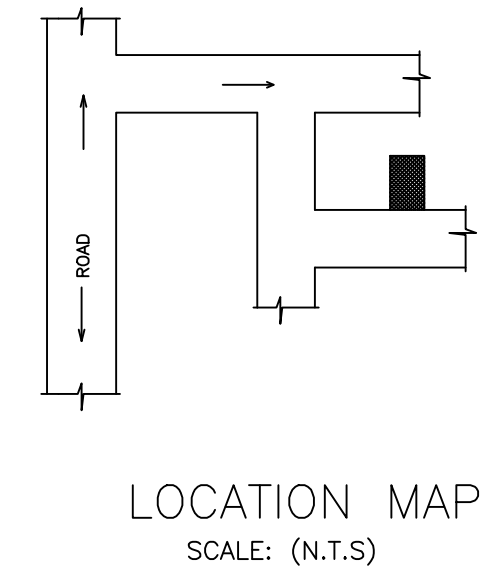

PLAN DET. OF SEPTIC TANK (SCALE = 1:48)

R.W.H PLAN (SCALE = 1:48)

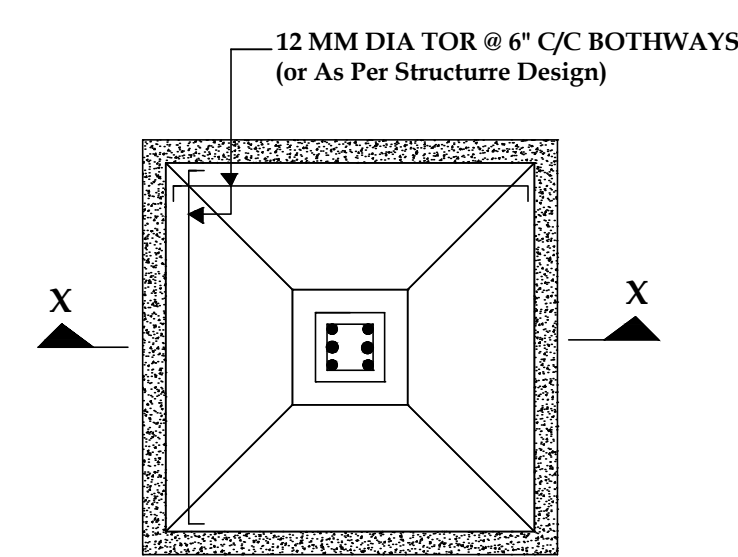

PLAN DET. OF FOUNDATION (SCALE = 1:24)

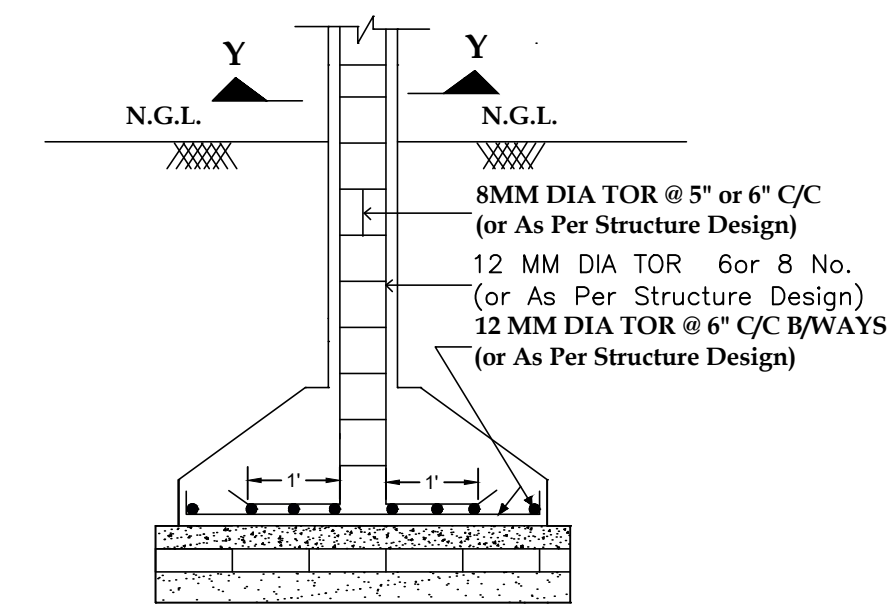

SECTION AT X - X (SCALE = 1:24)

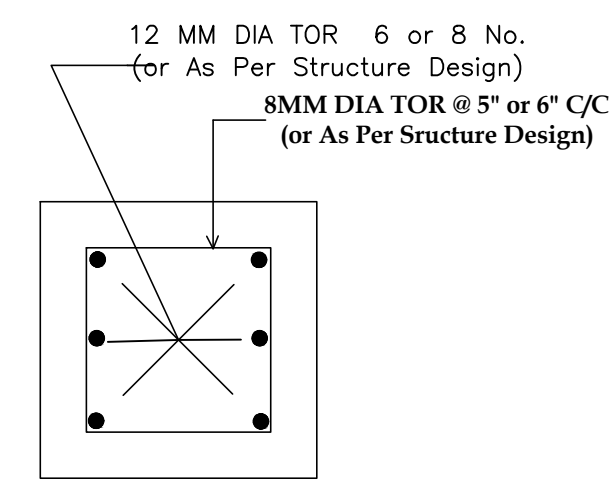

COLUMN SECTION AT Y - Y (NOT TO SCALE)

Building :A (GYA PRASAD SAHU)

Floor Name	Total Built Up Area (Sq.mt.)	Proposed FAR Area (Sq.mt.)	Total FAR Area (Sq.mt.)	Total Consumed Additional FAR Area (Sq.mt.)	Tnmt (No.)
Ground Floor	111.24	111.24	111.24	111.24	01
First Floor	111.24	111.24	111.24	111.24	00
Terrace Floor	0.00	0.00	0.00	0.00	00
Total:	222.48	222.48	222.48	222.48	01
Total Number of Same Buildings	1				
Total:	222.48	222.48	222.48	222.48	01

SCHEDULE OF DOOR:

BUILDING NAME	NAME	LENGTH	HEIGHT	NOS
A (GYA PRASAD SAHU)	D	1.00	2.10	16
A (GYA PRASAD SAHU)	D	1.20	2.10	02

SCHEDULE OF WINDOW/VENTILATION:

BUILDING NAME	NAME	LENGTH	HEIGHT	NOS
A (GYA PRASAD SAHU)	V	1.00	1.20	06
A (GYA PRASAD SAHU)	W1	1.50	1.20	10

UnitBUA Table for Building :A (GYA PRASAD SAHU)

FLOOR	Name	UnitBUA Type	UnitBUA Area	Carpet Area	No. of Rooms	No. of Tenement
GROUND FLOOR PLAN	SPLIT A	FLAT	181.92	181.72	9	1
FIRST FLOOR PLAN	SPLIT A	FLAT	0.00	0.00	9	0
Total:	-	-	181.92	181.72	18	1

LTP NAME AND SIGNATURE	STRUCTURAL ENG'S NAME AND SIGNATURE	BUILDER NAME AND SIGNATURE	DIGITAL SIGNATURE
Anuj Kumar Paswan HNPC/ENG/0002/2022			



Proposal Bas Information	
Proposal File No	HNPC/BP/0067/W/14/2023
Owner Name	GAYA PRASADSAHU
Khata No	184
Plot No	55/2171
Village Name	Japla Dharahra
Use	Residential
SubUse	Bungalow/ Dwelling / Non Apartment

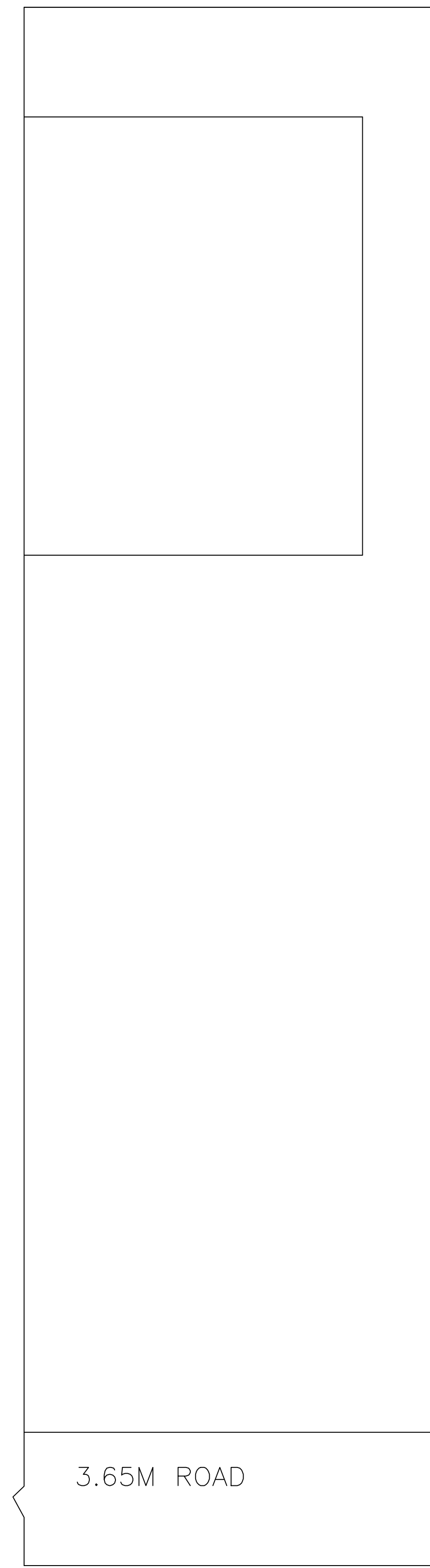

3.65M ROAD

LTP NAME AND SIGNATURE	STRUCTURAL ENG'S NAME AND SIGNATURE	BUILDER NAME AND SIGNATURE	DIGITAL SIGNATURE
Anuj Kumar Paswan HNPC/ENG/0002/2022			