

Project Title: SAURAV KUMAR GUTGUTIA & HARSH KUMAR GUTGUTIA

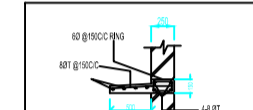

DET. OF R.C.C. BEAM SCALE: 1:20

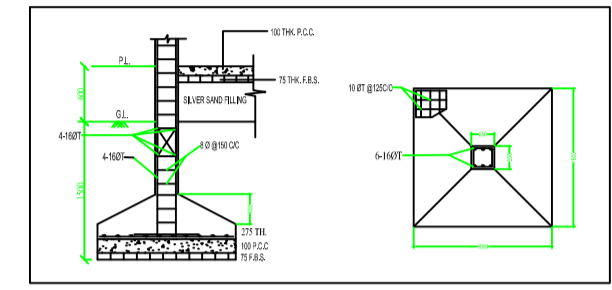
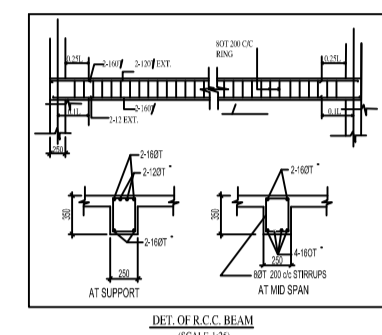
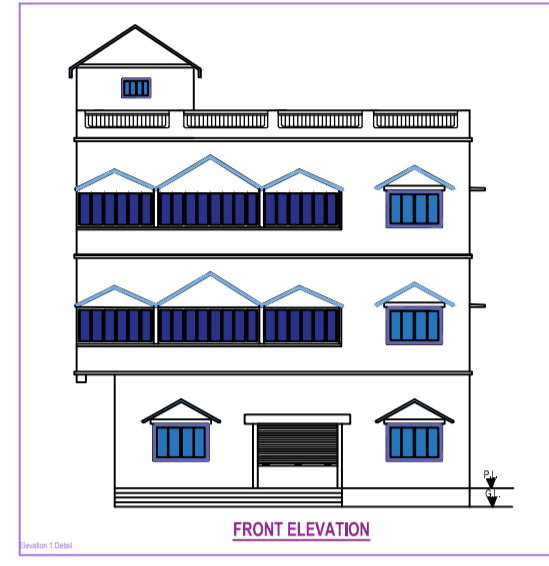
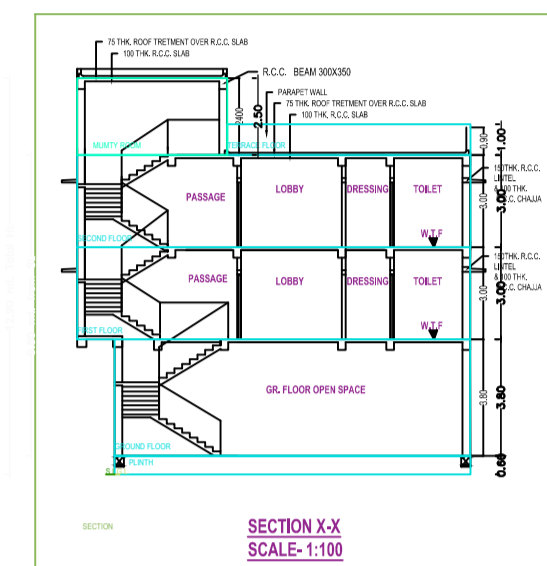
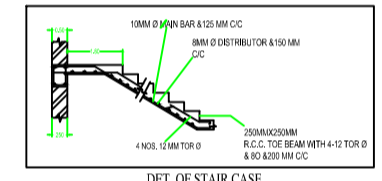
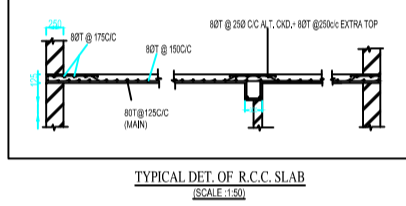
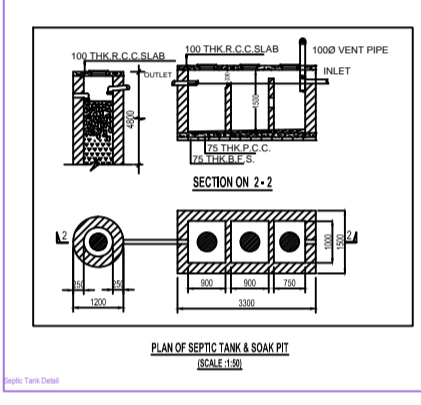
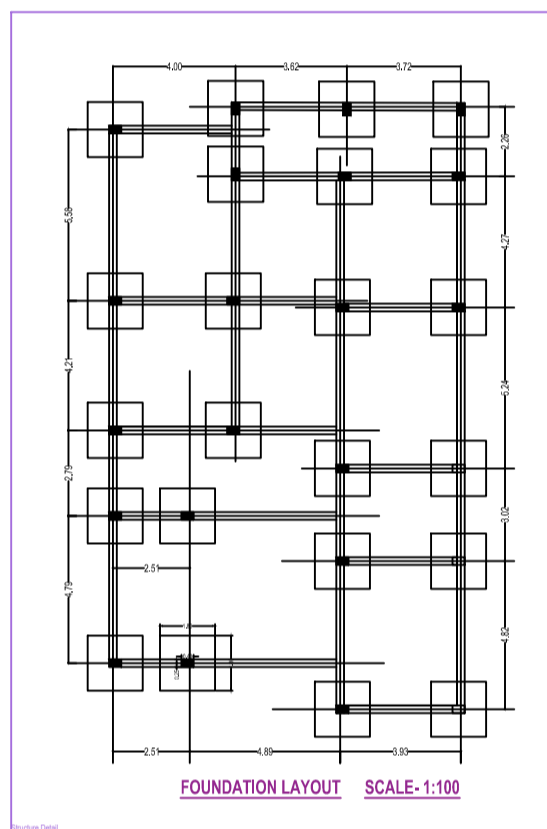
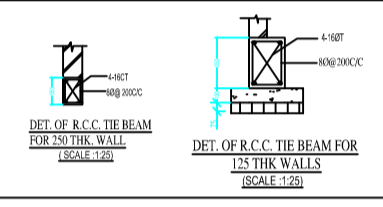

SHEET NO - 22  
**PROPOSED PLAN OF THREE STORED RESIDENTIAL BUILDING OF SAURAV KUMAR GUTGUTIA & HARSH KUMAR GUTGUTIA AT HOLDING NO.-00/00/00/00/00, PLOT NO.-53/54/1, KHATA NO.-60/15/5/0/1, J.L. NO.-06, THANA NO.-06, MOUZA-DHANDRA, WARD NO.-06, UNDERJAMTARA NAGAR PANCHAYAT.**

**NOTES**  
 1. ALL DIMENSIONS ARE IN METERS UNLESS OTHERWISE SPECIFIED.  
 2. ALL DIMENSIONS ARE TO FACE UNLESS OTHERWISE SPECIFIED.  
 3. ALL DIMENSIONS ARE TO BE FOLLOWED.  
 4. ALL DIMENSIONS ARE TO BE FOLLOWED.  
 5. ALL DIMENSIONS ARE TO BE FOLLOWED.

**DOORS & WINDOWS SCHEDULE**

Sl. No.	Qty.	Size	Material	Remarks
01	01	2.10 x 2.10	WOODEN DOOR	MAIN DOOR
02	01	2.10 x 2.10	WOODEN DOOR	STAIR DOOR
03	01	2.10 x 2.10	WOODEN DOOR	ROOM DOOR
04	01	2.10 x 2.10	WOODEN DOOR	TOILET DOOR
05	01	2.10 x 2.10	WOODEN DOOR	TOILET DOOR
06	01	2.10 x 2.10	WOODEN DOOR	TOILET DOOR
07	01	2.10 x 2.10	WOODEN DOOR	TOILET DOOR
08	01	2.10 x 2.10	WOODEN DOOR	TOILET DOOR
09	01	2.10 x 2.10	WOODEN DOOR	TOILET DOOR
10	01	2.10 x 2.10	WOODEN DOOR	TOILET DOOR

SCALE: 1:200 (1:100, 1:50, 1:25)  
 ALL DIMENSIONS ARE IN METERS

**AREA STATEMENT**

Particulars	Area (sq.m)
TOTAL AREA OF LAND AREA	406.77
PROP. GROUND FLOOR COVER AREA	229.88
PROP. FIRST FLOOR COVER AREA	205.83
PROP. SECOND FLOOR COVER AREA	205.83
PROP. TOTAL COVER AREA	741.54
OPEN SPACE LEFT	466.79
HEIGHT FROM G.L. TO F.L.	4.00
TOTAL HEIGHT OF THE BUILDING	12.00
TOTAL STORED	THREE
NO. OF SEPTIC TANK	ONE
NO. OF TOILET	TEN
NO. OF STAIR CASE	ONE

SIGNATURE OF OWNER

SIGNATURE OF ENGINEER

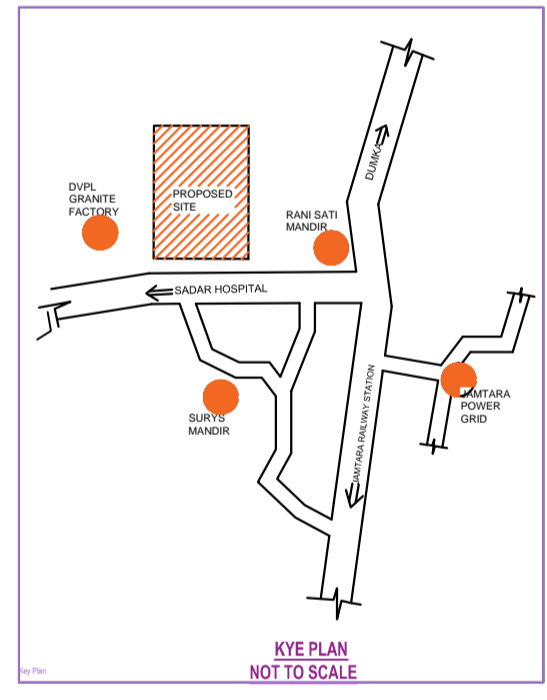
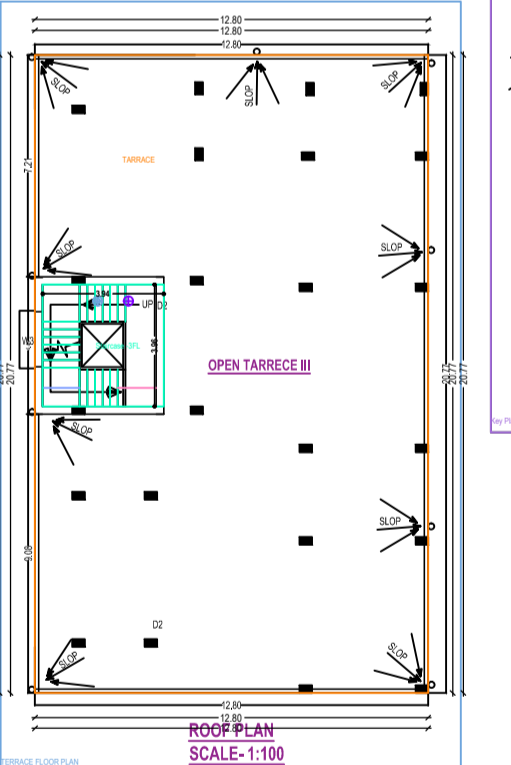
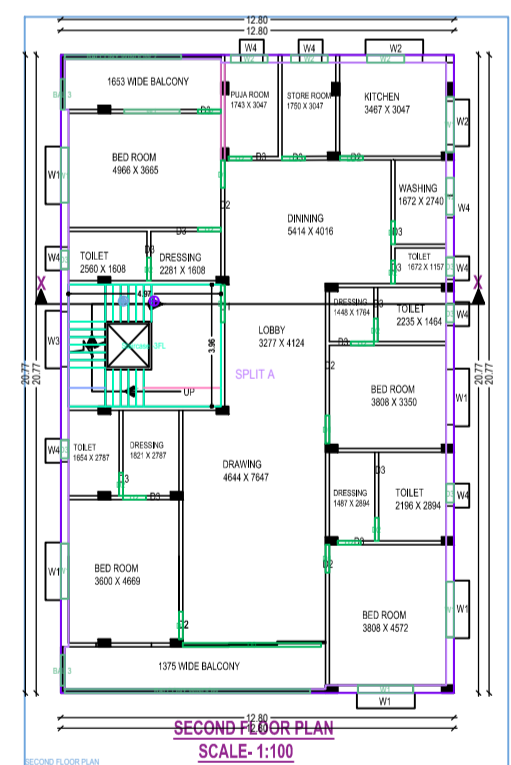
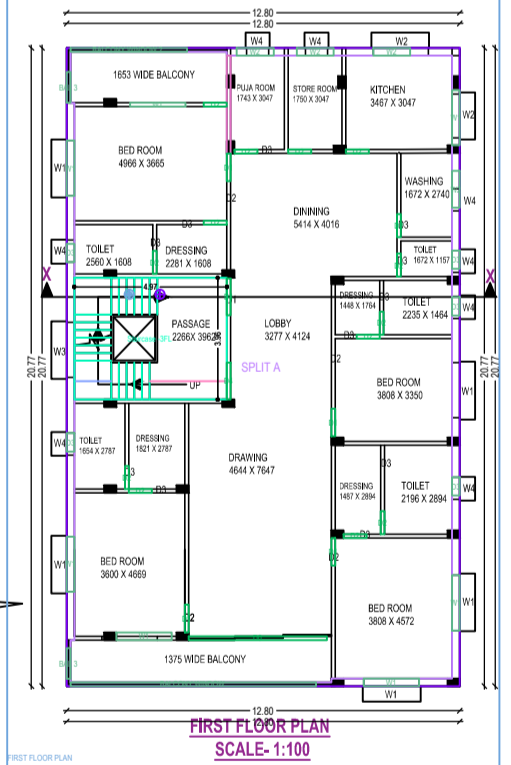
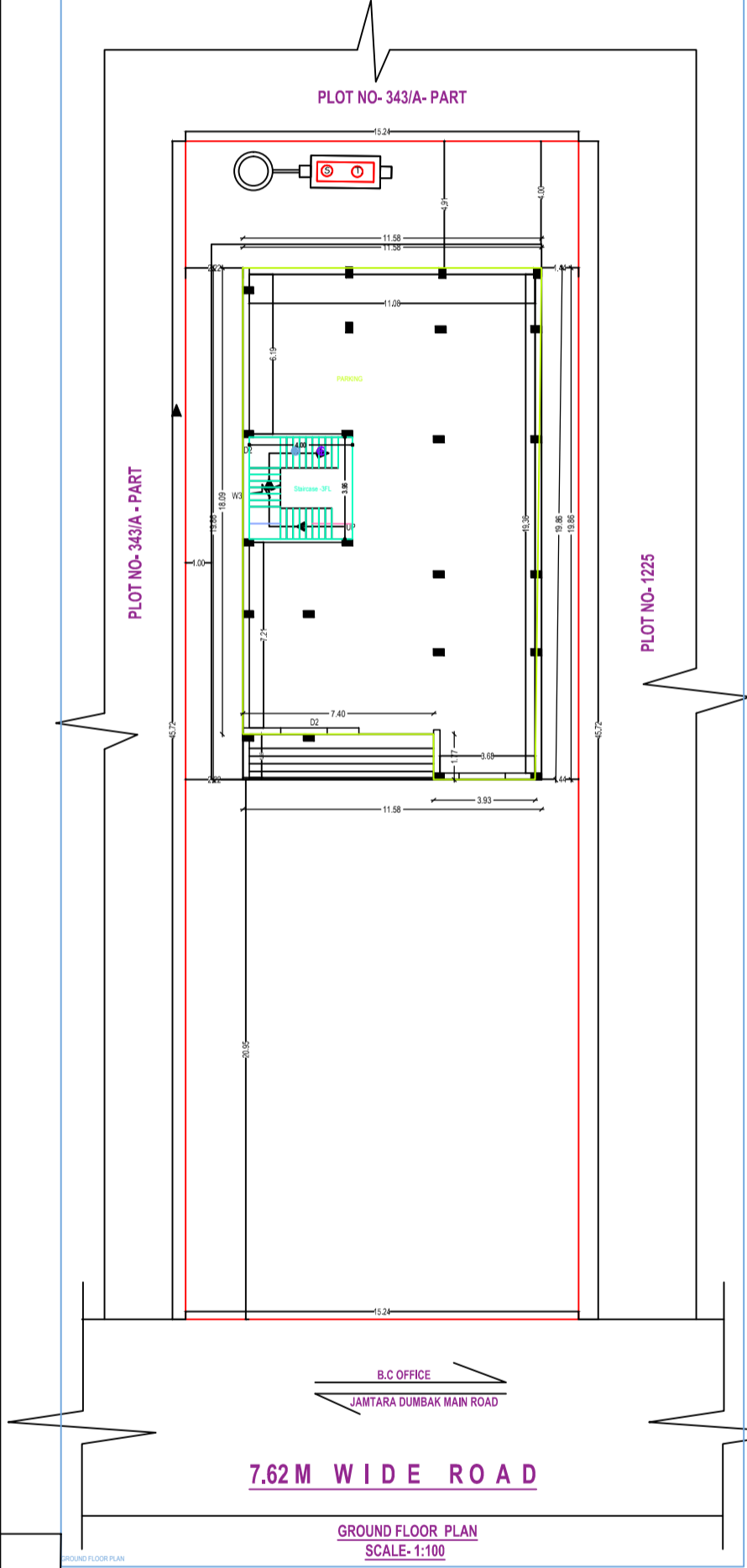
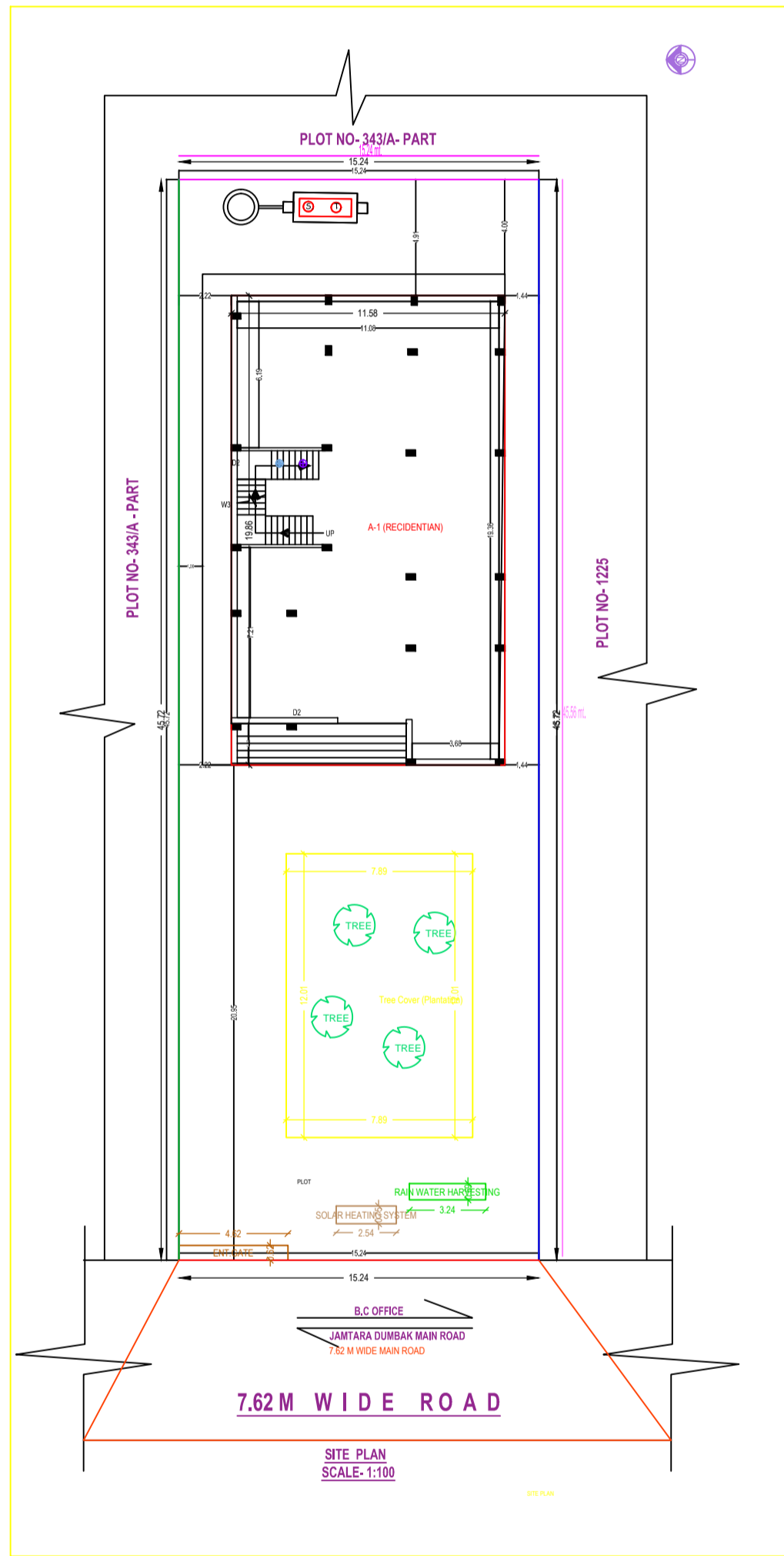

**Building A (RECCENTAN)**

Sl. No.	Particulars	Area (sq.m)	Volume (cu.m)	Remarks
01	Ground Floor	229.88	919.52	
02	First Floor	205.83	823.32	
03	Second Floor	205.83	823.32	
04	Total	641.54	2566.16	

**SCHEDULE OF JOINTS**

Sl. No.	Particulars	Area (sq.m)	Volume (cu.m)	Remarks
01	Ground Floor	229.88	919.52	
02	First Floor	205.83	823.32	
03	Second Floor	205.83	823.32	
04	Total	641.54	2566.16	

**SCHEDULE OF JOINTS**

Sl. No.	Particulars	Area (sq.m)	Volume (cu.m)	Remarks
01	Ground Floor	229.88	919.52	
02	First Floor	205.83	823.32	
03	Second Floor	205.83	823.32	
04	Total	641.54	2566.16	

**Unit/In Table to Building A (RECCENTAN)**

Sl. No.	Particulars	Area (sq.m)	Volume (cu.m)	Remarks
01	Ground Floor	229.88	919.52	
02	First Floor	205.83	823.32	
03	Second Floor	205.83	823.32	
04	Total	641.54	2566.16	

**PROPOSED PLAN OF THREE STORED RESIDENTIAL BUILDING OF SAURAV KUMAR GUTGUTIA & HARSH KUMAR GUTGUTIA AT HOLDING NO.-00/00/00/00/00, PLOT NO.-53/54/1, KHATA NO.-60/15/5/0/1, J.L. NO.-06, THANA NO.-06, MOUZA-DHANDRA, WARD NO.-06, UNDERJAMTARA NAGAR PANCHAYAT.**

Sl. No.	Particulars	Area (sq.m)	Volume (cu.m)	Remarks
01	Ground Floor	229.88	919.52	
02	First Floor	205.83	823.32	
03	Second Floor	205.83	823.32	
04	Total	641.54	2566.16	

**COLOR INDEX**

Color	Material
Red	Concrete
Green	Plaster
Blue	Paint
Yellow	Paint

**PARKING CALCULATION**

Particulars	Area (sq.m)	Remarks
Proposed	100.00	
Required	100.00	
Balance	0.00	

**AREA STATEMENT**

Particulars	Area (sq.m)
TOTAL AREA OF LAND AREA	406.77
PROP. GROUND FLOOR COVER AREA	229.88
PROP. FIRST FLOOR COVER AREA	205.83
PROP. SECOND FLOOR COVER AREA	205.83
PROP. TOTAL COVER AREA	741.54
OPEN SPACE LEFT	466.79
HEIGHT FROM G.L. TO F.L.	4.00
TOTAL HEIGHT OF THE BUILDING	12.00
TOTAL STORED	THREE
NO. OF SEPTIC TANK	ONE
NO. OF TOILET	TEN
NO. OF STAIR CASE	ONE