

SITE PLAN

SITE PLAN

FAR & Tenement Details (Table 4c-1)

Building	No. of Same Bldg	Total Built Up Area (Sq.mt.)	Existing Built Up Area (Sq.mt.)	Proposed Built Up Area (Sq.mt.)	Existing FAR Area (Sq.mt.)	Proposed FAR Area (Sq.mt.)	Total FAR Area (Sq.mt.)	Total Consumed Additional FAR Area (Sq.mt.)	Tnmt (No.)
A (SRI JAYDIP JAYSAWAL)	1	228.74	114.37	114.37	114.37	114.37	228.74	228.74	01
Grand Total	1	228.74	114.37	114.37	114.37	114.37	228.74	228.74	01

Proposal Basic Information

Proposal File No.	LNPC/BP/0012/W01/2020
Owner Name	jaydip jaiswal
Khata No	28
Plot No	590,594
Village Name	Karkat
Use	Residential
SubUse	Bungalow/ Dwelling / Non Apartment

AREA STATEMENT LATEHAR NAGAR PANCHAYAT	VERSION NO. : 1.0.46
PROJECT DETAIL:	VERSION DATE: 22/06/2020
Region: JHARKHAND URBAN LOCAL BODIES	Plot Use: Residential
District: LATEHAR	Plot SubUse: Bungalow/ Dwelling / Non Apartment
Authority: LATEHAR NAGAR PANCHAYAT	PlotNearbyReligiousStructure: NA
Inward No: LNPCI/BP/0012/W01/2020	PlotSubPlot No: 590,594
Application Type: General Proposal	North: Road Width - 3.66
Project Type: Building Permission	South: Road Width - 9.14
Nature of Development: Addition or Alteration	East: Plot No. - satdev jaiswal
Location of Development Area: New Area	West: Plot No. - sanjay jaiswal
AREA DETAILS:	SQ.MT.
AREA OF PLOT (Minimum)	(A) 235.74
Deduction for NetPlot Area	
Surrender Free of Cost	14.82
Total	14.82
NET AREA OF PLOT(Gross Plot Area - Deduction from Gross Plot area)	(A-Deductions) 220.92
Deduction for Balance Plot Area(from Gross Plot Area)	
Surrender Free of Cost	14.82
Common Plot	51.45
Total	66.27
BALANCE AREA OF PLOT(Net Plot Area - Recreational/Amenity space)	(A-Deductions) 169.47
PLOT AREA FOR COVERAGE(Net Plot Area)	(A-Deductions) 220.92
Plot Area for FAR (Net Plot Area + RoadWidening Area)	(A-Deductions) 235.74
COVERAGE CHECK	
Permissible Coverage area (70.00 %)	154.64
Proposed Coverage Area (51.77 %)	114.37
Total Prop. Coverage Area (51.77 %)	114.37
Balance coverage area (18.23 %)	40.27
FAR CHECK	
Perm. FAR Area (1.50)	353.61
Total Perm. FAR area	353.61
Residential FAR	228.74
Proposed FAR Area	228.74
Total Proposed FAR Area	228.74
Consumed FAR (Factor)	0.97
Balance FAR Area	124.87
BUILT UP AREA CHECK	
Total Proposed BuiltUp Area	228.74
ARCHITECT (Regd)	law chaturvedi
ENGINEER (Regd)	
SUPERVISOR (Regd)	
OWNER (Regd)	jaydip jaiswal
DEVELOPMENT AUTHORITY	LOCAL BODY

COLOR INDEX	
PLOT BOUNDARY	Black
ABUTTING ROAD	Green
PROPOSED CONSTRUCTION	Red
COMMON PLOT	Yellow
ROAD WIDENING AREA	Blue
EXISTING (To be retained)	Orange
EXISTING (To be demolished)	Light Blue

Buildingwise Floor FAR Details

Floor Name	Building Name A (SRI JAYDIP JAYSAWAL)				Total			
	Proposed Built Up Area (Sq.mt.)	Existing Built up Area (Sq.mt.)	Proposed FAR Area (Sq.mt.)	Existing FAR (Sq.mt.)	Total Proposed Built up Area (Sq.mt.)	Total Existing Built up Area (Sq.mt.)	Total FAR Area (Sq.mt.)	Total Existing FAR Area (Sq.mt.)
Ground Floor	0.00	114.37	0.00	114.37	0.00	114.37	0.00	114.37
First Floor	114.37	0.00	114.37	0.00	114.37	0.00	114.37	0.00
Terrace Floor	0.00	0.00	0.00	0.00	0.00	0.00	0.00	0.00
Total	114.37	114.37	114.37	114.37	114.37	114.37	114.37	114.37

Building USE/SUBUSE Details

Building Name	Building Use	Building SubUse	Buildin
A (SRI JAYDIP JAYSAWAL)	Residential	Bungalow/ Dwelling / Non Apartment	

LTP NAME AND SIGNATURE law chaturvedi LNPCI/ENG/0004/2018	STRUCTURAL ENG'S NAME AND SIGNATURE	BUILDER NAME AND SIGNATURE	DATE OF ISSUE 25/07/2020 Designation : Executive Officer Organization : Personal
---	-------------------------------------	----------------------------	---

Proposal Basic Information	
Proposal File No.	LNPC/BI/0012/W01/2020
Owner Name	Jaydip Jaiswal
Khata No	28
Plot No	590,594
Village Name	Karkat
Use	Residential
SubUse	Bungalow/ Dwelling / Non Apartment

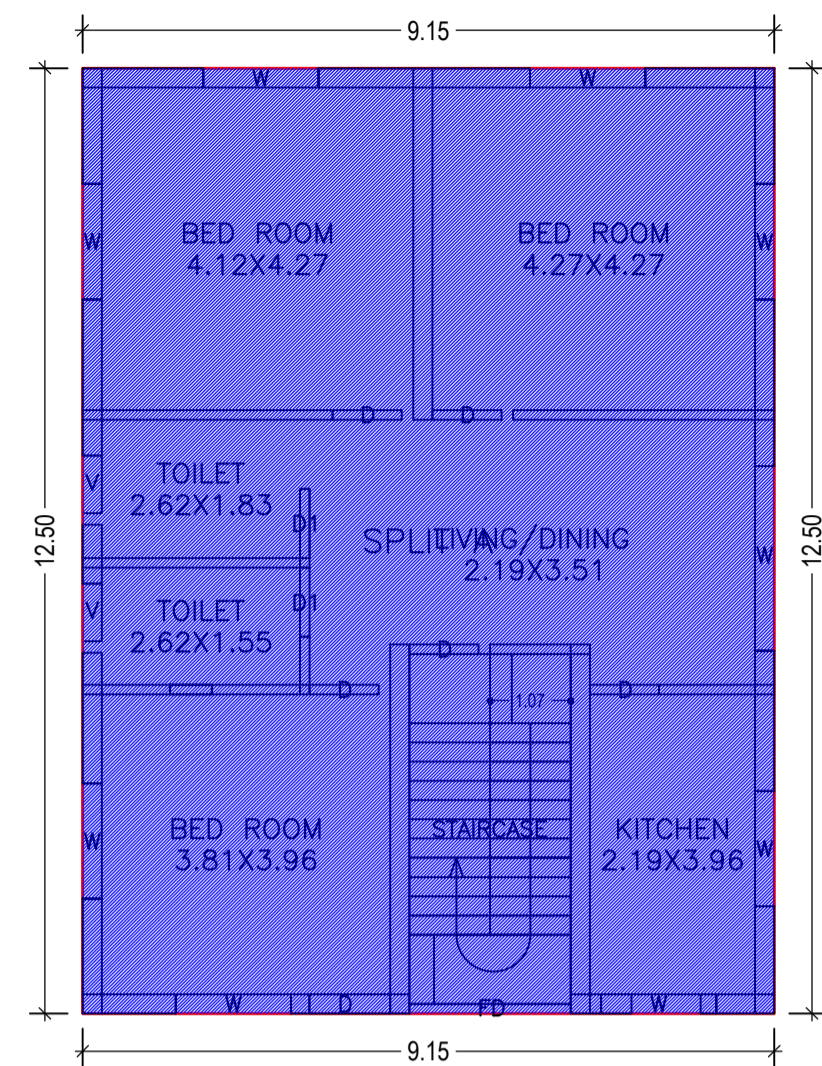

GROUND FLOOR PLAN (Existing) (SCALE 1:100)

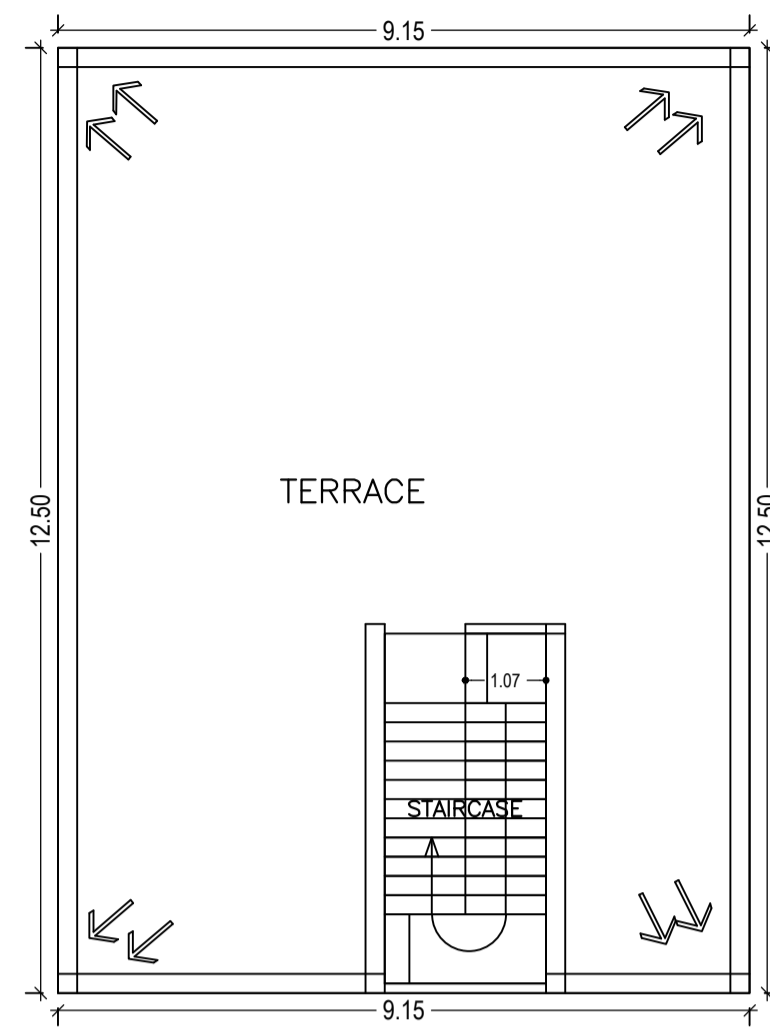

TERRACE FLOOR PLAN (SCALE 1:100)

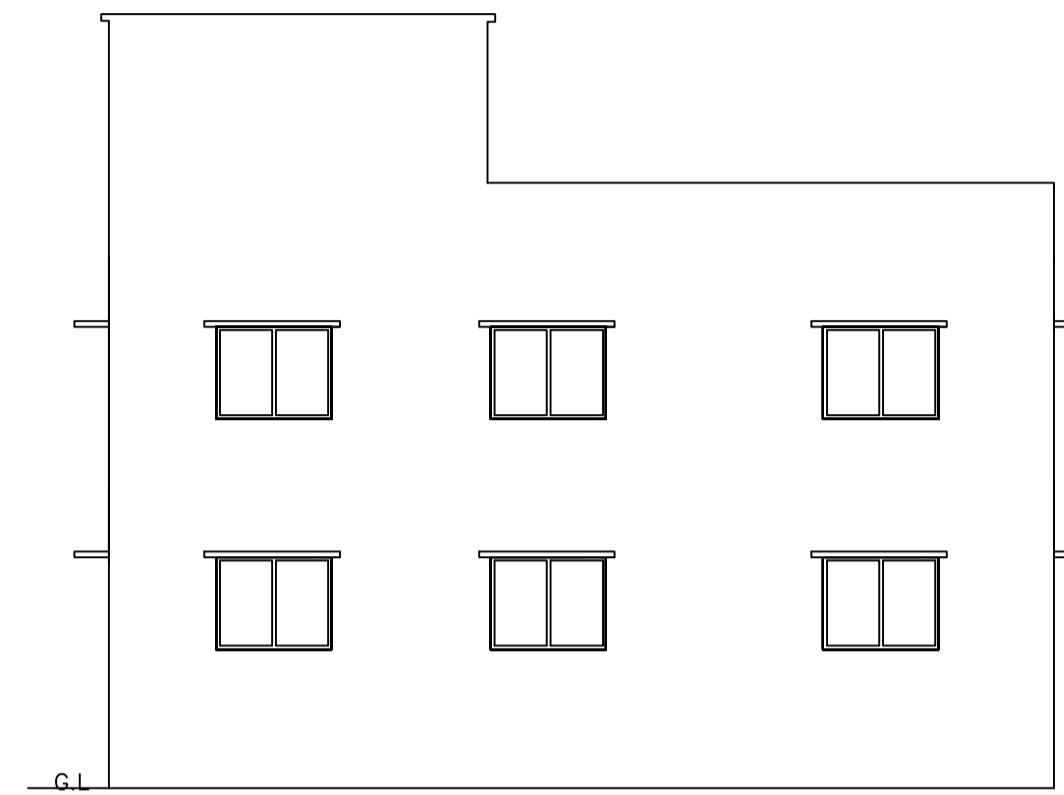

EAST SIDE ELEVATION

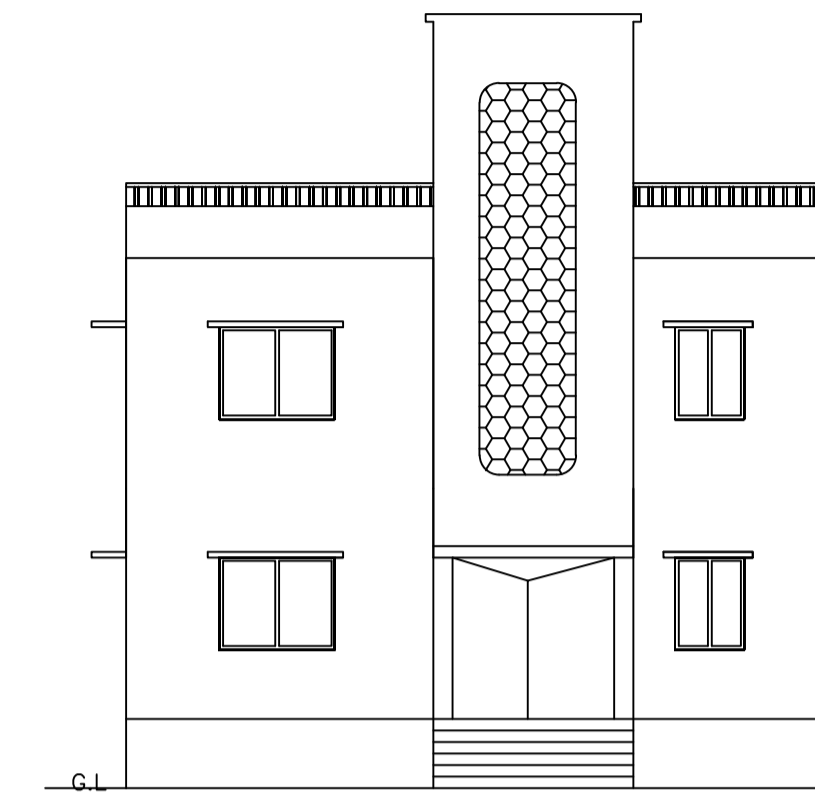

FRONT SIDE ELEVATION

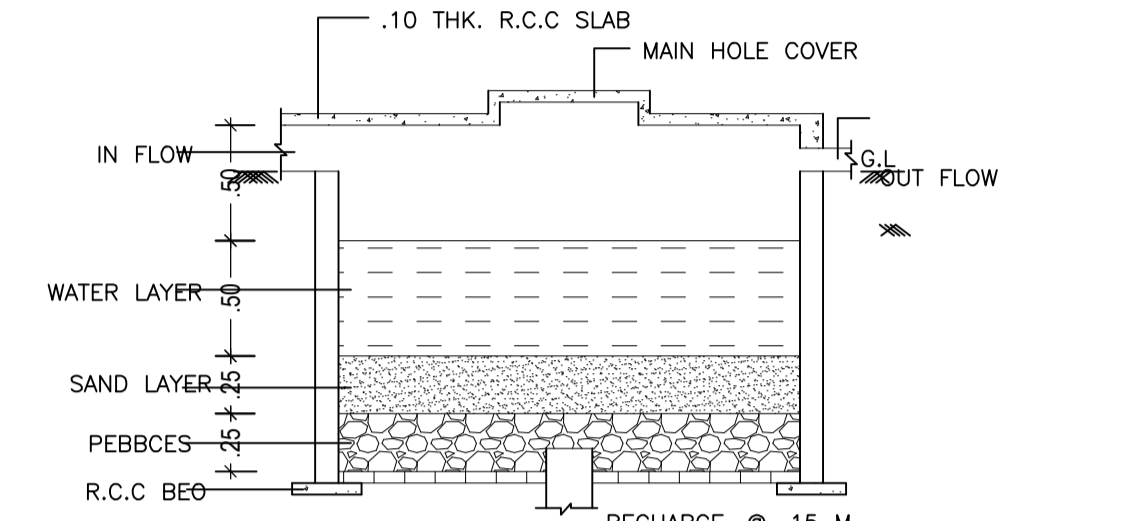

DETAIL OF RAIN WATER HARVESTING AND RECHARGE PIT.(N.T.S)

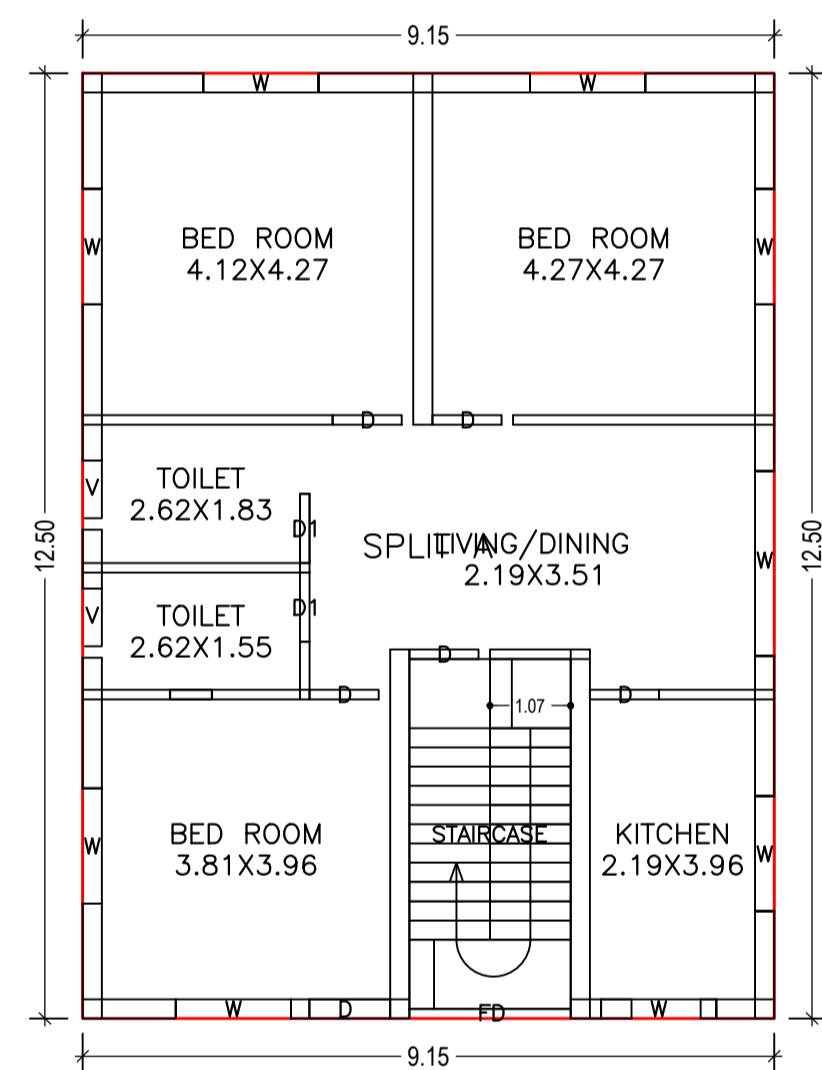

FIRST FLOOR PLAN (Proposed) (SCALE 1:100)

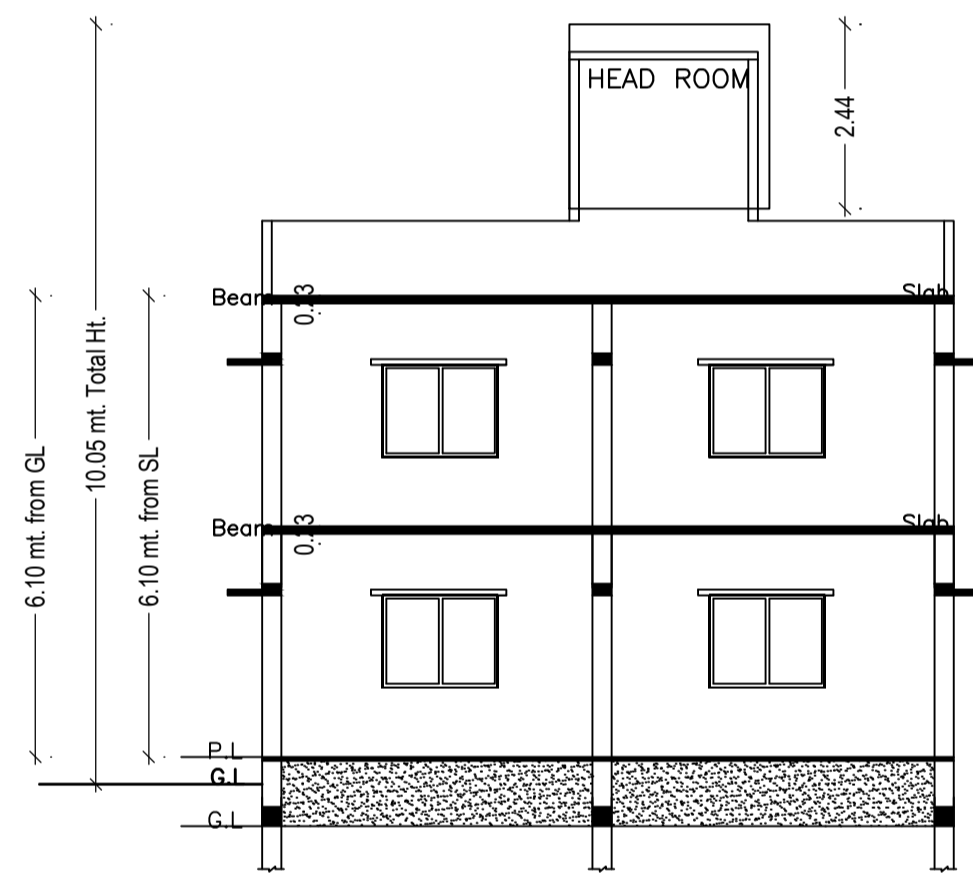

SECTION - BB

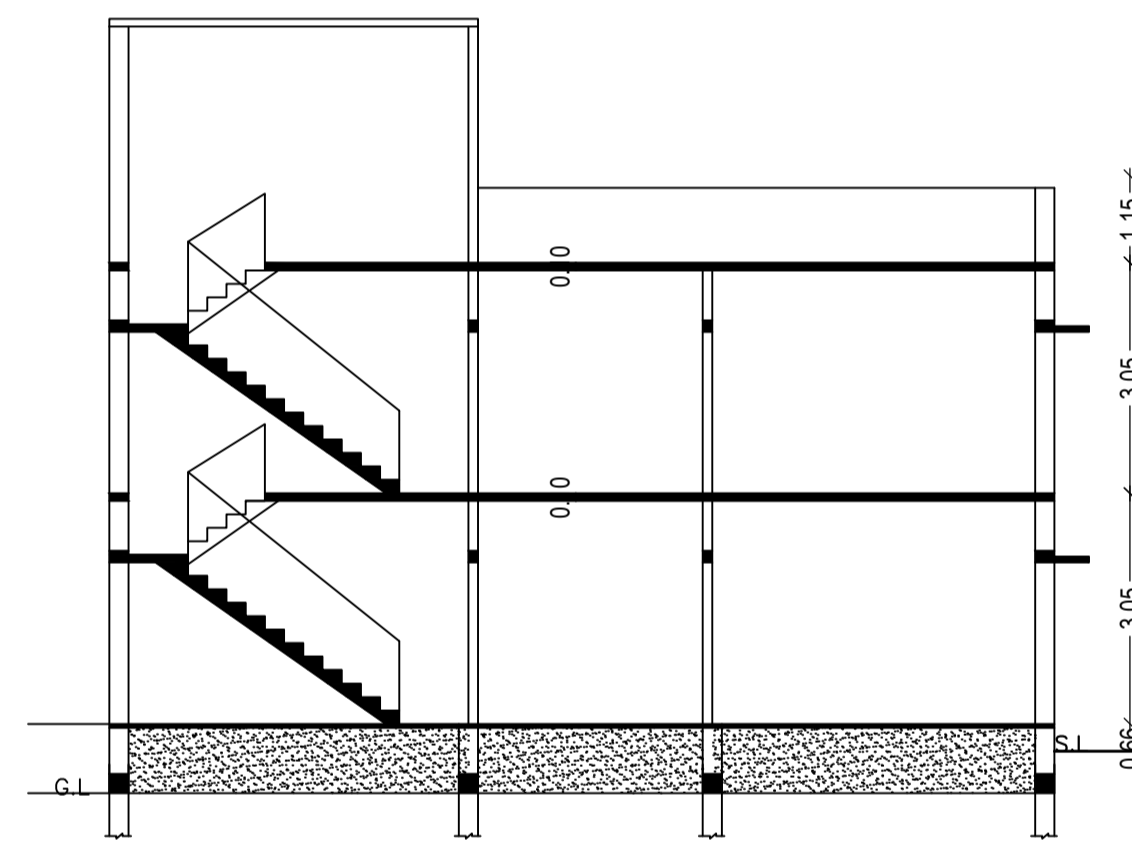

SECTION - AA

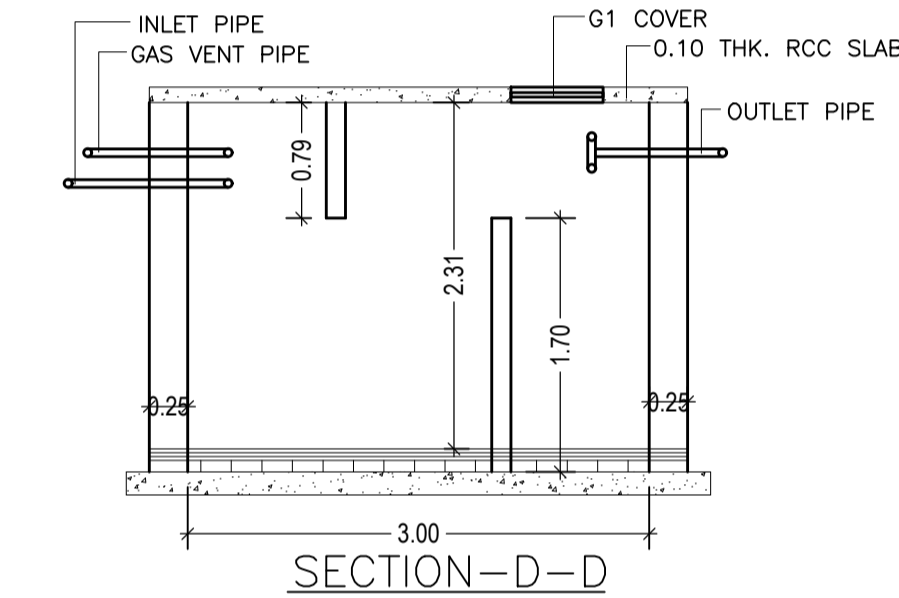

SECTION - D-D

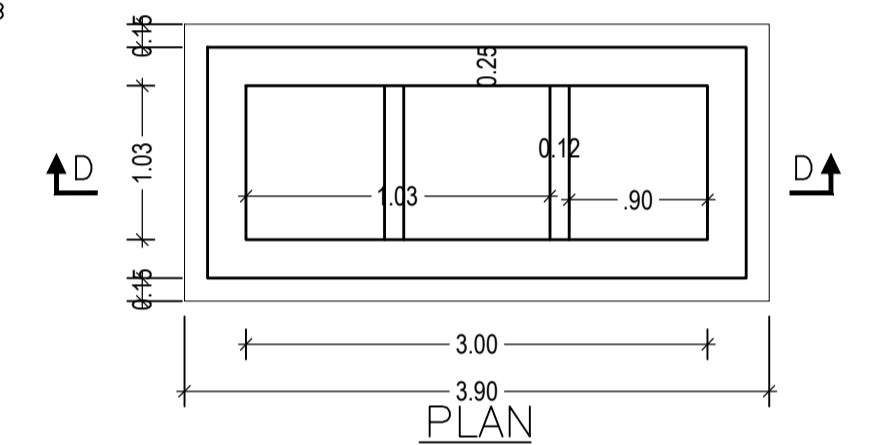

DETAIL OF SEPTIC TANK.

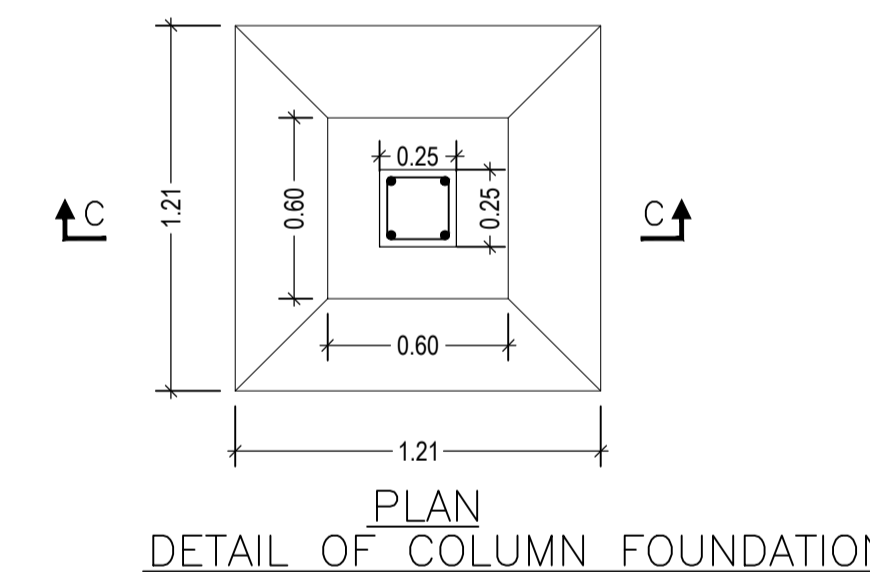

DETAIL OF COLUMN FOUNDATION

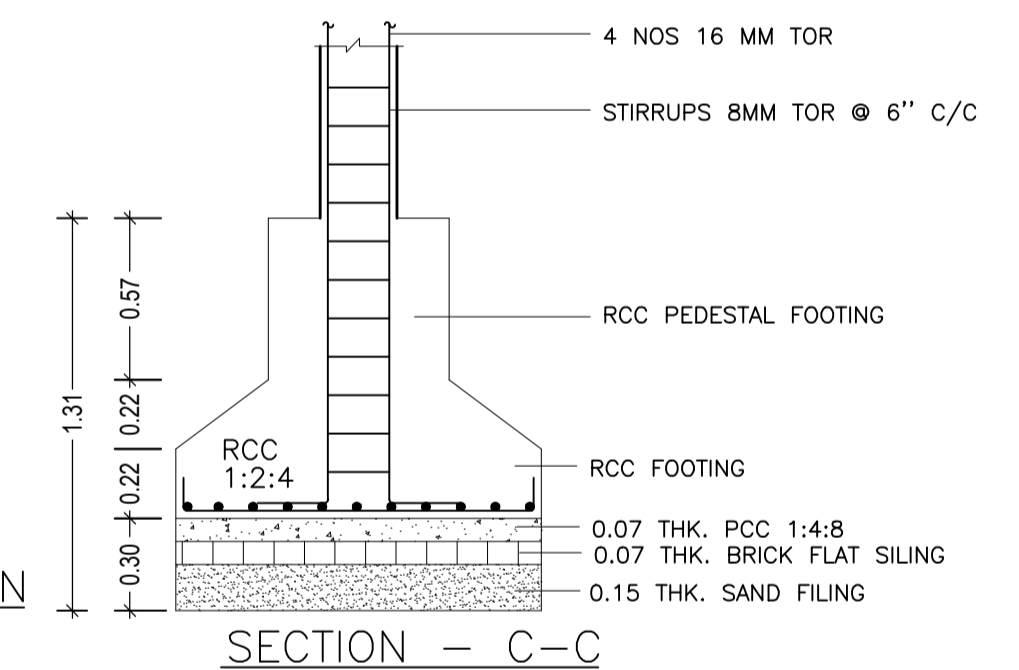

SECTION - C-C

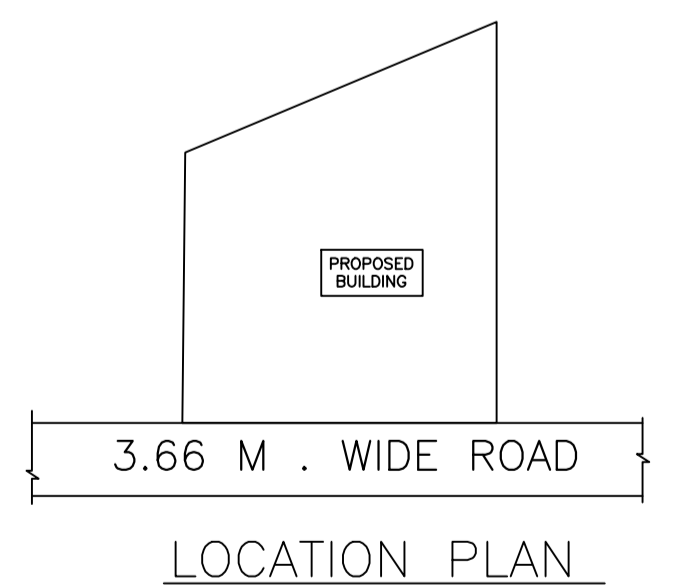

LOCATION PLAN

Building :A (SRI JAYDIP JAYSAWAL)

Floor Name	Total Built Up Area (Sq.mt.)	Existing Built Up Area (Sq.mt.)	Proposed Built Up Area (Sq.mt.)	Existing FAR Area (Sq.mt.)	Proposed FAR Area (Sq.mt.)	Total FAR Area (Sq.mt.)	Total Consumed Additional FAR Area (Sq.mt.)	Tnmt (No.)
Ground Floor	114.37	114.37	0.00	114.37	0.00	114.37	114.37	01
First Floor	114.37	0.00	114.37	0.00	114.37	114.37	114.37	00
Terrace Floor	0.00	0.00	0.00	0.00	0.00	0.00	0.00	00
Total :	228.74	114.37	114.37	114.37	114.37	228.74	228.74	01
Total Number of Same Buildings	1							
Total :	228.74	114.37	114.37	114.37	114.37	228.74	228.74	01

SCHEDULE OF DOOR:

BUILDING NAME	NAME	LENGTH	HEIGHT	NOS
A (SRI JAYDIP JAYSAWAL)	D	0.91	2.10	10
A (SRI JAYDIP JAYSAWAL)	D1	0.91	2.10	04
A (SRI JAYDIP JAYSAWAL)	D	1.07	2.10	02

SCHEDULE OF WINDOW/VENTILATION:

BUILDING NAME	NAME	LENGTH	HEIGHT	NOS
A (SRI JAYDIP JAYSAWAL)	V	0.76	1.20	04
A (SRI JAYDIP JAYSAWAL)	W	1.52	1.20	16
A (SRI JAYDIP JAYSAWAL)	W	2.44	1.20	02

UnitBUA Table for Building :A (SRI JAYDIP JAYSAWAL)

FLOOR	Name	UnitBUA Type	Entity Type	UnitBUA Area	Carpet Area	No. of Rooms	No. of Tenement
GROUND FLOOR PLAN	SPLIT A	FLAT	Existing	182.80	182.66	7	1
FIRST FLOOR PLAN	SPLIT A	FLAT	Proposed	0.00	0.00	7	0
Total:	-	-	-	182.80	182.66	14	1

LTP NAME AND SIGNATURE	STRUCTURAL ENG'S NAME AND SIGNATURE	BUILDER NAME AND SIGNATURE	DATE OF SIGNATURE
law chaturvedi LNPC/ENG/0004/2018			25-07-2020

Proposal Basic Information	
Proposal File No.	LNPC/BP/0012/W01/2020
Owner Name	jaydip jaiswal
Khata No	28
Plot No	590,594
Village Name	Karkat
Use	Residential
SubUse	Bungalow/ Dwelling / Non Apartment

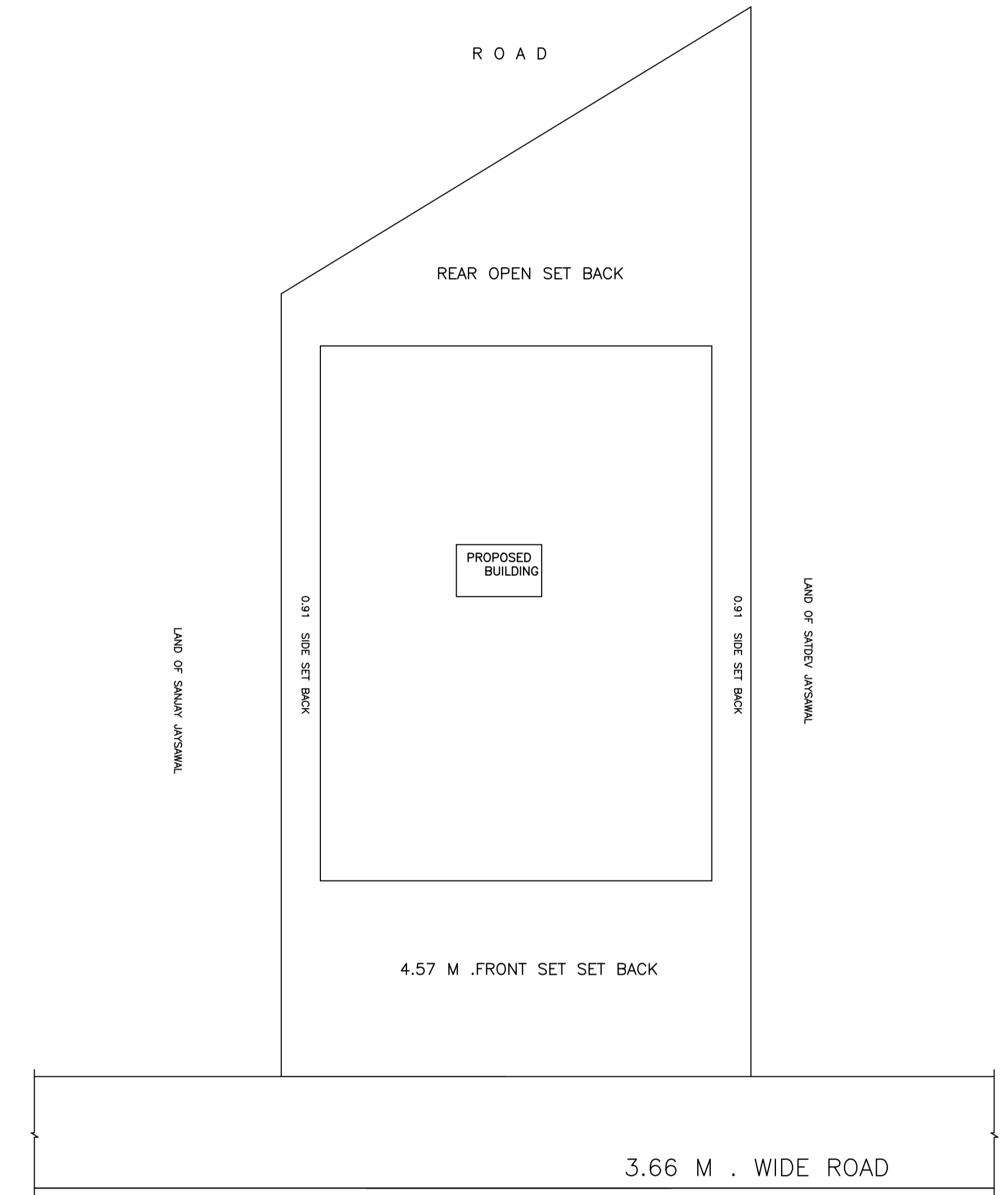

SITE PLAN

LTP NAME AND SIGNATURE	STRUCTURAL ENG'S NAME AND SIGNATURE	BUILDER NAME AND SIGNATURE	NAME AND SIGNATURE
law chaturvedi LNPC/ENG/0004/2018			Signature : Executive Officer Organization : Personal