

Project Title :SMT VANDANA KUMARI

AREA STATEMENT: LATEHAR (JHARKHAND)	VERSION NO.: 1.0
PROJECT NAME: SMT Vandana Kumari	DESIGN DATE: 16/05/2024
CLIENT: SMT Vandana Kumari	PROJECT TYPE: Residential Building
APPLICATOR: SMT Vandana Kumari	ACTING: SMT Vandana Kumari
PROJECT TYPE: Residential Building	PLAN NO.: 1/2024
STATUS: Approved	APPROVAL: SMT Vandana Kumari
LOCALITY: SMT Vandana Kumari	WILL NO.: 1/2024
WILL NO.: 1/2024	WILL DATE: 16/05/2024
WILL AREA: 321.61 sqm	WILL NO.: 1/2024
WILL DATE: 16/05/2024	WILL NO.: 1/2024

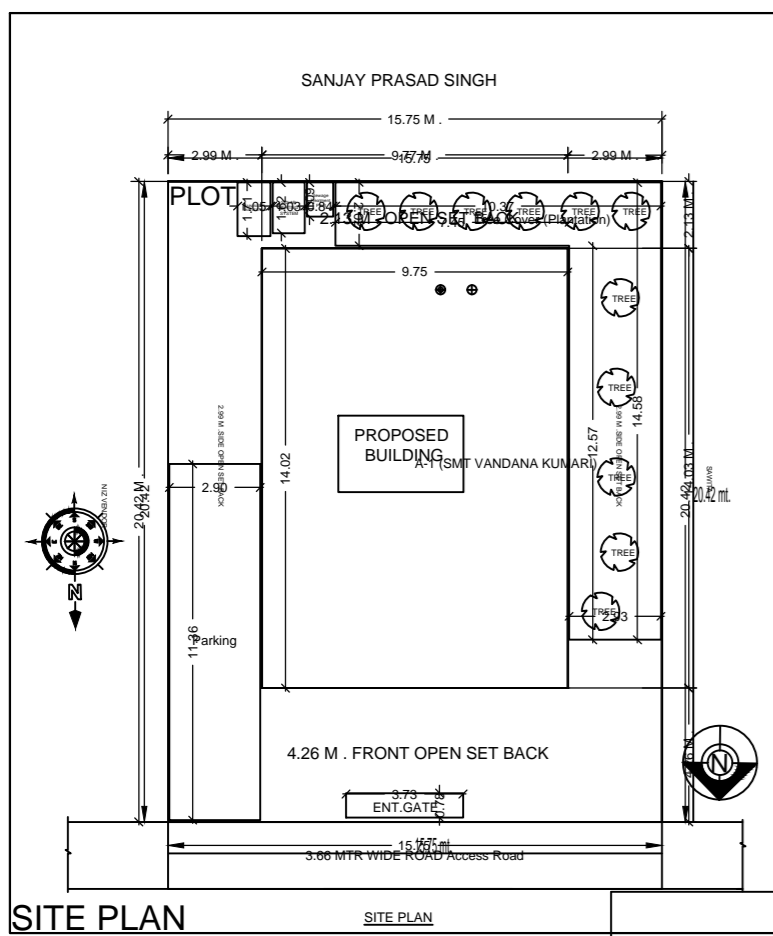
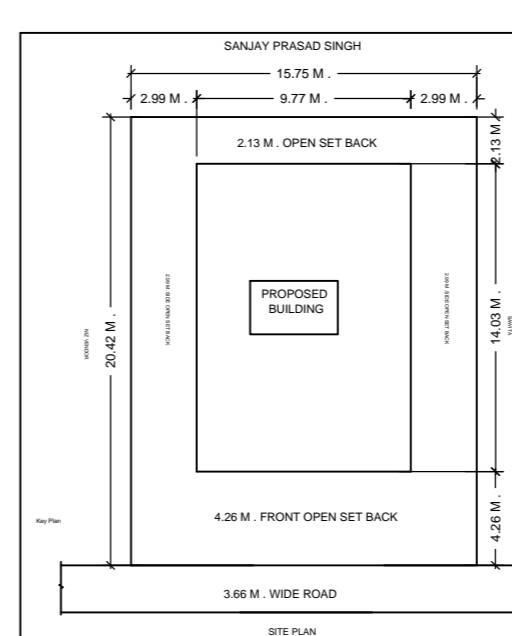
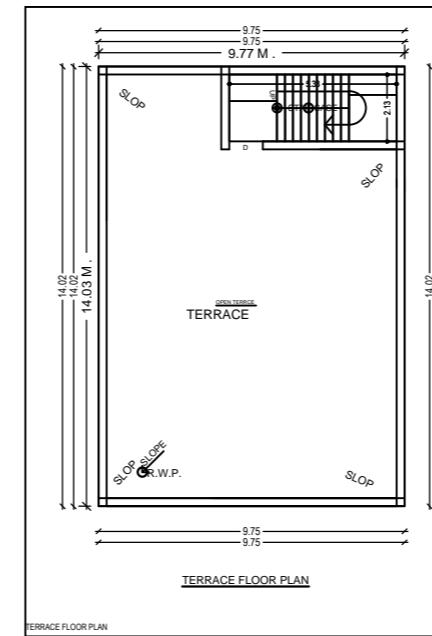
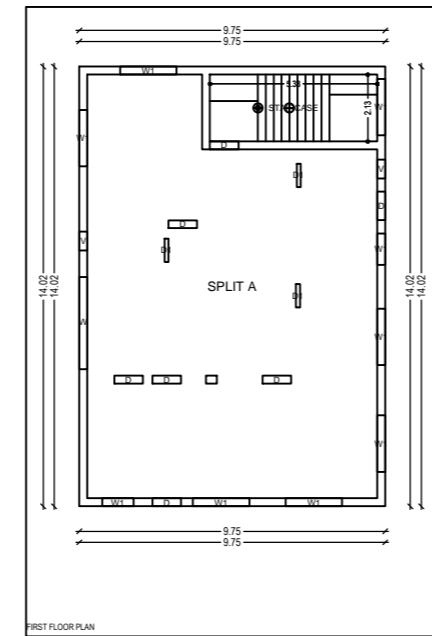
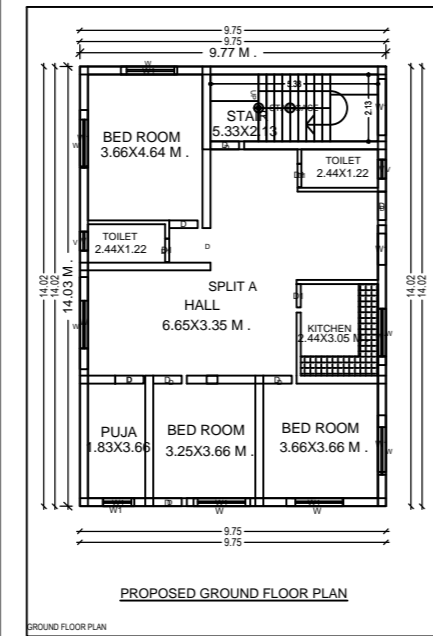
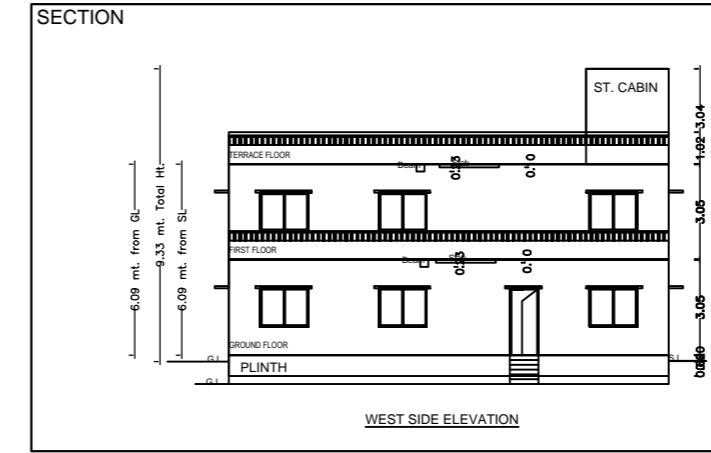
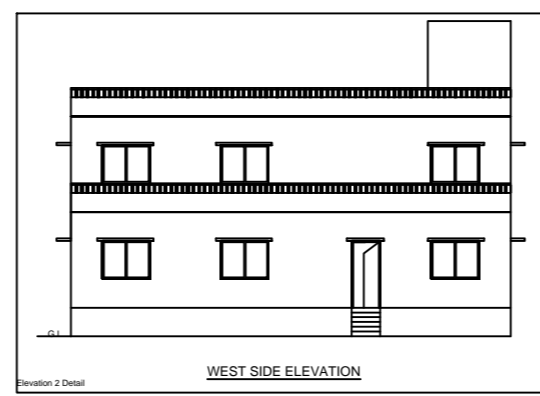
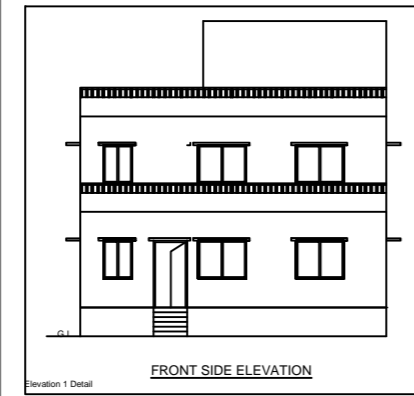

SIZE	REMARK
D	1.00X2.13 F PANELED
D1	0.79X2.13 F PANELED
W	1.82X1.21 F GLAZED
V	1.82X0.30 F GLAZED
W1	0.91X1.21 F GLAZED
V1	0.91X0.30 F GLAZED

- SPECIFICATION**
- FOUNDATION R.C.C COLUMN FOUNDATION IN 1:2:4 AS PER DETAIL.
 - S. STRUCTURE 1ST CLASS BRICK WORK IN CM 1:6 IN PLINTH CM 1:8 IN S. STRUCTURE.
 - R.C.C LINTEL BAND ROOF SLAB IN 1:2:4.
 - PLASTERING - 0.03 TH CM WALL IN 1:6 & 1:4 TH CEMENT PLASTER ON CEILING 1:4.
 - FLOORING - 0.03 TH PS FLOOR OR MARBALE FLOOR OVER 0.11 TH DRY RAMED KHOA OVER BRICK FLAT SOLING.
 - 0.11 TH AVELUME CONCRETE 0.11 R.C.C SLAB.
 - FLOORING AND DADO-MOSAIC OR TILES
 - TOILETS PVC PIPE FITTING WITH PARRY WARE SANITARY FITTING.
 - FINISHING LIME WASH DISTEMPER ON INTERNAL SURFACE SNOWCEN OVER EXTERNAL SYNTHETIC ENAMEL PAINT OVER WOOD AND STEEL WORK.

AREA DETAILS	UNIT	QUANTITY
NET PLOT AREA	Sqm	321.61
NET PLOT AREA (Gross Plot Area)	(A-Deductions)	321.61
Deductions for Balance Plot Area (from Gross Plot Area)		
G.P. Area		321.61
Net		321.61
Balance Plot Area (Net Plot Area)	(A-Deductions)	321.61
Plot Area for Coverage (Net Plot Area)	(A-Deductions)	321.61
Plot Area for FSI (Net Plot Area)	(A-Deductions)	321.61
Flooring Area		321.61
COVERED CHECK:		
Proposed Coverage Area (42.50 %)		136.68
Total Coverage Area (42.50 %)		136.68
PROPOSED:		
Proposed Area of FAR		273.90
Total Area of FAR		273.90
NET PROPOSED BUILDING AREA		273.90
NET PLOT AREA (GROSS PLOT AREA)		321.61
COVERED AREA		136.68
UNCOVERED AREA		184.93
DEVELOPMENT AUTHORITY		LOCAL BODY

PLASTER	White
CEILING	White
FLOORING	As per specification
TOILETS	White
WALLS	White
ROOFING	As per specification

Category	Prop. No.	Plot Area
Other Parking		321.61
Parking	1	321.61

Category	Front Margin	Rear Margin	Side Margin	Sidewalk Margin
Proposed Building	2.13	2.13	3.00	3.00

Building	No. of Same Bldg	Total Built Up Area (sq.m)	Existing Built Up Area (sq.m)	Proposed Built Up Area (sq.m)	Existing FAR (sq.m/1000 sq.m)	Proposed FAR (sq.m/1000 sq.m)	Total FAR	Zone (No.)
1/2024 (SMT VANDANA KUMARI)	1	273.90	136.68	136.68	136.68	273.90	273.90	01

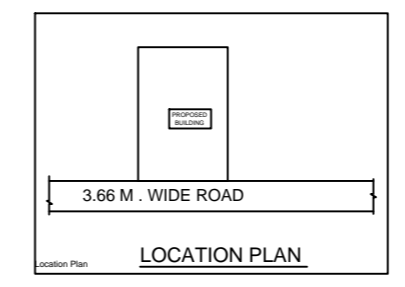
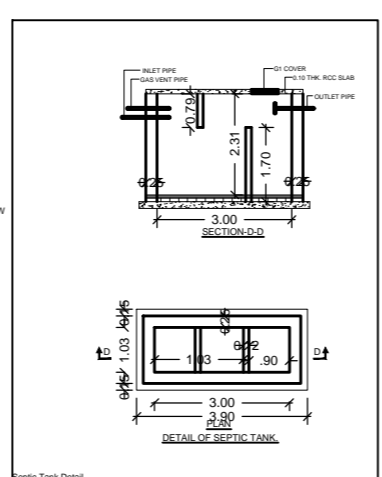
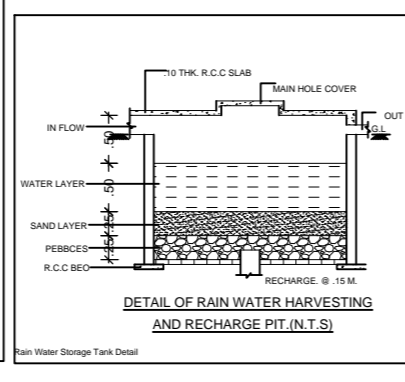
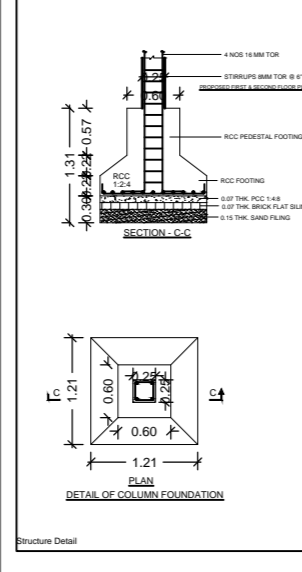

MAP APPROVED BY

SIGNATURE OF APPLICANT

SIGNATURE OF ENGINEER

Floor Name	Total Built Up Area (Sq.m)	Existing Built Up Area (Sq.m)	Proposed Built Up Area (Sq.m)	Existing FAR Area (Sq.m)	Proposed FAR Area (Sq.m)	Total FAR Area (Sq.m)	Zone (No.)
GROUND FLOOR	136.75	136.75	0.00	136.75	0.00	136.75	01
FIRST FLOOR	136.75	0.00	136.75	0.00	136.75	136.75	00
TERACE	0.00	0.00	11.30	0.00	0.00	0.00	00
TOTAL	273.50	136.75	148.13	136.75	136.75	273.50	01

MEMBER NAME	NAME	LENGTH	HEIGHT	NO.
A SMT VANDANA KUMARI	D1	0.75	2.13	06
A SMT VANDANA KUMARI	D	0.91	2.13	14
A SMT VANDANA KUMARI	W	-	-	26

MEMBER NAME	NAME	LENGTH	HEIGHT	NO.
A SMT VANDANA KUMARI	V	0.80	1.00	04
A SMT VANDANA KUMARI	W1	1.00	2.70	04
A SMT VANDANA KUMARI	W1	1.80	2.70	14
A SMT VANDANA KUMARI	W	2.13	2.70	02
A SMT VANDANA KUMARI	V1	-	-	24

FLOOR	Name	UnBIA Type	Entry Type	UnBIA Area	Carpet Area	No. of Rooms	No. of Tenement
GROUND FLOOR	SPLIT A	-	Existing	223.15	223.91	8	1
TERR	-	-	-	223.15	223.91	16	1