

Required Parking (Table 7a)

Building Name	Type	SubUse	Area (Sq.mt.)	Car		Visitors Car		TwoWheeler	
				Reqd.	Prop.	Reqd./Unit	Prop./Unit	Reqd./Unit	Prop./Unit
PRADEEP (UPADHYAY)	Residential	Residential Apartment Bldg	> 0	1	1.00	1	1	-	-
			> 0	8	-	-	-	-	-
			> 0	1	1.00	-	-	1	1
			> 0	8	-	-	-	2	4
Total :									

Building : PRADEEP (UPADHYAY)

Floor Name	Total Built Up Area (Sq.mt.)	Proposed FAR Area (Sq.mt.)	Total FAR Area (Sq.mt.)	Total Consumed Additional FAR Area (Sq.mt.)	Tnmt (No.)
Ground Floor	427.97	0.00	427.97	427.97	01
First Floor	427.97	427.97	427.97	427.97	01
Terrace Floor	0.00	0.00	0.00	0.00	00
Total :	855.94	427.97	855.94	855.94	02

SCHEDULE OF DOOR:

BUILDING NAME	NAME	LENGTH	HEIGHT	NOS
PRADEEP (UPADHYAY)	D1	0.91	2.10	17
PRADEEP (UPADHYAY)	D1	1.04	2.10	02
PRADEEP (UPADHYAY)	D	1.07	2.10	17
PRADEEP (UPADHYAY)	D	1.52	2.10	02
PRADEEP (UPADHYAY)	RS	2.78	2.10	01
PRADEEP (UPADHYAY)	RS	2.79	2.10	01
PRADEEP (UPADHYAY)	RS	2.92	2.10	01
PRADEEP (UPADHYAY)	RS	2.93	2.10	01
PRADEEP (UPADHYAY)	RS	3.05	2.10	09
PRADEEP (UPADHYAY)	RS	3.17	2.10	01

SCHEDULE OF WINDOW/VENTILATION:

BUILDING NAME	NAME	LENGTH	HEIGHT	NOS
PRADEEP (UPADHYAY)	V1	0.30	1.20	03
PRADEEP (UPADHYAY)	W7	0.46	1.20	01
PRADEEP (UPADHYAY)	W8	0.51	1.20	01
PRADEEP (UPADHYAY)	W1	0.91	1.20	10
PRADEEP (UPADHYAY)	W	0.91	1.20	01
PRADEEP (UPADHYAY)	W9	1.01	1.20	01
PRADEEP (UPADHYAY)	W10	1.18	1.20	01
PRADEEP (UPADHYAY)	W	1.52	1.20	15
PRADEEP (UPADHYAY)	W1	1.70	1.20	02

Unit/BUA Table for Building : PRADEEP (UPADHYAY)

FLOOR	Name	Unit/BUA Type	Unit/BUA Area	Carpet Area	No. of Rooms	No. of Tenement
GROUND FLOOR	CFAR-47	SHOP	385.22	378.20	16	1
FIRST FLOOR	SPLIT A	FLAT	385.22	369.61	38	1
Total:			770.44	747.81	54	2

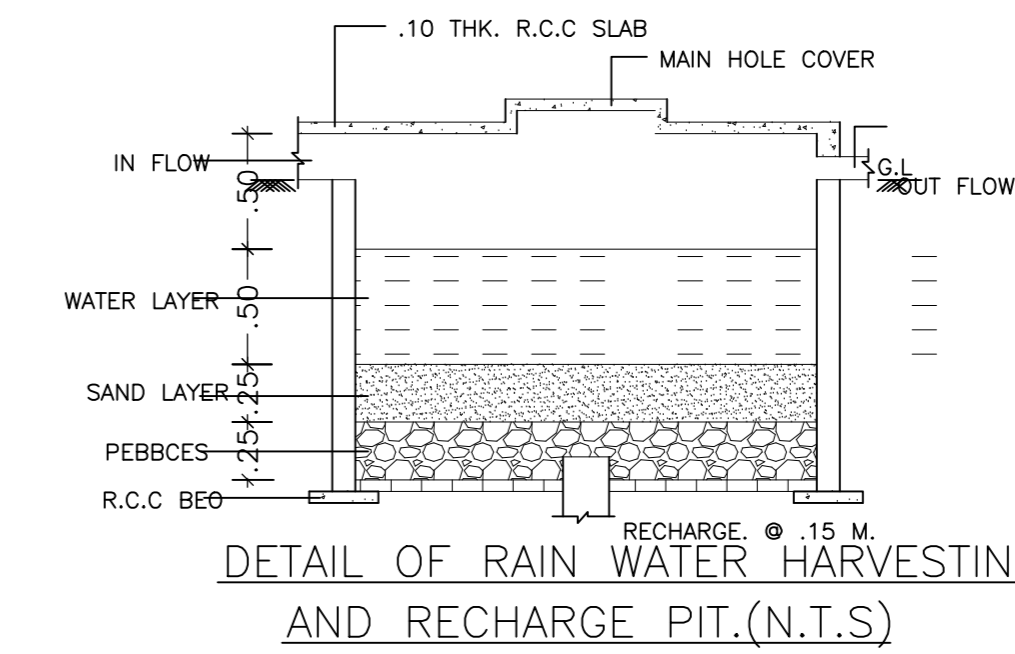

Proposal Basic Information

Proposal File No	LNPC/BP/0024/W10/2020
Owner Name	PRADEEP KUMAR UPADHYAY
Khata No	18
Plot No	536
Village Name	Banpur
Use	Commercial
SubUse	Commercial Bldg

AREA STATEMENT LATEHAR NAGAR PANCHAYAT	VERSION NO. : 1.0.50	VERSION DATE: 16/10/2020
PROJECT DETAIL:	Plot Use: Commercial	
Region: JHARKHAND URBAN LOCAL BODIES	Plot SubUse: Commercial Bldg	
District: LATEHAR	PlotNearby/ReligiousStructure: NA	
Authority: LATEHAR NAGAR PANCHAYAT		
Inward No: LNPC/BP/0024/W10/2020	Plot/SubPlot No: 536	
Application Type: General Proposal	North: Plot No. - OTHER PLOT	
Project Type: Building Permission	South: Plot No. - OTHER PLOT	
Nature of Development: New	East: Plot No. - OTHER PLOT	
Location of Development Area: Old Area	West: Road Width - ROAD	
AREA DETAILS:		SQ.MT.
AREA OF PLOT (Minimum)	(A)	1281.25
NET AREA OF PLOT (Gross Plot Area - Deduction from Gross Plot area)	(A-Deductions)	1281.25
Deduction for Balance Plot Area (from Gross Plot Area)		
Common Plot		112.60
Total		112.60
BALANCE AREA OF PLOT (Net Plot Area - Deduction from Gross Plot area)	(A-Deductions)	1168.64
Recreational/Amenity space		
PLOT AREA FOR COVERAGE (Net Plot Area)	(A-Deductions)	1281.25
Plot Area for FAR (Net Plot Area + Road Widening Area)	(A-Deductions)	1281.25
COVERAGE CHECK		
Permissible Coverage area (50.00 %)		640.63
Proposed Coverage Area (33.40 %)		427.97
Total Prop. Coverage Area (33.4 %)		427.97
Balance coverage area (16.60 %)		212.66
FAR CHECK		
Perm. FAR Area (2.00)		2562.50
Total Perm. FAR area		2562.50
Residential FAR		427.97
Commercial FAR		427.97
Proposed FAR Area		855.94
Total Proposed FAR Area		855.94
Consumed FAR (Factor)		0.67
Balance FAR Area		1706.56
BUILT UP AREA CHECK		
Total Proposed BuiltUp Area		855.94
ARCHITECT (Regd)		law_chaturvedi
ENGINEER (Regd)		
SUPERVISOR (Regd)		PRADEEP KUMAR UPADHYAY
OWNER (Regd)		
DEVELOPMENT AUTHORITY		LOCAL BODY

COLOR INDEX	
PLOT BOUNDARY	Black
ABUTTING ROAD	Green
PROPOSED CONSTRUCTION	Red
COMMON PLOT	Yellow
ROAD WIDENING AREA	Blue
EXISTING (To be retained)	Light Blue
EXISTING (To be demolished)	Light Yellow

Buildingwise Floor FAR Details

Floor Name	Building Name PRADEEP (UPADHYAY)		Total	
	Proposed Built Up Area (Sq.mt.)	Proposed FAR Area (Sq.mt.)	Total Proposed Built Up Area (Sq.mt.)	Total FAR Area (Sq.mt.)
Ground Floor	427.97	427.97	427.97	427.97
First Floor	427.97	427.97	427.97	427.97
Terrace Floor	0.00	0.00	0.00	0.00
Total :	855.94	855.94	855.94	855.94

Building USE/SUBUSE Details

Building Name	Building Use	Building SubUse	Building Structure
PRADEEP (UPADHYAY)	Commercial	Commercial Bldg	Non-Highrise

Parking Check (Table 7b)

Vehicle Type	Reqd.		Prop.	
	No.	Area	No.	Area
Car	-	-	6	75.00
Total Car	2	25.00	6	75.00
Visitor's Car Parking	-	-	4	50.00
Total Visitor Parking	2	25.00	4	50.00
TwoWheeler	-	-	18	36.00
Total TwoWheeler	1	2.00	18	36.00
Total		52.00		197.00

FAR & Tenement Details (Table 4c-1)

Building	No. of Same Bldg	Total Built Up Area (Sq.mt.)	Proposed FAR Area (Sq.mt.)	Total FAR Area (Sq.mt.)	Total Consumed Additional FAR Area (Sq.mt.)	Tnmt (No.)
PRADEEP (UPADHYAY)	1	855.94	427.97	855.94	855.94	02
Grand Total	1	855.94	427.97	855.94	855.94	02

