

SITE PLAN SITE PLAN

FAR & Tenement Details (Table 4c-1)

Building	No. of Same Bldg	Total Built Up Area (Sq.mt.)	Proposed FAR Area (Sq.mt.) Resi.	Total FAR Area (Sq.mt.)	Total Consumed Additional FAR Area (Sq.mt.)	Tnmt (No.)
A (A1)	1	161.64	161.64	161.64	161.64	01
Grand Total :	1	161.64	161.64	161.64	161.64	01

Proposal Basic Information

Proposal File No.	LNPC/BP/0018/W11/2020
Owner Name	PRIYA SINGH
Khata No	46
Plot No	254
Village Name	Latehar
Use	Residential
SubUse	Bungalow/ Dwelling / Non Apartment

AREA STATEMENT LATEHAR NAGAR PANCHAYAT		VERSION NO.: 1.0.49
PROJECT DETAIL:		VERSION DATE: 22/06/2020
Region: JHARKHAND URBAN LOCAL BODIES	Plot Use: Residential	
District: LATEHAR	Plot SubUse: Bungalow/ Dwelling / Non Apartment	
Authority: LATEHAR NAGAR PANCHAYAT	PlotNearbyReligiousStructure: NA	
Inward_No: LNPCI/BP/0018/W11/2020	PlotSubPlot No: 254	
Application Type: General Proposal	North: Plot No. - RINKI DEVI	
Project Type: Building Permission	South: Plot No. - MADHU KUMARI	
Nature of Development: New	East: Plot No. - ROAD	
Location of Development Area: Old Area	West: Plot No. - 253	
AREA DETAILS:		
AREA OF PLOT (Minimum)	(A)	SQ.MT. 141.57
NET AREA OF PLOT(Gross Plot Area - Deduction from Gross Plot area)	(A-Deductions)	141.57
Deduction for Balance Plot Area(from Gross Plot Area)		
Common Plot		9.56
Total		9.56
BALANCE AREA OF PLOT(Net Plot Area - Recreational/Amenity space)	(A-Deductions)	132.01
PLOT AREA FOR COVERAGE(Net Plot Area)	(A-Deductions)	141.57
Plot Area for FAR (Net Plot Area + RoadWidening Area)	(A-Deductions)	141.57
COVERAGE CHECK		
Permissible Coverage area (70.00 %)		99.10
Proposed Coverage Area (57.09 %)		80.82
Total Prop. Coverage Area (57.09 %)		80.82
Balance coverage area (12.91 %)		18.28
FAR CHECK		
Perm. FAR Area (1.50)		212.36
Total Perm. FAR area		212.36
Residential FAR		161.64
Proposed FAR Area		161.64
Total Proposed FAR Area		161.64
Consumed FAR (Factor)		1.14
Balance FAR Area		50.72
BUILT UP AREA CHECK		
Total Proposed BuiltUp Area		161.64
ARCHITECT (Regd)	law chaturvedi	
ENGINEER (Regd)		
SUPERVISOR (Regd)		
OWNER (Regd)	PRIYA SINGH	
DEVELOPMENT AUTHORITY		LOCAL BODY

COLOR INDEX	
PLOT BOUNDARY	Black
ABUTTING ROAD	Green
PROPOSED CONSTRUCTION	Red
COMMON PLOT	Yellow
ROAD WIDENING AREA	Blue
EXISTING (To be retained)	Light Blue
EXISTING (To be demolished)	Light Yellow

Buildingwise Floor FAR Details

Floor Name	Building Name A (A1)		Total	
	Proposed Built Up Area (Sq.mt.)	Proposed FAR Area (Sq.mt.)	Total Proposed Built Up Area (Sq.mt.)	Total FAR Area (Sq.mt.)
Ground Floor	80.82	80.82	80.82	80.82
First Floor	80.82	80.82	80.82	80.82
Terrace Floor	0.00	0.00	0.00	0.00
Total :	161.64	161.64	161.64	161.64

Building USE/SUBUSE Details

Building Name	Building Use	Building SubUse	Building Structure
A (A1)	Residential	Residential Bldg/Apartment	Non-Highrise

LTP NAME AND SIGNATURE	STRUCTURAL ENG'S NAME AND SIGNATURE	BUILDER NAME AND SIGNATURE	DIGITAL SIGNATURE
law chaturvedi LNPCI/ENG/0004/2018			

Proposal Basic Information	
Proposal File No.	LNPC/BP/0018/W11/2020
Owner Name	PRIYA SINGH
Khata No	46
Plot No	254
Village Name	Latehar
Use	Residential
SubUse	Bungalow/ Dwelling / Non Apartment

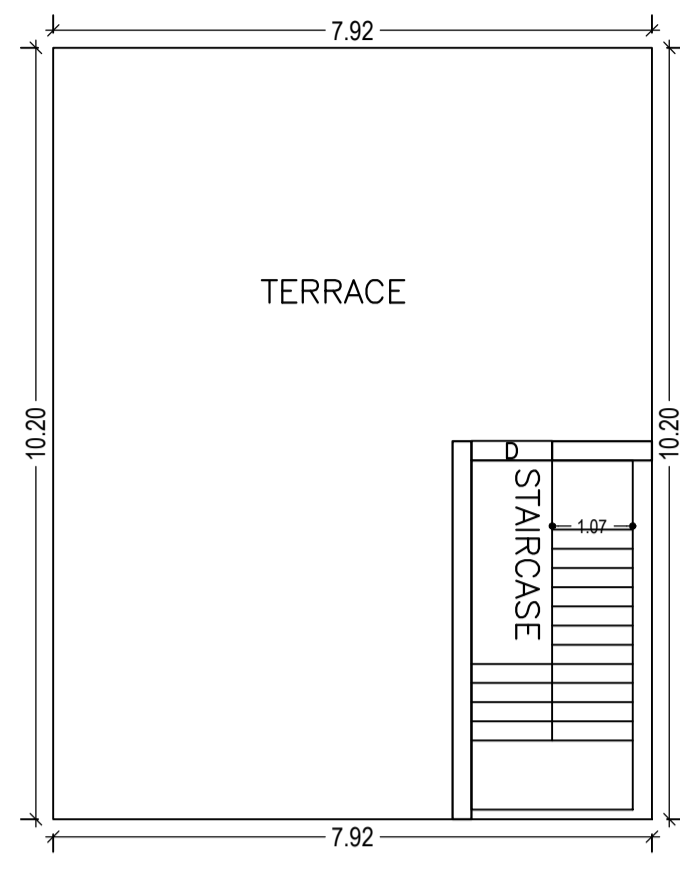
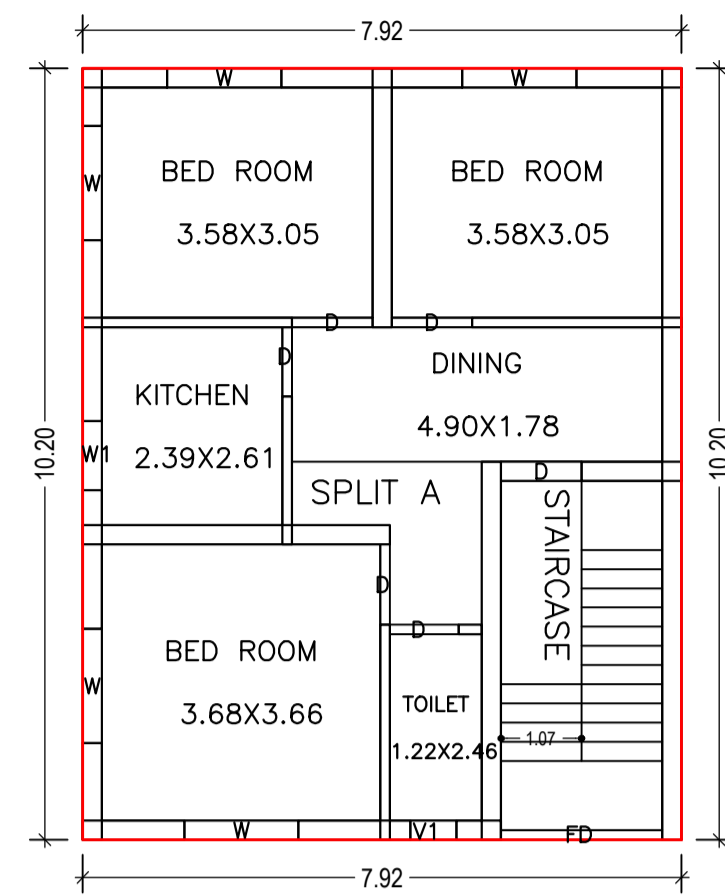

GROUND FLOOR PLAN (Proposed) (SCALE 1:100)

TERRACE FLOOR PLAN (SCALE 1:100)

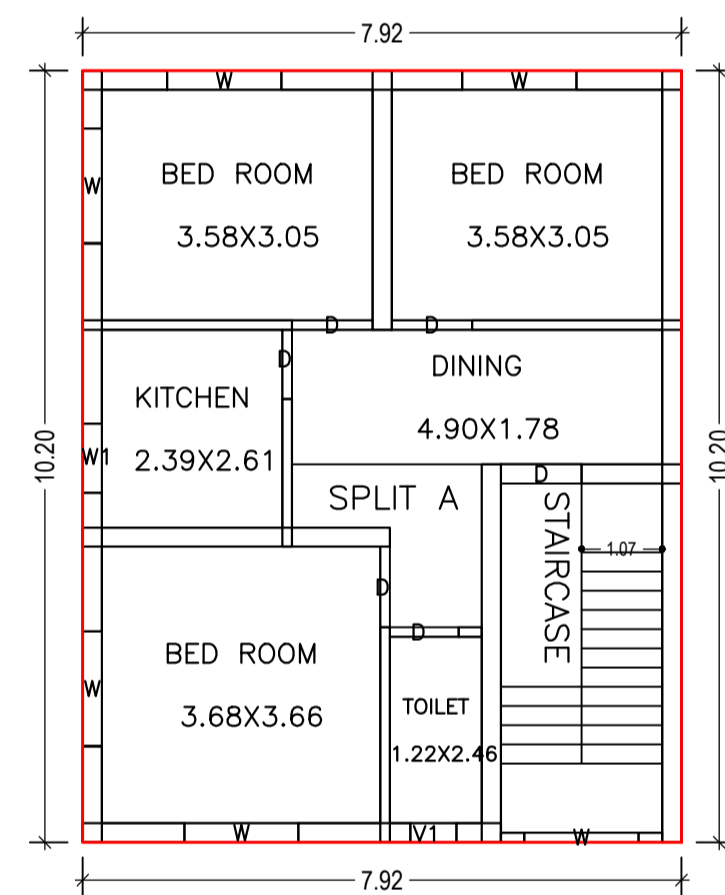

FIRST FLOOR PLAN (Proposed) (SCALE 1:100)

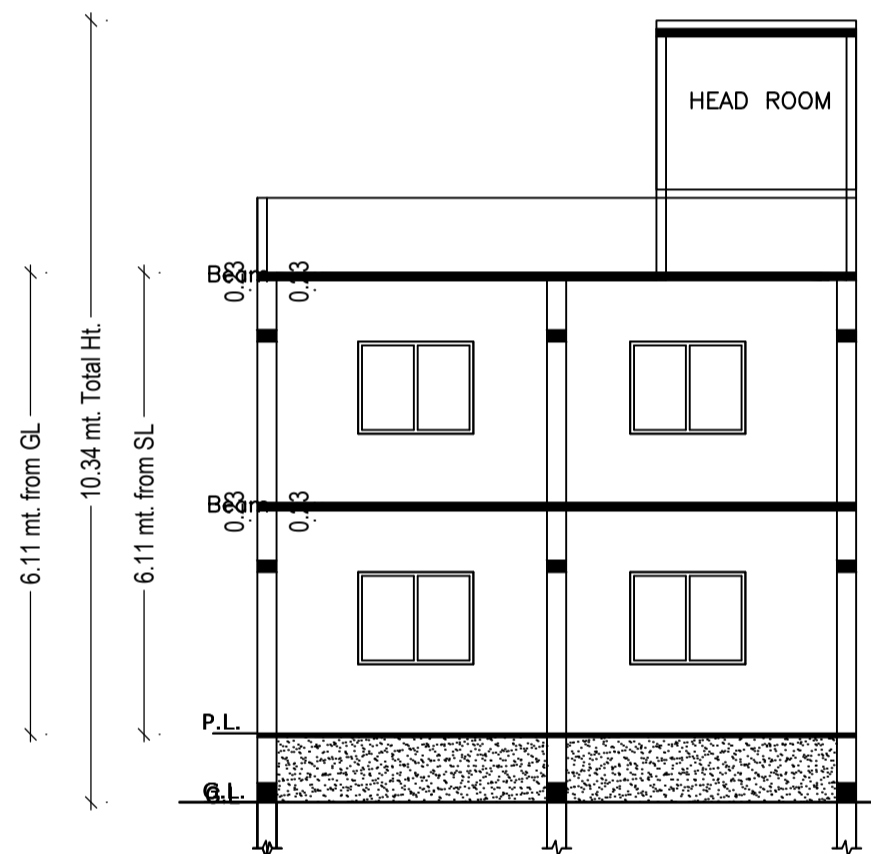

SECTION-BB

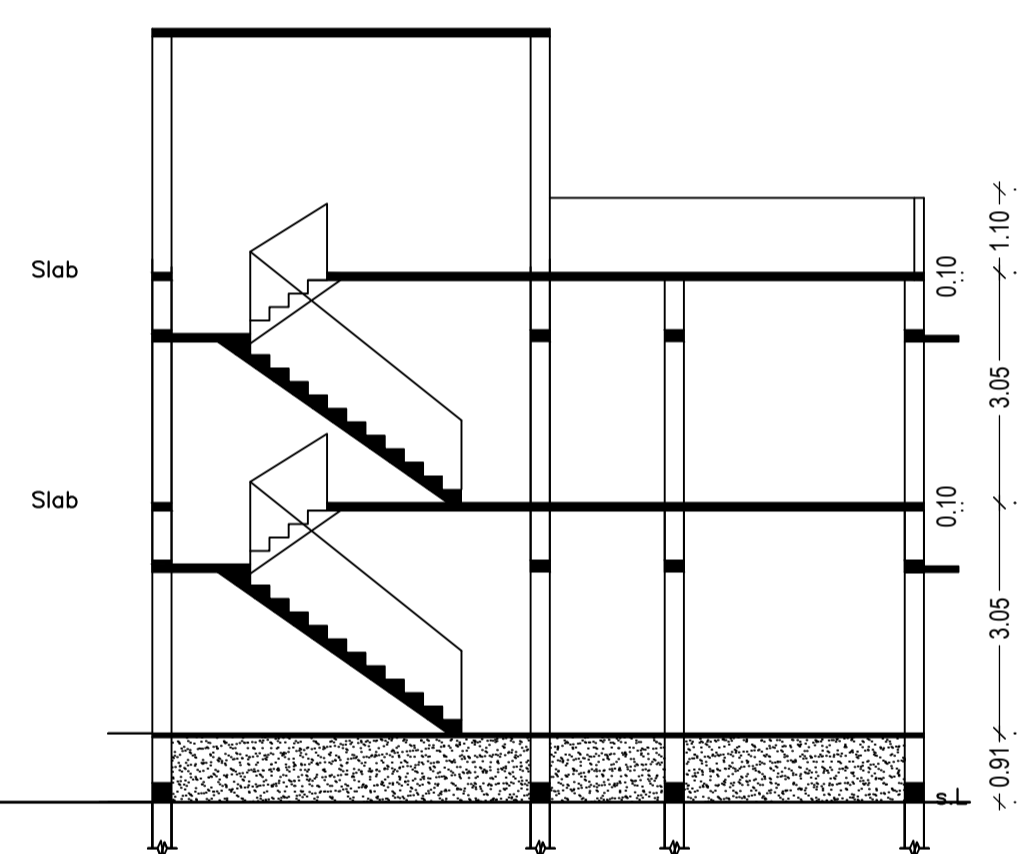

SECTION-AA

BUILDING HEIGHT

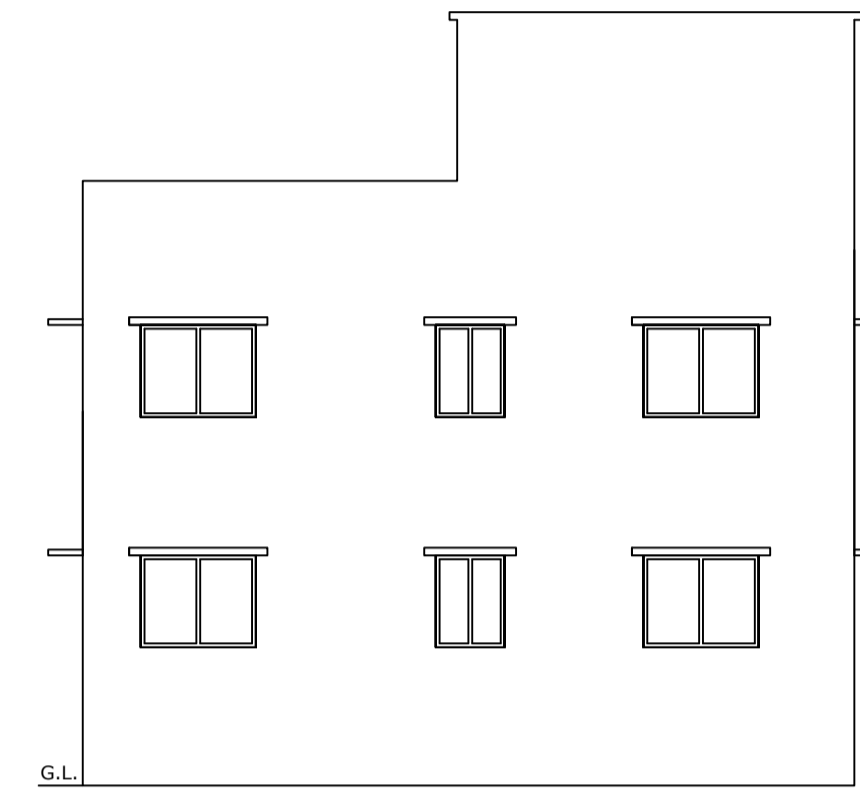

SOUTH SIDE ELEVATION

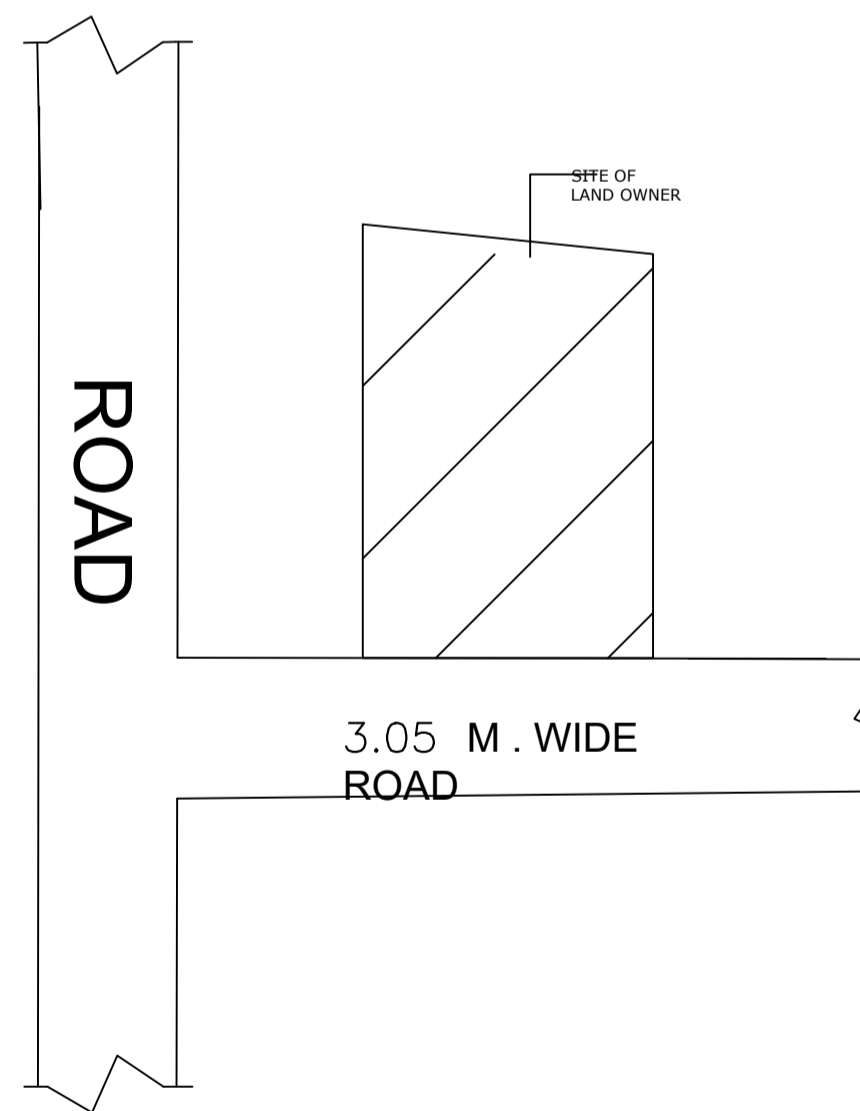

3.05 M . WIDE ROAD

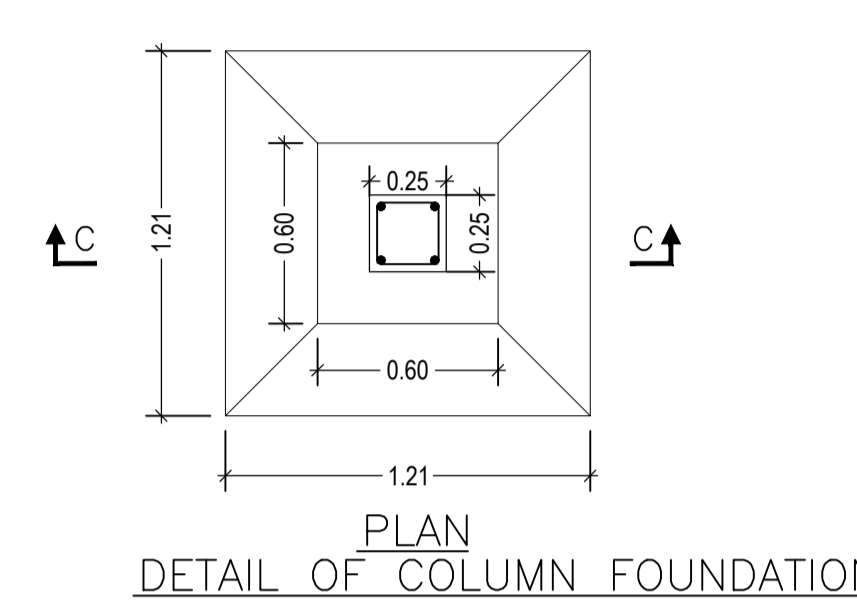

PLAN DETAIL OF COLUMN FOUNDATION

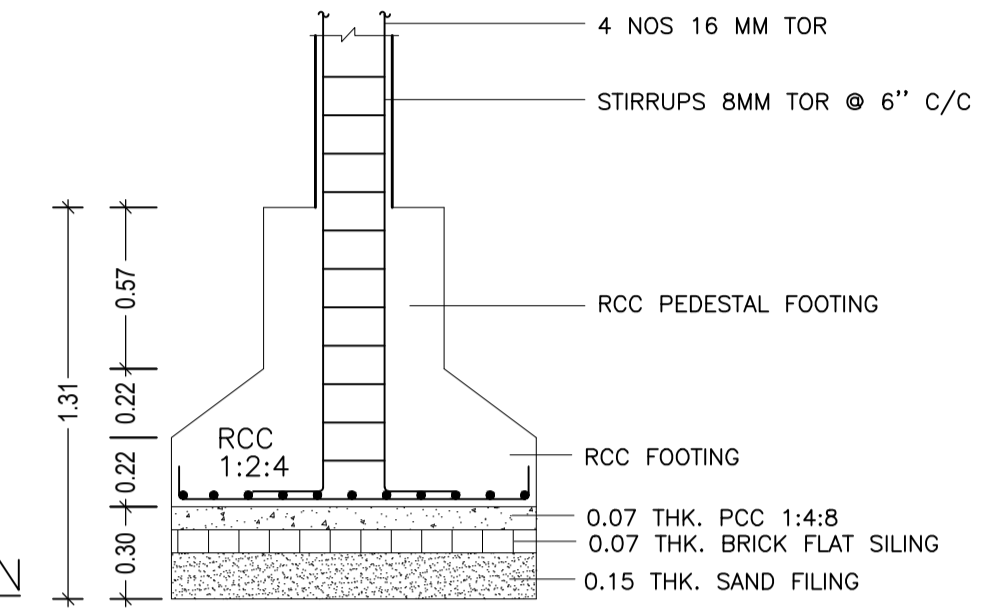

SECTION - C-C

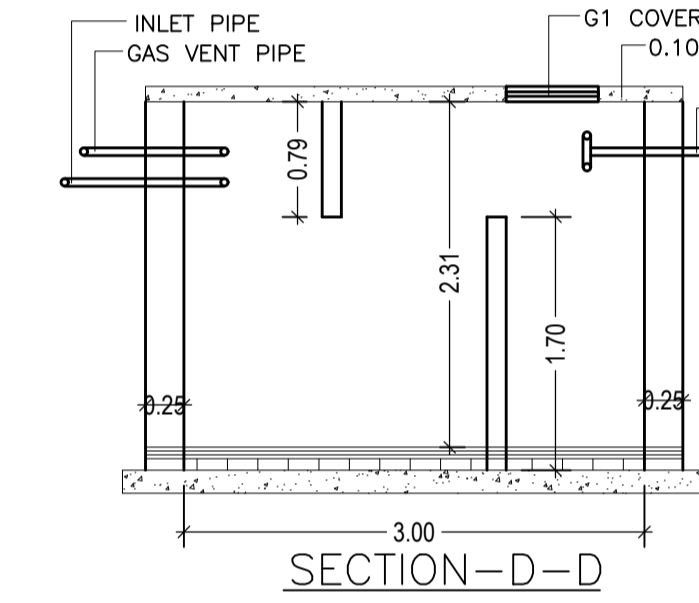

SECTION-D-D

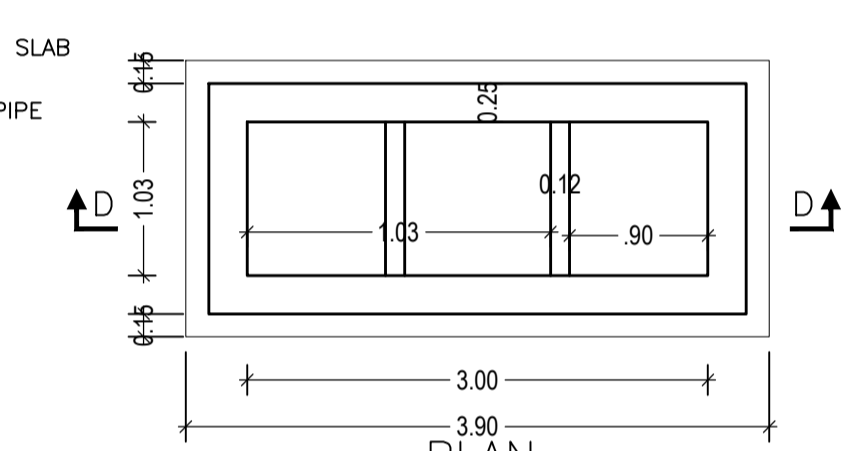

DETAIL OF SEPTIC TANK.

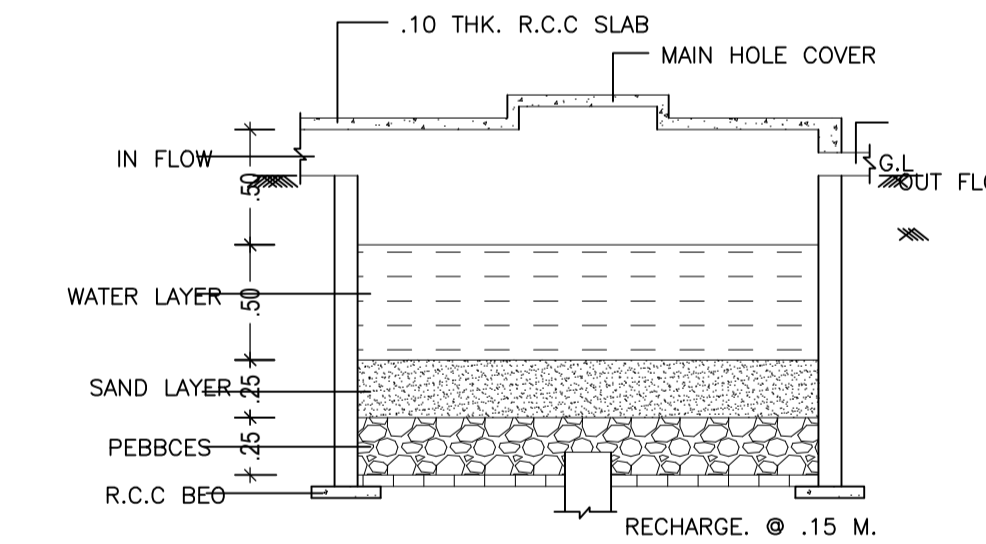

DETAIL OF RAIN WATER HARVESTING AND RECHARGE PIT.(N.T.S)

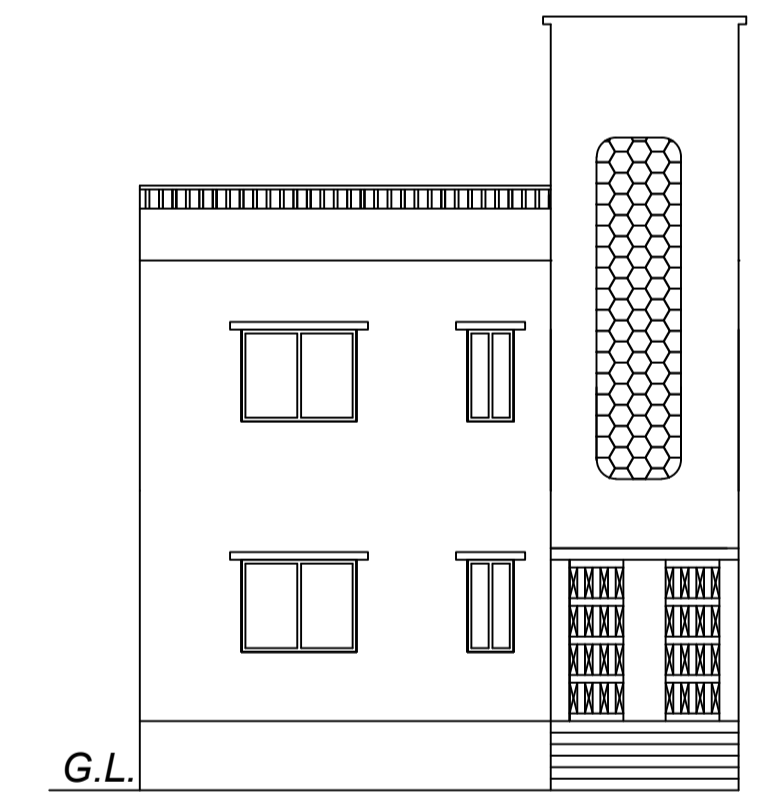

FRONT ELEVATION

Building :A (A1)

Floor Name	Total Built Up Area (Sq.mt.)	Proposed FAR Area (Sq.mt.) Resi.	Total FAR Area (Sq.mt.)	Total Consumed Additional FAR Area (Sq.mt.)	Tnmt (No.)
Ground Floor	80.82	80.82	80.82	80.82	01
First Floor	80.82	80.82	80.82	80.82	00
Terrace Floor	0.00	0.00	0.00	0.00	00
Total :	161.64	161.64	161.64	161.64	01
Total Number of Same Buildings	1				
Total :	161.64	161.64	161.64	161.64	01

SCHEDULE OF DOOR:

BUILDING NAME	NAME	LENGTH	HEIGHT	NOS
A (A1)	D	0.91	2.10	04
A (A1)	D	1.07	2.10	08

SCHEDULE OF WINDOW/VENTILATION:

BUILDING NAME	NAME	LENGTH	HEIGHT	NOS
A (A1)	V1	0.61	1.20	02
A (A1)	W1	0.91	1.20	02
A (A1)	W	1.51	1.20	11

UnitBUA Table for Building :A (A1)

FLOOR	Name	UnitBUA Type	UnitBUA Area	Carpet Area	No. of Rooms	No. of Tenement
GROUND FLOOR PLAN	SPLIT A	FLAT	161.64	139.27	6	1
FIRST FLOOR PLAN	SPLIT A	FLAT	0.00	0.00	6	0
Total:	-	-	161.64	139.27	12	1

LTP NAME AND SIGNATURE	STRUCTURAL ENG'S NAME AND SIGNATURE	BUILDER NAME AND SIGNATURE	DIGITAL SIGNATURE
law chaturvedi LNPC/ENG/0004/2018			

Proposal Basic Information

Proposal File No.	LNPC/BP/0018/W11/2020
Owner Name	PRIYA SINGH
Khata No	46
Plot No	254
Village Name	Latehar
Use	Residential
SubUse	Bungalow/ Dwelling / Non Apartment

PLOTNO. – 253

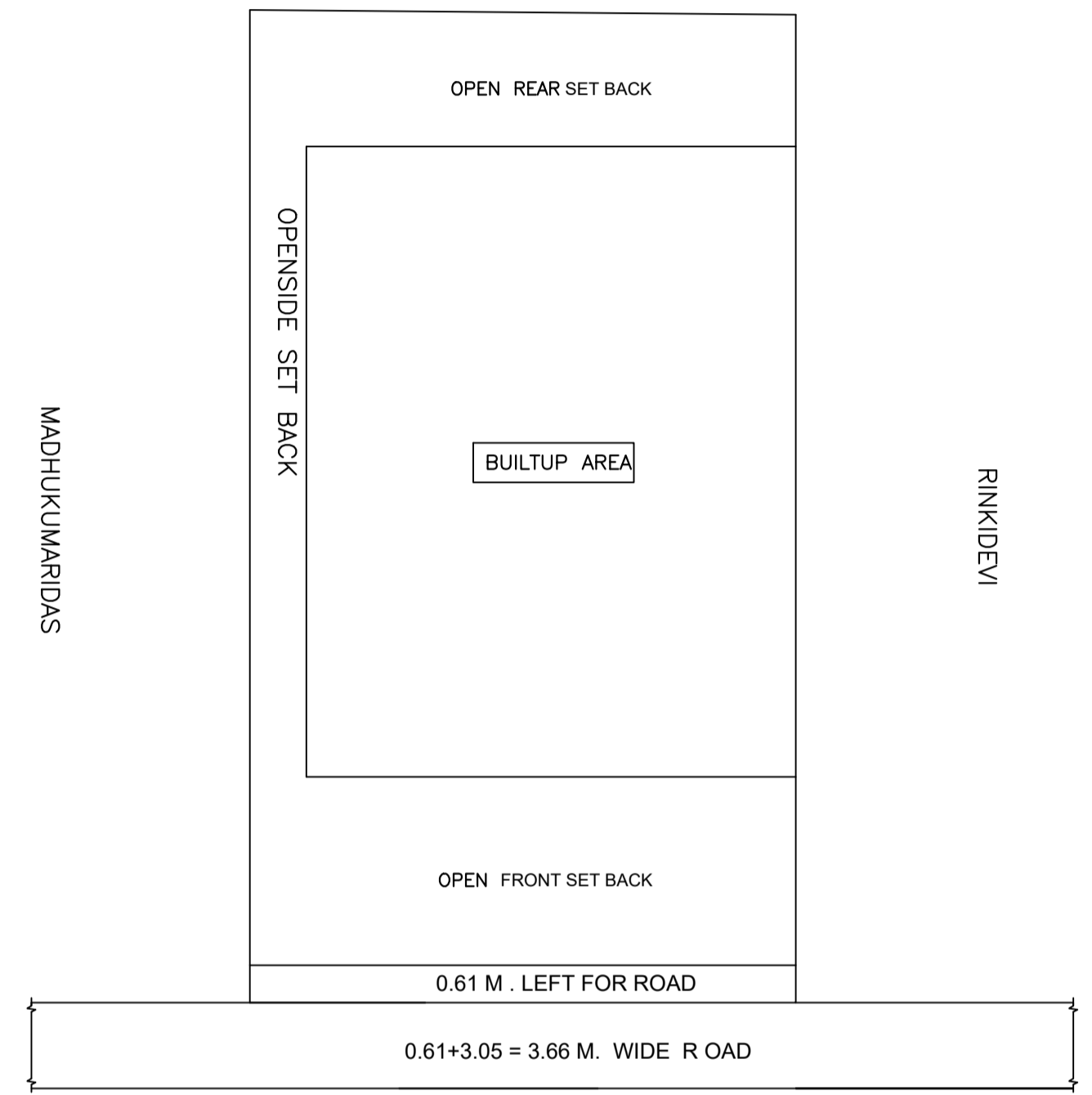

SITE PLAN

LTP NAME AND SIGNATURE	STRUCTURAL ENG'S NAME AND SIGNATURE	BUILDER NAME AND SIGNATURE	DIGITAL SIGNATURE
law chaturvedi LNPC/ENG/0004/2018			