

**SITE PLAN**

SITE PLAN

**FAR & Tenement Details (Table 4c-1)**

Building	No. of Same Bldg	Total Built Up Area (Sq.mt.)	Proposed FAR Area (Sq.mt.) Resi.	Total FAR Area (Sq.mt.)	Total Consumed Additional FAR Area (Sq.mt.)	Tnmt (No.)
A (SMT MANJU DEVI)	1	275.06	275.06	275.06	275.06	01
<b>Grand Total :</b>	<b>1</b>	<b>275.06</b>	<b>275.06</b>	<b>275.06</b>	<b>275.06</b>	<b>01</b>

**Proposal Basic Information**

Proposal File No.	LNPC/BP/0009/W02/2022
Owner Name	MANJU DEVI
Khata No	14
Plot No	638/637/626
Village Name	Latehar
Use	Residential
SubUse	Bungalow/ Dwelling / Non Apartment

AREA STATEMENT LATEHAR NAGAR PANCHAYAT		VERSION NO. : 1.0.62
PROJECT DETAIL:		VERSION DATE: 16/10/2020
Region: JHARKHAND URBAN LOCAL BODIES	Plot Use: Residential	
District: LATEHAR	Plot SubUse: Bungalow/ Dwelling / Non Apartment	
Authority: LATEHAR NAGAR PANCHAYAT	PlotNearbyReligiousStructure: NA	
Inward_No: LNPCI/BP/0009/W02/2022	PlotSubPlot No: 638/637/626	
Application Type: General Proposal	North: Plot No. - BAGWAN SAW	
Project Type: Building Permission	South: Plot No. - BADRI PRASAD	
Nature of Development: New	East: Road Width - ROAD	
Location of Development Area: Old Area	West: Plot No. - PREMCHAND DAS	
<b>AREA DETAILS:</b>		
AREA OF PLOT (Minimum)	(A)	SQ. MT. 322.22
Deduction for NetPlot Area		
Surrender Free of Cost		8.98
Total		8.98
NET AREA OF PLOT(Gross Plot Area - Deduction from Gross Plot area)	(A-Deductions)	313.24
Deduction for Balance Plot Area(from Gross Plot Area)		
Surrender Free of Cost		8.98
Common Plot		32.79
Total		41.77
BALANCE AREA OF PLOT(Net Plot Area - Recreational/Amenity space)	(A-Deductions)	280.45
PLOT AREA FOR COVERAGE(Net Plot Area)	(A-Deductions)	313.24
Plot Area for FAR (Net Plot Area + Road Widening Area)	(A-Deductions)	322.22
<b>COVERAGE CHECK</b>		
Permissible Coverage area ( 60.00 % )		187.94
Proposed Coverage Area ( 43.91 % )		137.53
Total Prop. Coverage Area ( 43.91 % )		137.53
Balance coverage area ( 16.09 % )		50.41
<b>FAR CHECK</b>		
Perm. FAR Area ( 1.50 )		483.33
Total Perm. FAR area		483.33
Residential FAR		275.06
Proposed FAR Area		275.06
Total Proposed FAR Area		275.06
Consumed FAR (Factor)		0.85
Balance FAR Area		208.27
<b>BUILT UP AREA CHECK</b>		
Total Proposed BuiltUp Area		275.06
ARCHITECT (Regd)	law chaturvedi	
ENGINEER (Regd)		
SUPERVISOR (Regd)		
OWNER (Regd)	MANJU DEVI	
DEVELOPMENT AUTHORITY		LOCAL BODY

<b>COLOR INDEX</b>	
PLOT BOUNDARY	Black
ABUTTING ROAD	Green
PROPOSED CONSTRUCTION	Red
COMMON PLOT	Yellow
ROAD WIDENING AREA	Blue
EXISTING (To be retained)	Light Blue
EXISTING (To be demolished)	Light Yellow

**Buildingwise Floor FAR Details**

Floor Name	Building Name		Total	
	Proposed Built Up Area (Sq.mt.)	Proposed FAR Area (Sq.mt.)	Total Proposed Built Up Area (Sq.mt.)	Total FAR Area (Sq.mt.)
Ground Floor	137.53	137.53	137.53	137.53
First Floor	137.53	137.53	137.53	137.53
Terrace Floor	0.00	0.00	0.00	0.00
<b>Total :</b>	<b>275.06</b>	<b>275.06</b>	<b>275.06</b>	<b>275.06</b>

**Building USE/SUBUSE Details**

Building Name	Building Use	Building SubUse	Building Structure
A (SMT MANJU DEVI)	Residential	Bungalow/ Dwelling / Non Apartment	Non-Highrise

LTP NAME AND SIGNATURE	STRUCTURAL ENG'S NAME AND SIGNATURE	BUILDER NAME AND SIGNATURE	DIGITAL SIGNATURE
law chaturvedi LNPCI/ENG/0004/2018			

Proposal Basic Information	
Proposal File No.	LNPC/BP/0009/W02/2022
Owner Name	MANJU DEVI
Khata No	14
Plot No	638/637/626
Village Name	Latehar
Use	Residential
SubUse	Bungalow/ Dwelling / Non Apartment

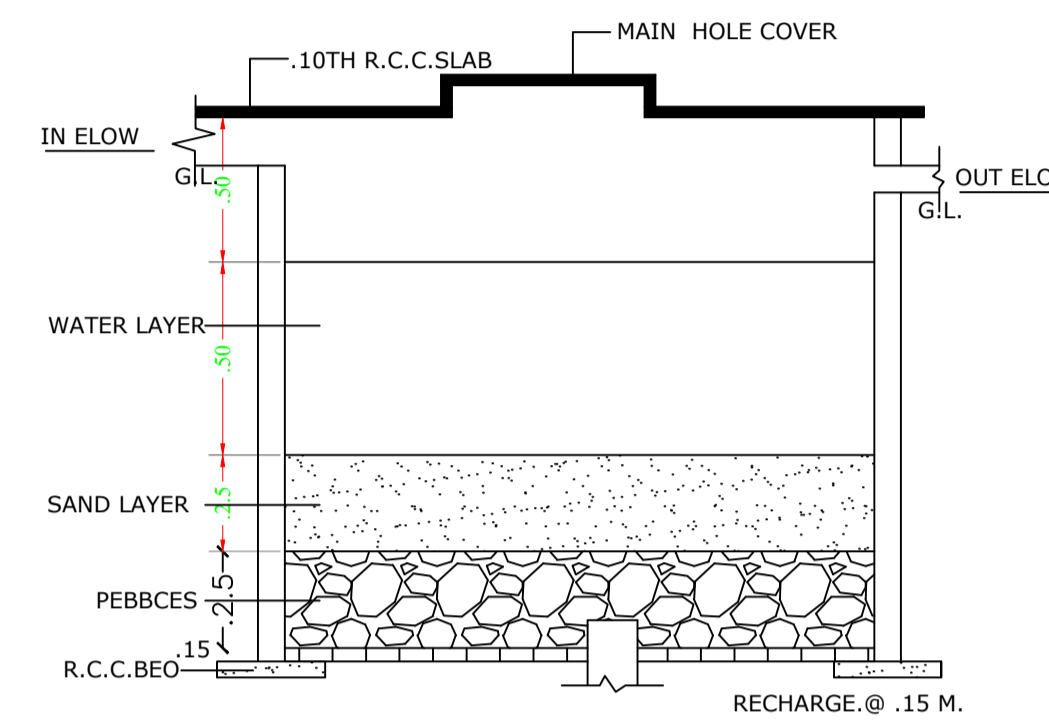
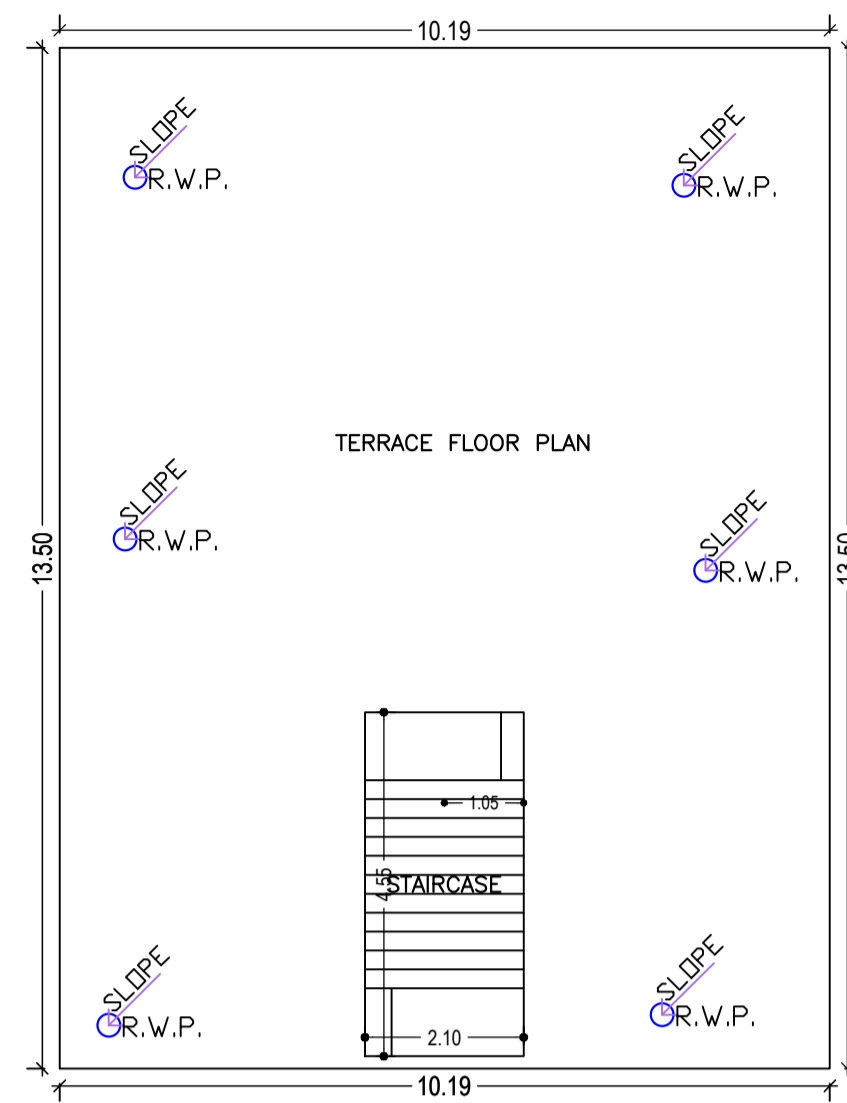
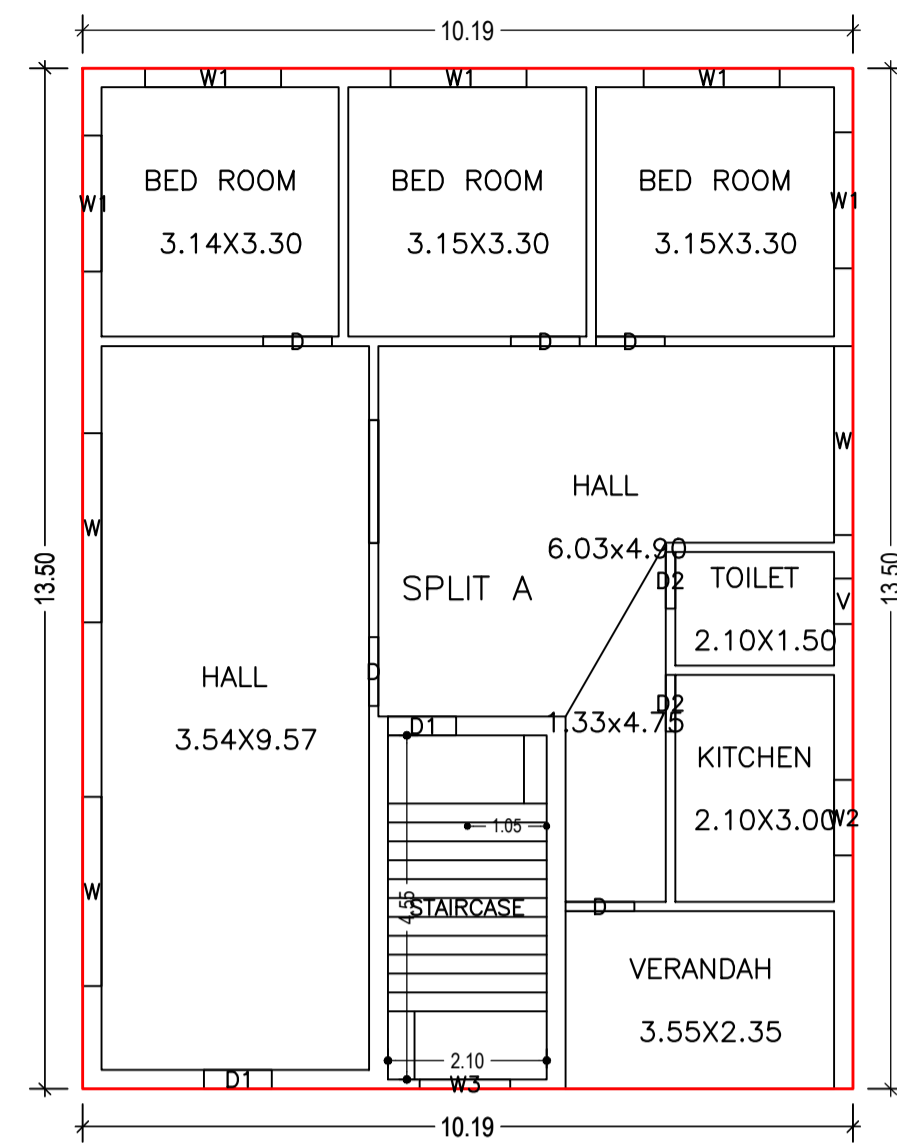

GROUND FLOOR PLAN (Proposed) (SCALE 1:100)

TERRACE FLOOR PLAN (SCALE 1:100)

DETAIL OF RAIN WATER HARVESTING AND RECHARGE PIT (N.T.S.)

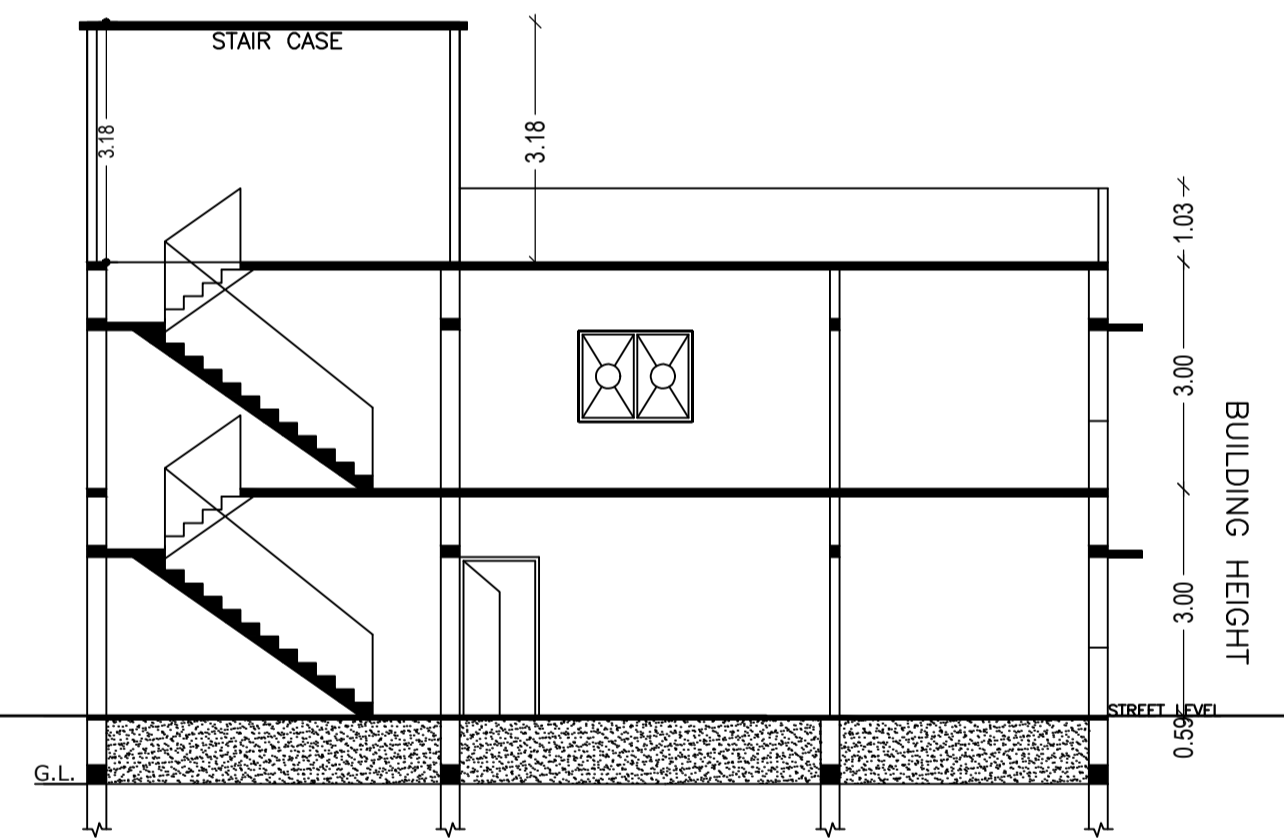
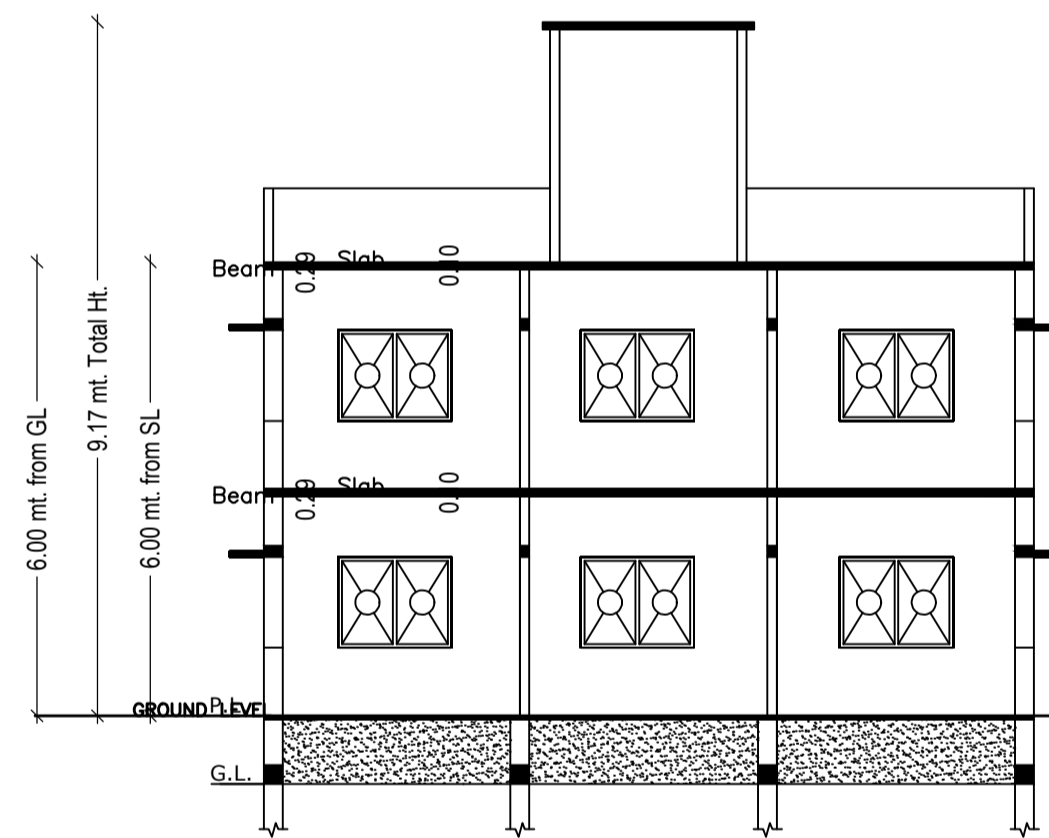
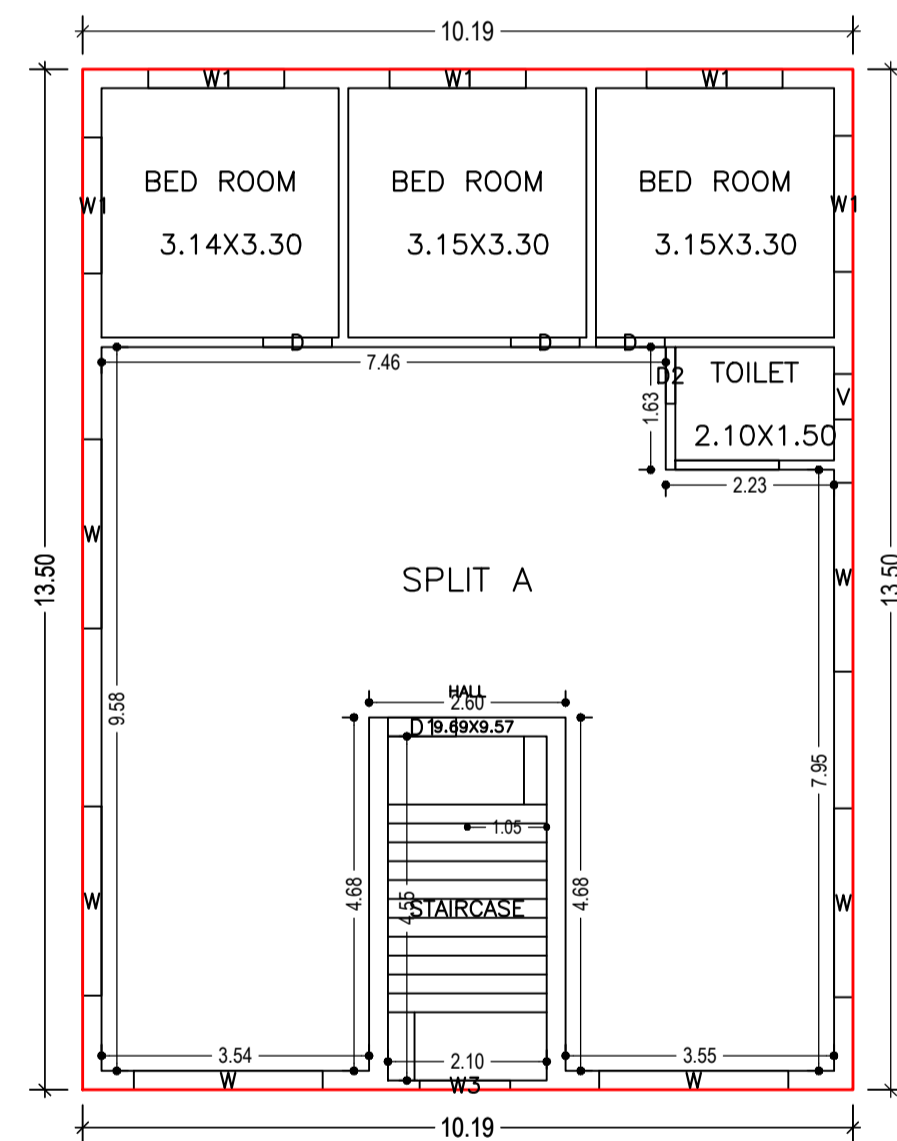

SECTION - YY

SECTION - XX

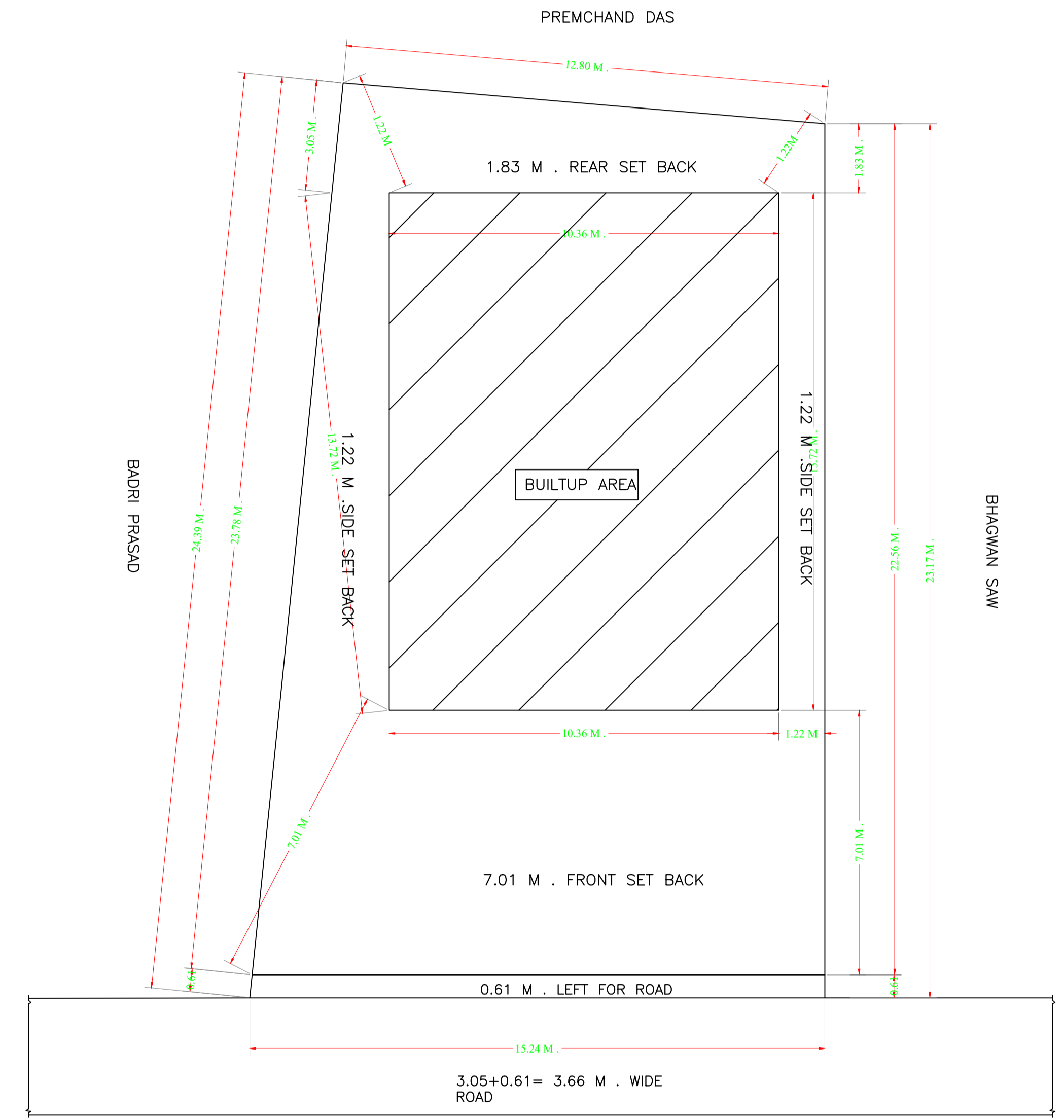

SITE PLAN

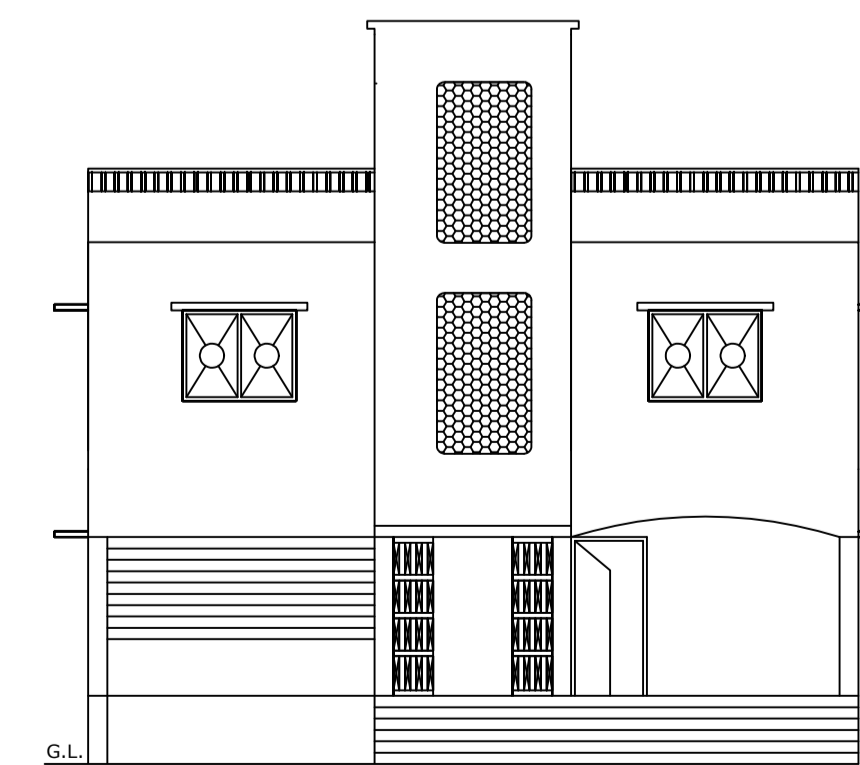

FRONT ELEVATION

Building :A (SMT MANJU DEVI)

Floor Name	Total Built Up Area (Sq.mt.)	Proposed FAR Area (Sq.mt.)	Total FAR Area (Sq.mt.)	Total Consumed Additional FAR Area (Sq.mt.)	Tnmt (No.)
Ground Floor	137.53	137.53	137.53	137.53	01
First Floor	137.53	137.53	137.53	137.53	00
Terrace Floor	0.00	0.00	0.00	0.00	00
Total:	275.06	275.06	275.06	275.06	01
Total Number of Same Buildings	1				
Total:	275.06	275.06	275.06	275.06	01

SCHEDULE OF DOOR:

BUILDING NAME	NAME	LENGTH	HEIGHT	NOS
A (SMT MANJU DEVI)	D2	0.75	2.13	03
A (SMT MANJU DEVI)	D1	0.90	2.13	03
A (SMT MANJU DEVI)	D	0.91	2.13	08

SCHEDULE OF WINDOW/VENTILATION:

BUILDING NAME	NAME	LENGTH	HEIGHT	NOS
A (SMT MANJU DEVI)	V	0.60	2.00	02
A (SMT MANJU DEVI)	W2	1.00	2.70	01
A (SMT MANJU DEVI)	W3	1.20	2.70	02
A (SMT MANJU DEVI)	W1	1.80	2.70	10
A (SMT MANJU DEVI)	W	2.50	2.70	09

UnitBUA Table for Building :A (SMT MANJU DEVI)

FLOOR	Name	UnitBUA Type	UnitBUA Area	Carpet Area	No. of Rooms	No. of Tenement
GROUND FLOOR PLAN	SPLIT A	FLAT	228.45	228.08	8	1
FIRST FLOOR PLAN	SPLIT A	FLAT	0.00	0.00	5	0
Total:	-	-	228.45	228.08	13	1

LTP NAME AND SIGNATURE	STRUCTURAL ENG'S NAME AND SIGNATURE	BUILDER NAME AND SIGNATURE	DIGITAL SIGNATURE
law chaturvedi LNPC/ENG/0004/2018			

Proposal Basic Information	
Proposal File No.	LNPC/BP/0009/W02/2022
Owner Name	MANJU DEVI
Khata No	14
Plot No	638/637/626
Village Name	Latehar
Use	Residential
SubUse	Bungalow/ Dwelling / Non Apartment

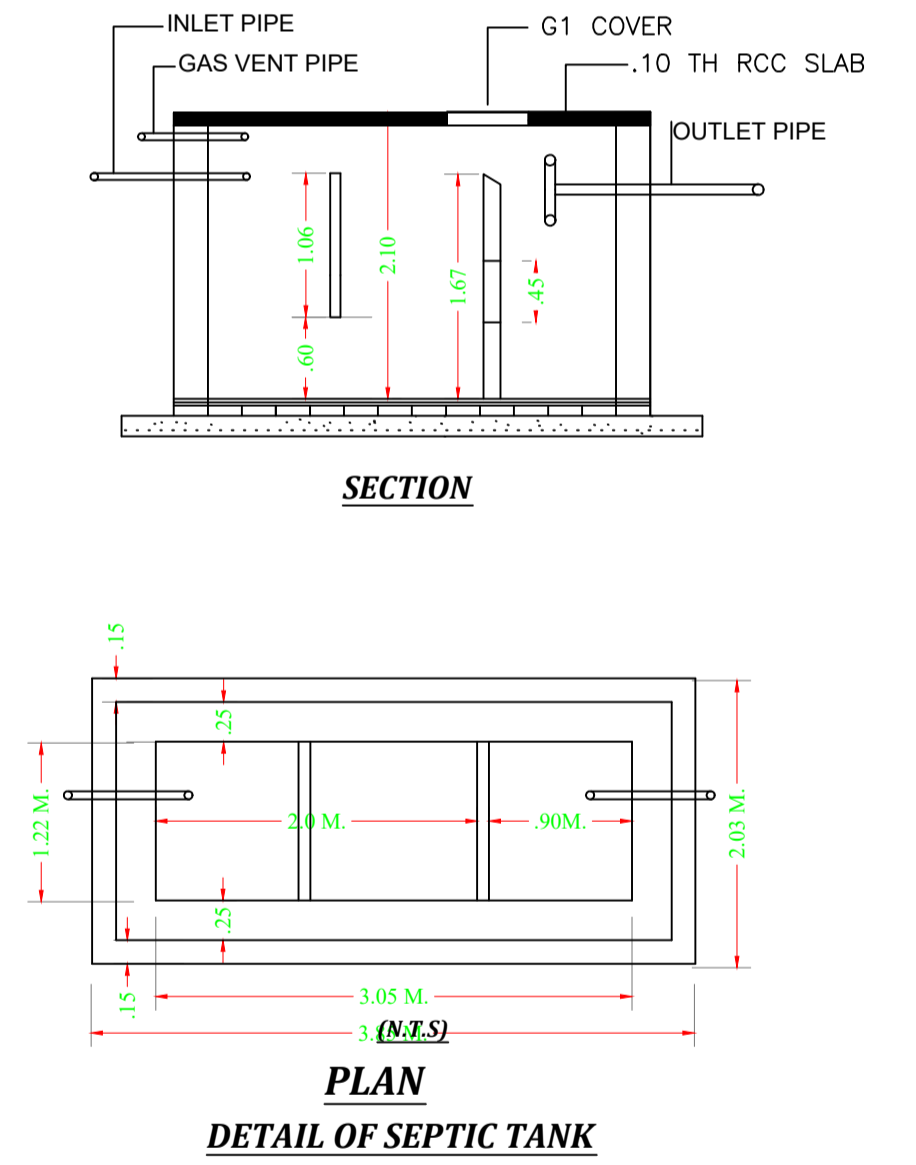
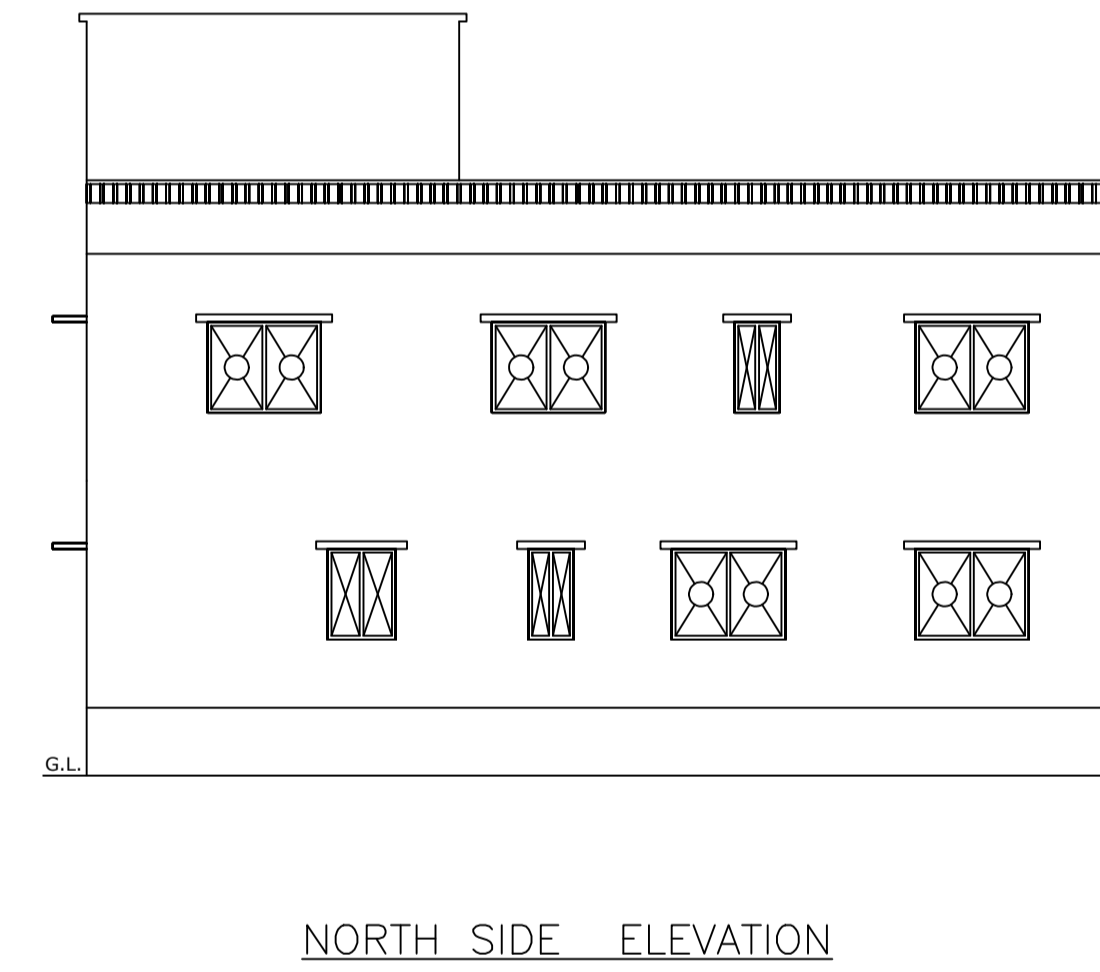
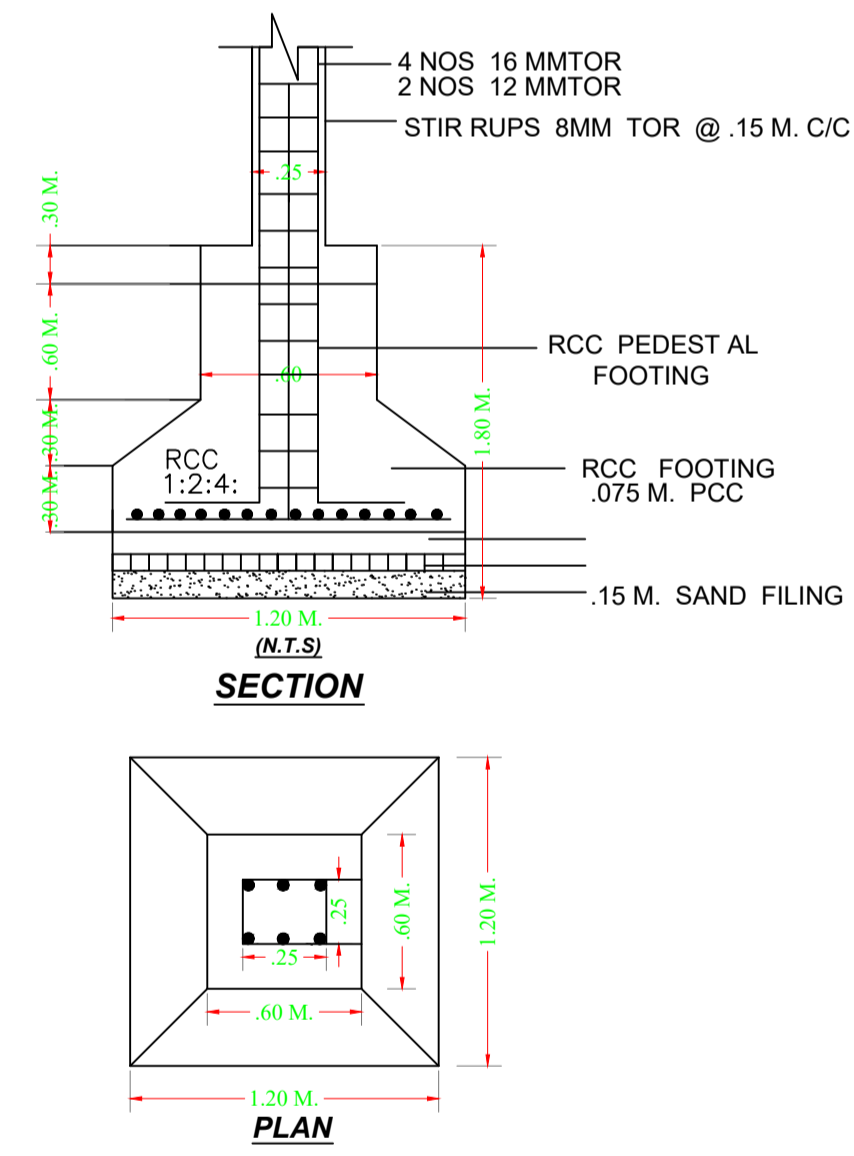
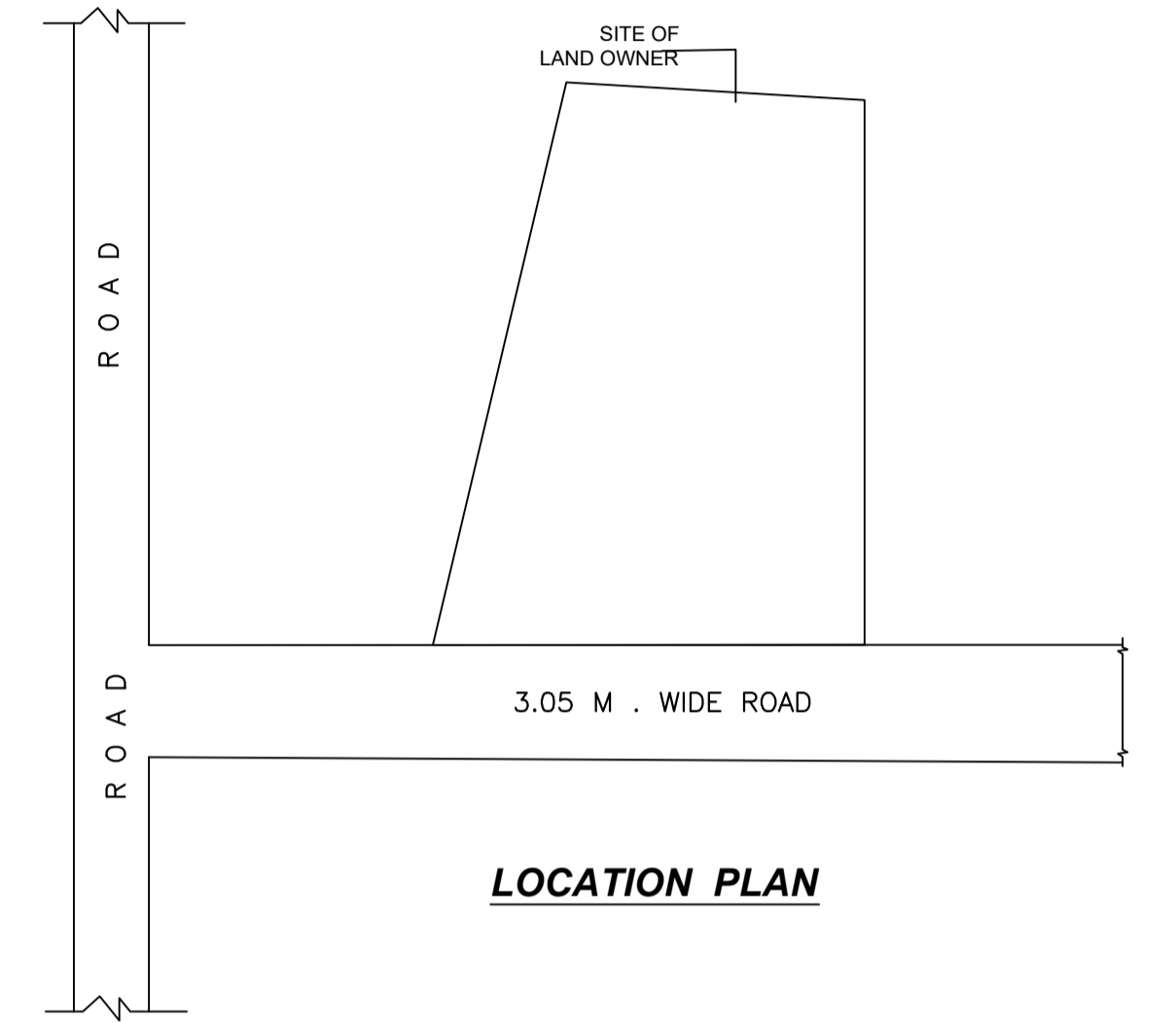

LTP NAME AND SIGNATURE	STRUCTURAL ENG'S NAME AND SIGNATURE	BUILDER NAME AND SIGNATURE	DIGITAL SIGNATURE
law chaturvedi LNPC/ENG/0004/2018			