

FRONT ELEVATION

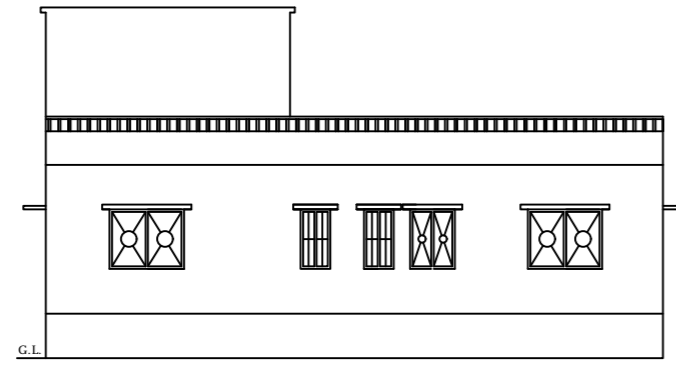

NORTH SIDE ELEVATION

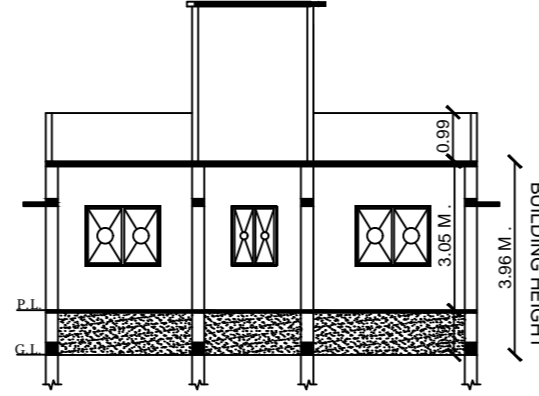

SECTION-YY

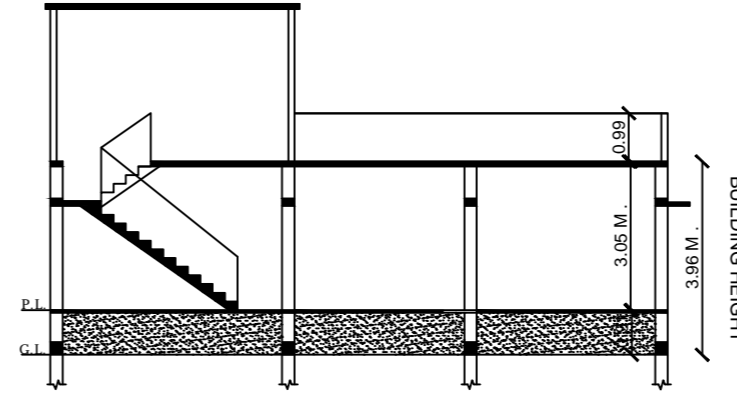

SECTION-XX

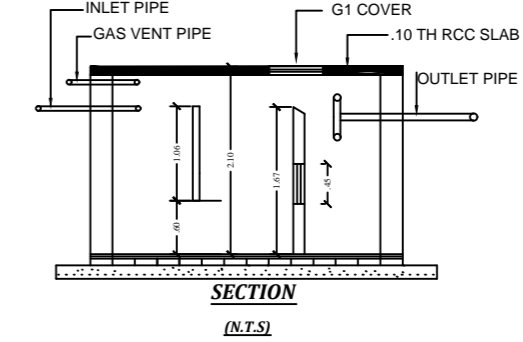

SECTION
(N.T.S)

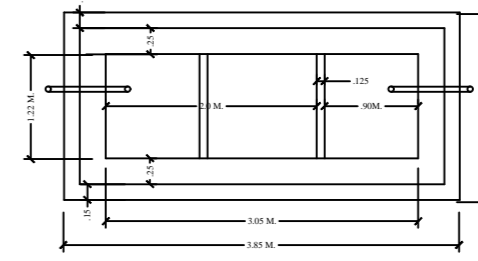

PLAN
DETAIL OF SEPTIC TANK

SCHEDULE OF DS & WS

TYPE	SIZE	REMARKS
D	1.06 M.X2.10 M.	F PANELED
D1	0.06 M.X2.10 M.	F PANELED
D2	0.75 M.X2.10 M.	F PANELED
W	1.50 M.X1.20 M.	F GLAZZED
W1	1.20 M.X1.20 M.	F GLAZZED
W2	0.91 M.X1.20 M.	F GLAZZED
C.GATE	2.10 M.X2.10 M.	IRON

SPECIFICATION

- DETAIL OF R.C.C. FOOTING COLUMN FON (M.25)
- 1ST CLASS BRICK WORK IN CEMENT PLASTER (1:6)
- 1.25X.15TH. R.C.C. LINTEL BAND OVER DOOR'S & WINDOW'S
- 10TH. LIME CON. TERR.OVER .10TH. R.C.C. ROOF SLAB(M.25)
- SAL WOOD FRAME & SUAM WOOD SHUTTER.
- 0.012TH. IN CEMENT PLASTER IN BOTH SIDE WACC (1:6)
- MARBLE OR MOSAIC FLOORING OVER .110TH. DRY RAMMED KHOA OVER B.F. SOILING , OVER LOCAL SAND FILLING .
- 2 CUAT OF WHITE & COLOUR WASH AS PER CHOICE .
- 17CM.WIDE & 30 CM. PUCCA DRAIN AROUND THE BUILDING .

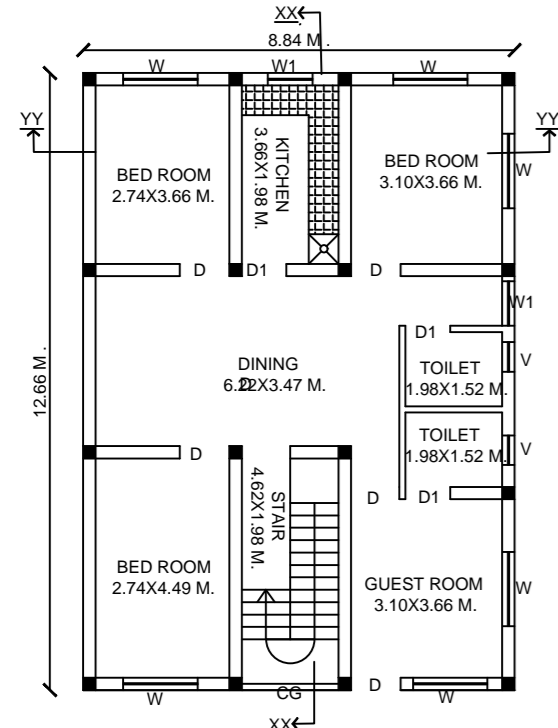

PROPOSED GROUND FLOOR PLAN

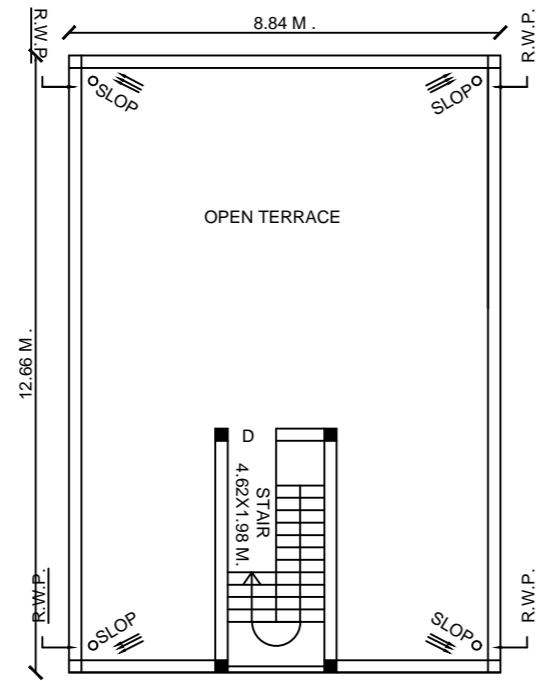

TERRACE FLOOR PLAN

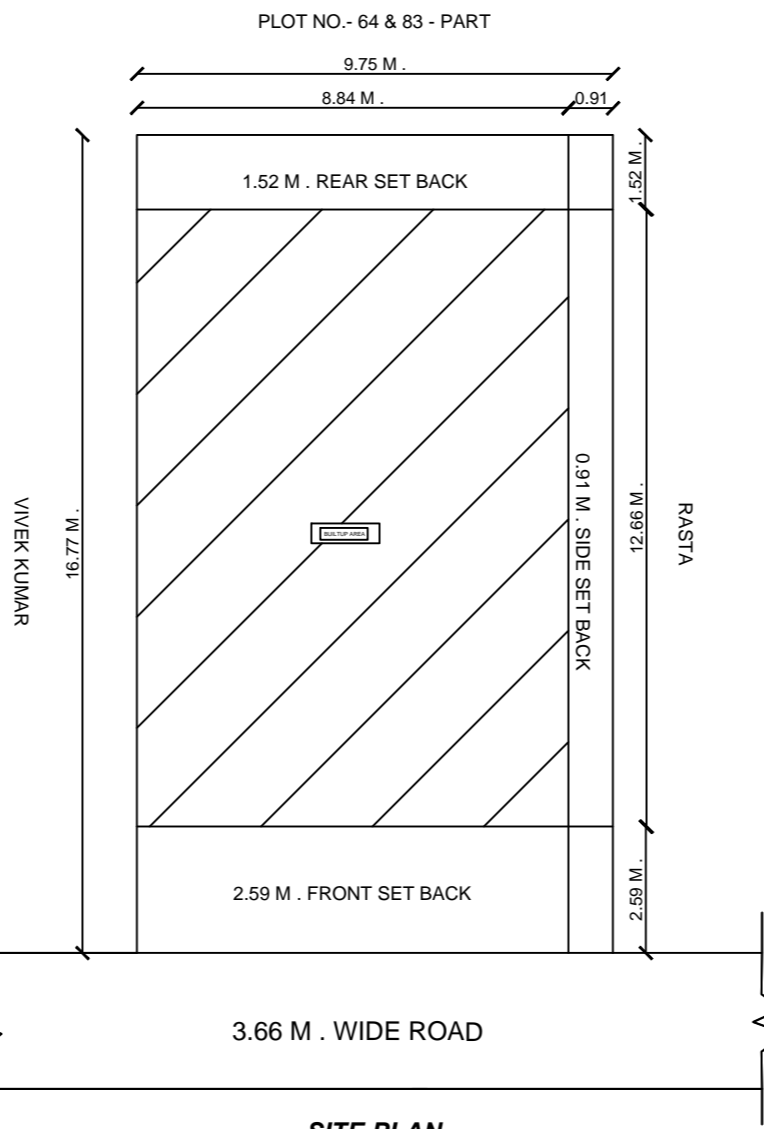

SITE PLAN

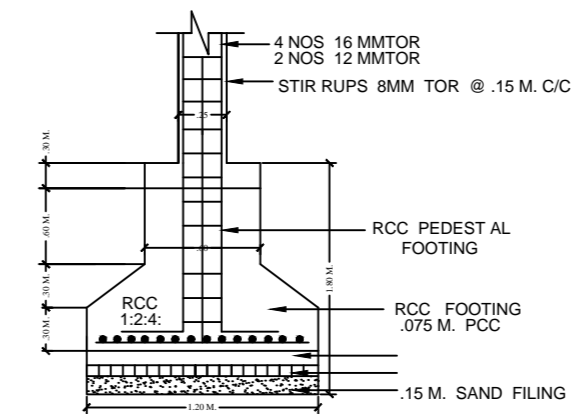

SECTION
(N.T.S)

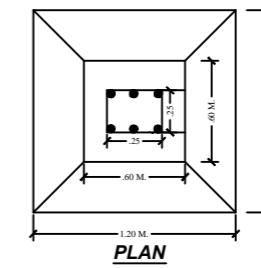

PLAN

TOTAL PLOT AREA	=	163.50 SQM.
NET PLOT AREA	=	163.50 SQM.
TOTAL OPEN LAND AREA	=	51.59 SQM.
GROUND FLOOR B/A	=	111.91 SQM.
TOTAL B/A	=	111.91 SQM.
F.A.R.	=	0.68
% OF COVRED AREA	=	68 %
BUILDING HEIGHT	=	3.96 M.

PROPOSED RESIDENTIAL BUILDING OF
 NAME- SMT. RINKI KUMARI
 S/O. - SRI CHANDAN KUMAR
 MAUZA - RAJHAR
 P.S. - LATEHAR
 P.S. NO. - 186
 WARD NO. - 02
 KHATA NO. - 31
 H. NO. - 7/6
 PLOT NO. - 83
 TOUZI NO. - 51
 DIST. - LATEHAR (JHARKHAND)

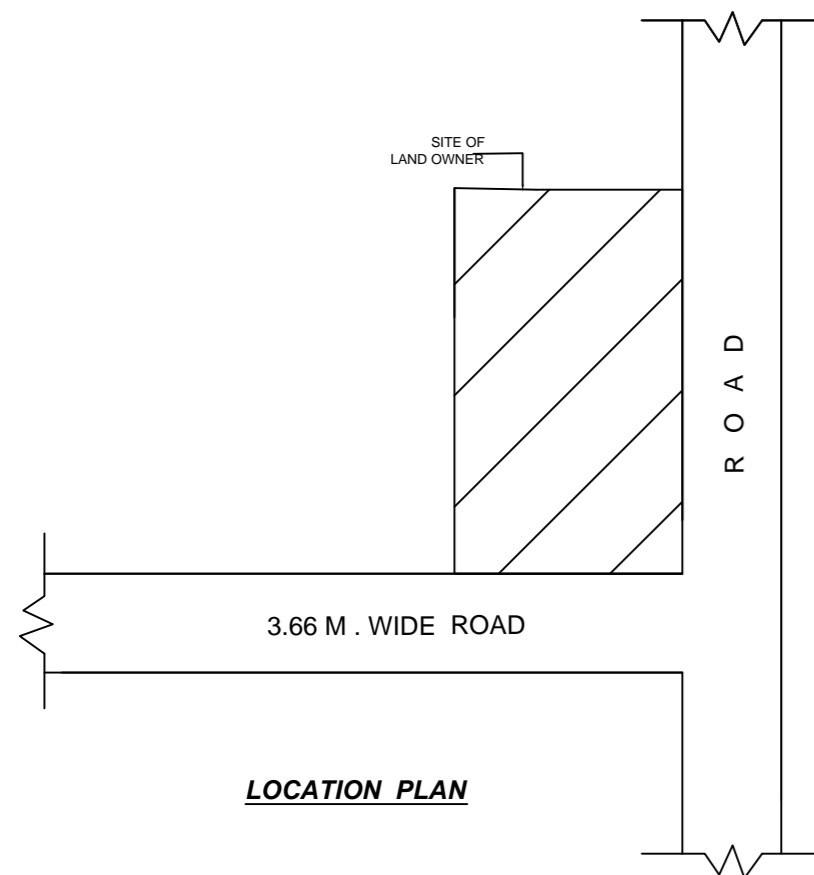

LOCATION PLAN

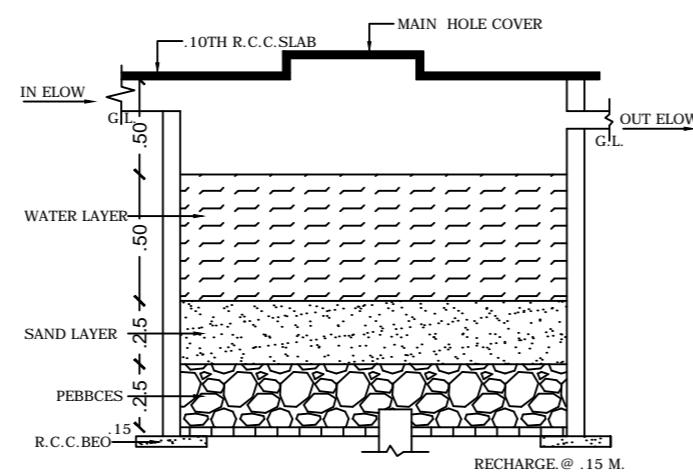

DETAIL OF RAIN WATER HARVESTING AND RECHARGE PIT.(N.T.S.)

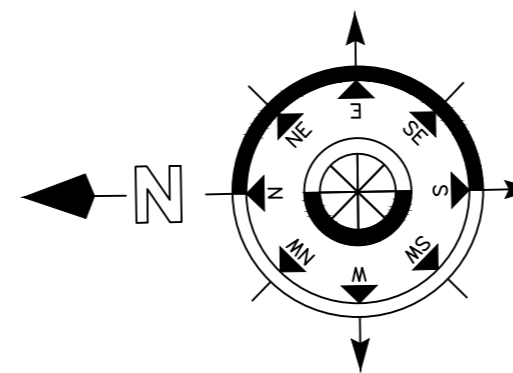

MAP APPROVED BY

SIGNATURE OF APPLICANT

SIGNATURE OF ENGINEER