

SITE PLAN

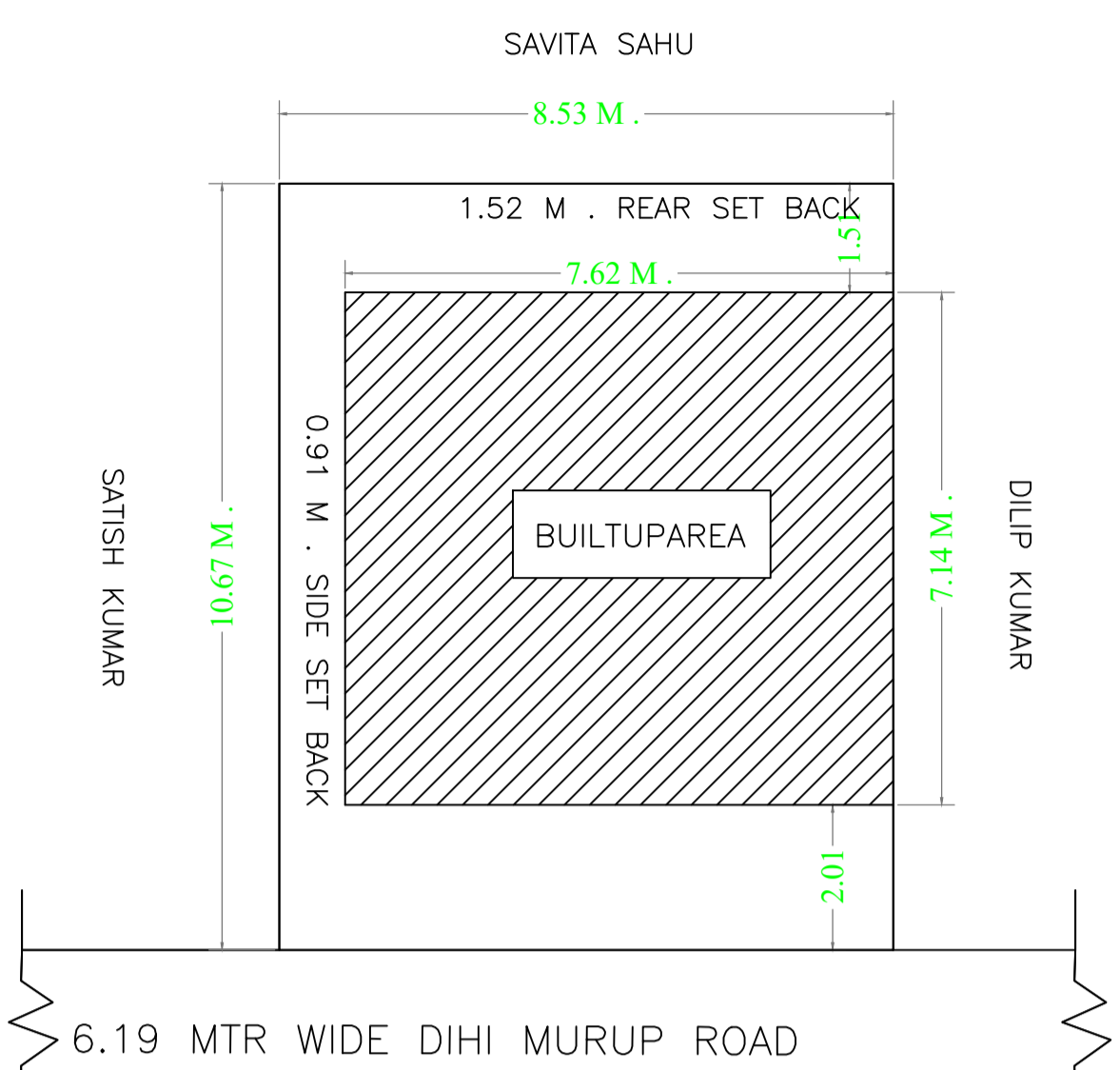

SITE PLAN

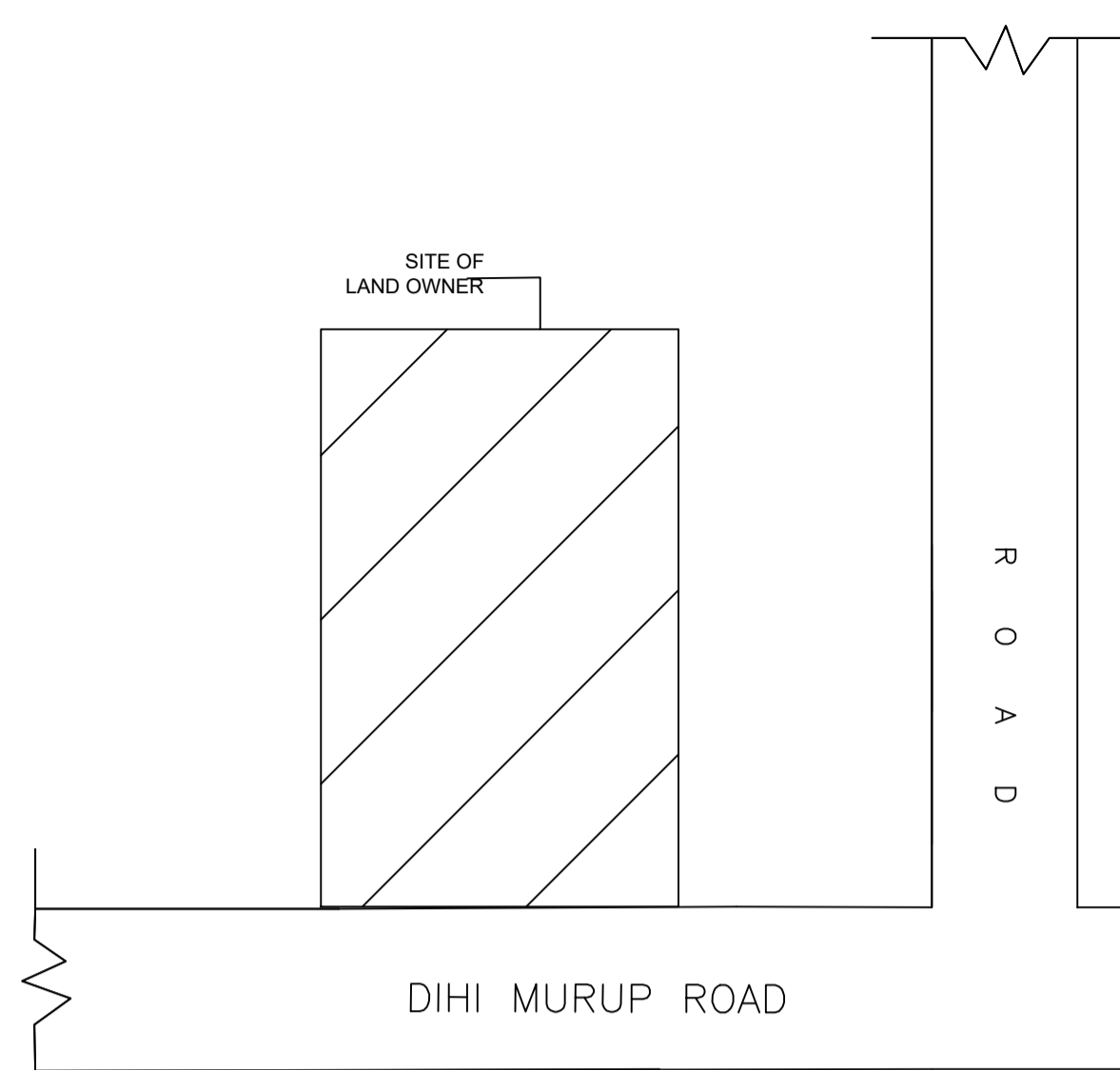

LOCATION PLAN

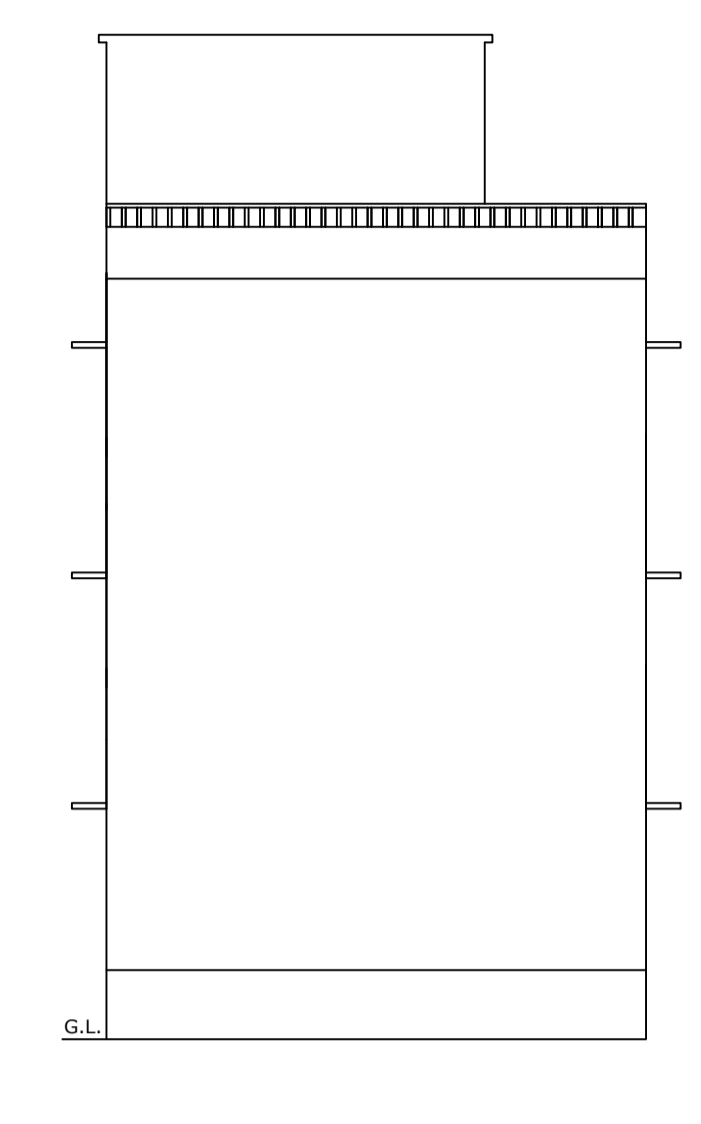

SOUTH SIDE ELEVATION

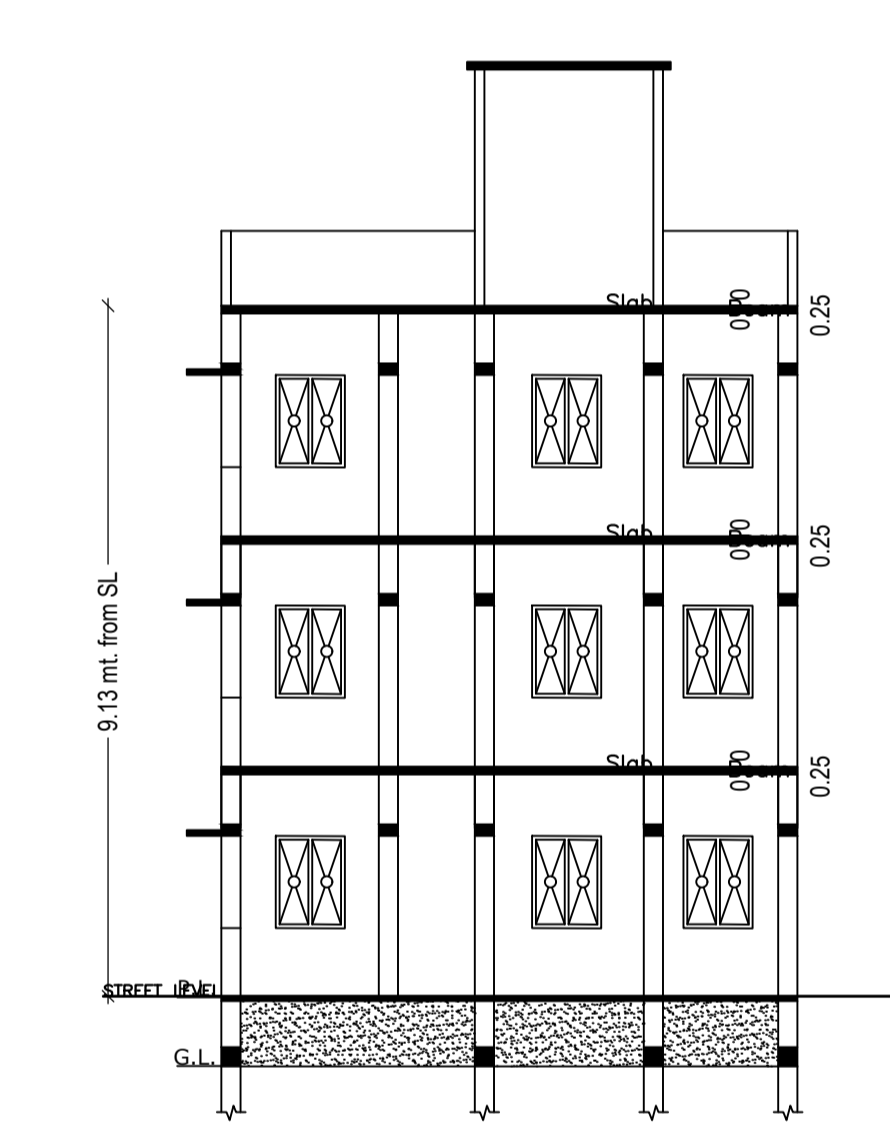

SECTION- YY

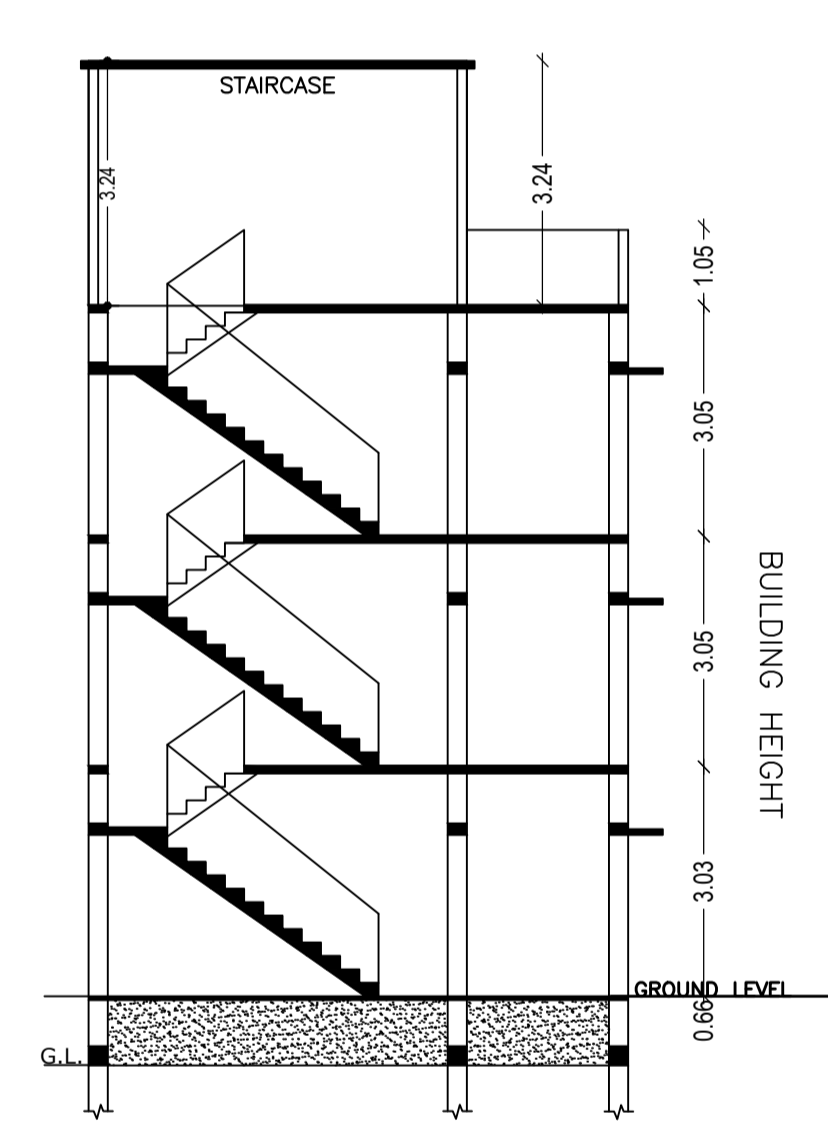

SECTION- XX

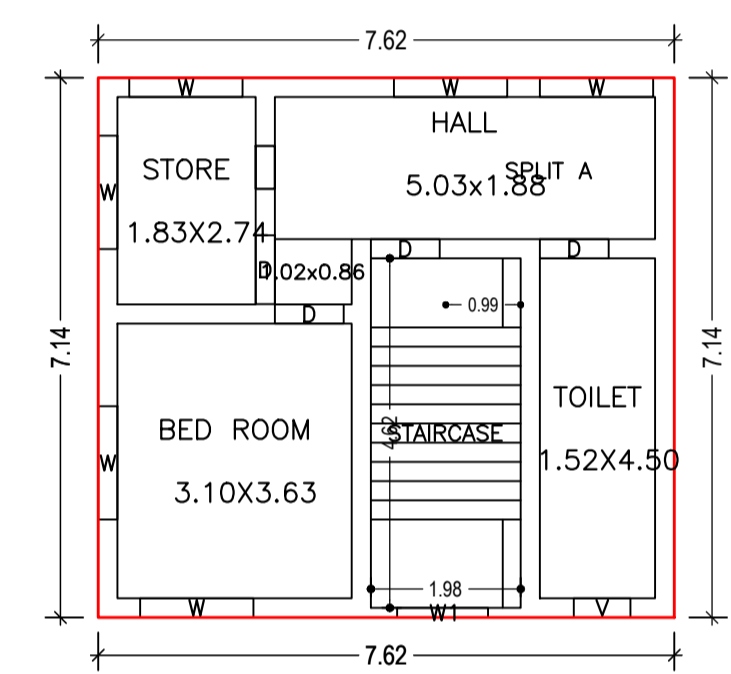

SECOND FLOOR PLAN (Proposed) (SCALE 1:100)

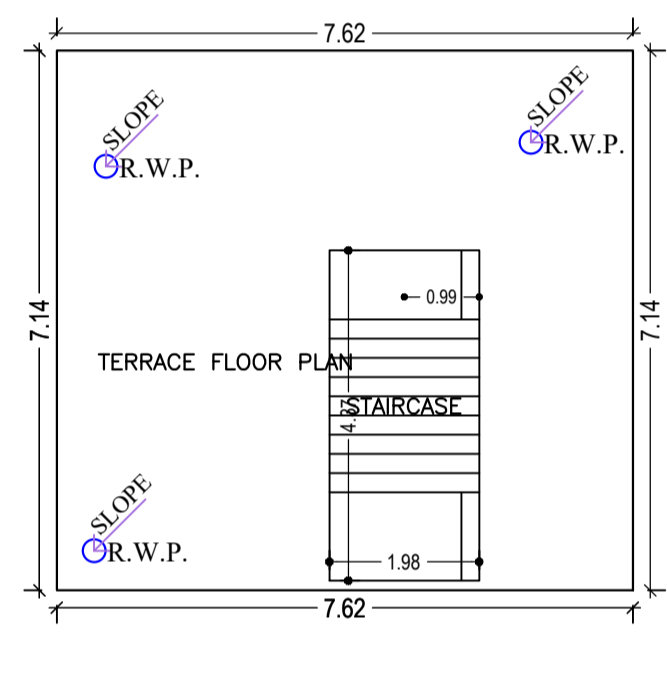

TERRACE FLOOR PLAN (SCALE 1:100)

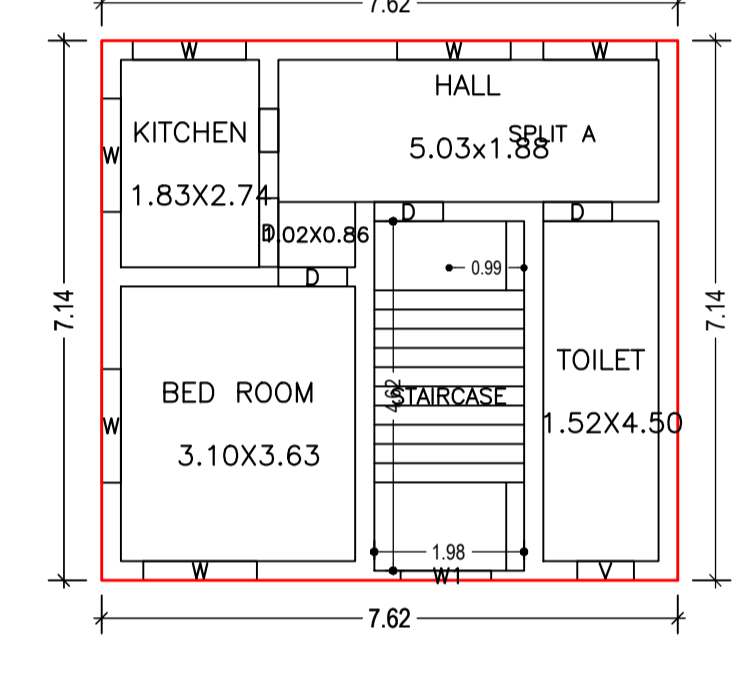

FIRST FLOOR PLAN (Proposed) (SCALE 1:100)

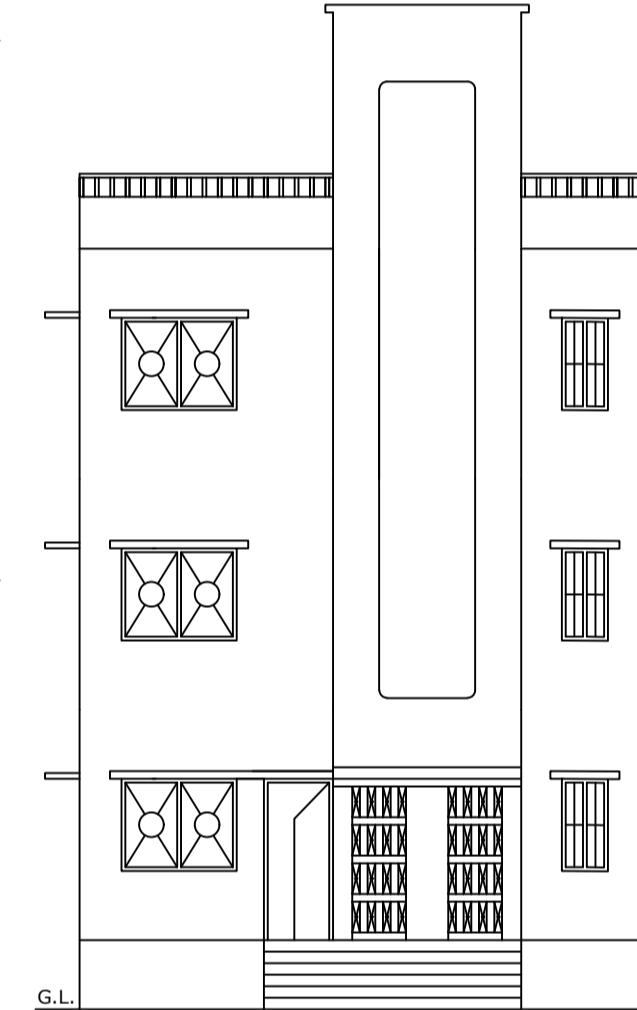

FRONT ELEVATION

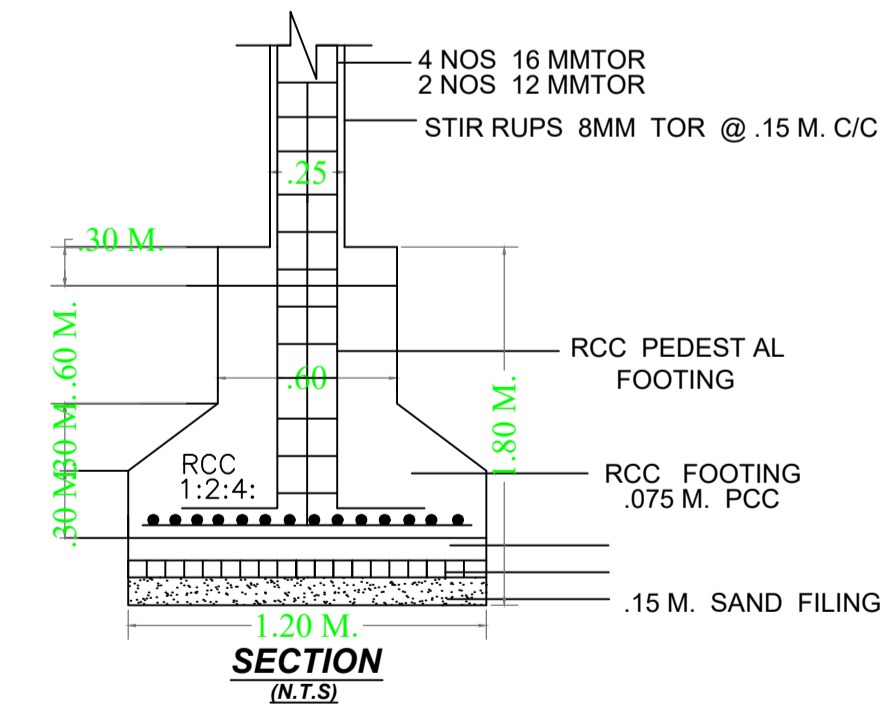

DETAIL OF RAIN WATER HARVESTING AND RECHARGE PIT.(N.T.S.)

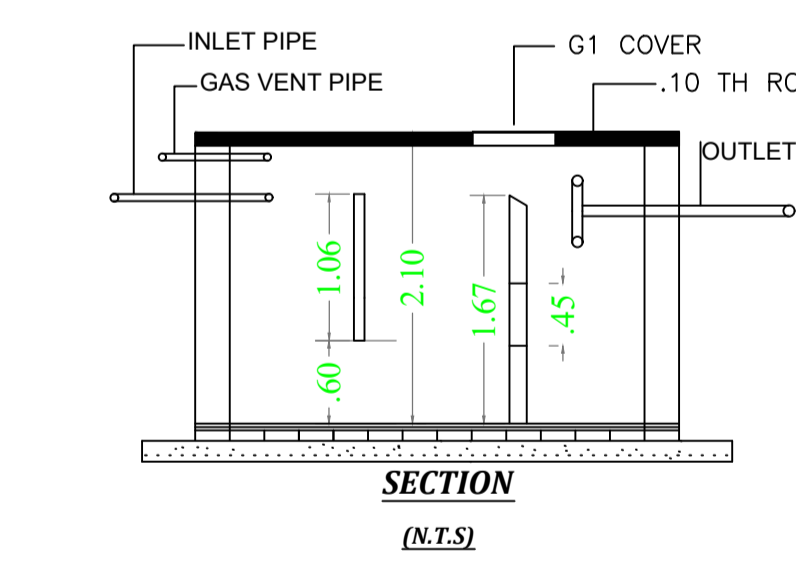

DETAIL OF SEPTIC TANK (N.T.S.)

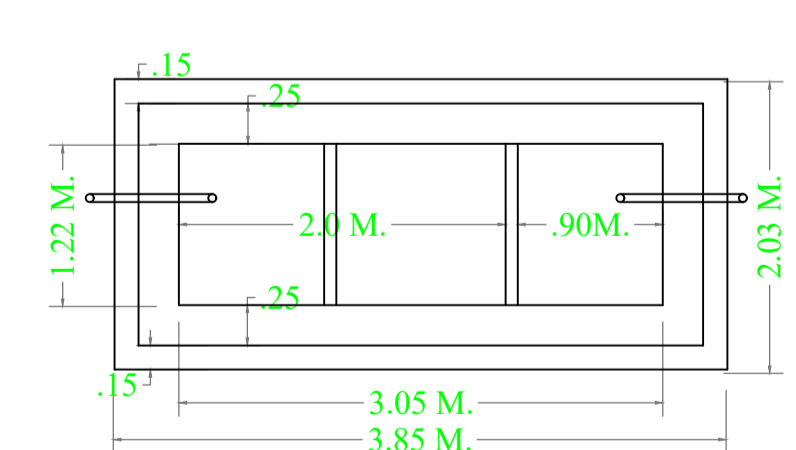

GROUND FLOOR PLAN (SCALE 1:100)

Proposal Basic Information

Proposal File No.	LNPC/BP/0027/W09/2022
Owner Name	Vikash kumar
Khata No	41
Plot No	03
Village Name	Tapaksh
Use	Residential
SubUse	Bungalow/ Dwelling / Non Apartment

AREA STATEMENT LATEHAR NAGAR PANCHAYAT

Version No.	1.0.64	SQ.MT.
Version Date	16/10/2020	
Project Detail:		
Region: JHARKHAND URBAN LOCAL BODIES	Plot Use: Residential	
District: LATEHAR	Plot SubUse: Bungalow/ Dwelling / Non Apartment	
Authority: LATEHAR NAGAR PANCHAYAT	PlotNearbyReligiousStructure: NA	
Inward No: LNPC/BP/0027/W09/2022	Plot/SubPlot No: 03	
Application Type: General Proposal	North: Plot No. - satish kumar	
Project Type: Building Permission	South: Plot No. - dilip kumar	
Nature of Development: New	East: Survey No. - Sabita sahu	
Location of Development Area: Old Area	West: Road Width - 9.10	
AREA OF PLOT (Minimum)	(A)	90.87
NET AREA OF PLOT(Gross Plot Area - Deduction from Gross Plot area)	(A-Deductions)	90.87
Deduction for Balance Plot Area(from Gross Plot Area)		
Common Plot		15.71
Total		15.71
BALANCE AREA OF PLOT(Net Plot Area - Recreational/Amenity space)	(A-Deductions)	75.16
PLOT AREA FOR COVERAGE(Net Plot Area)	(A-Deductions)	90.87
Plot Area for FAR (Net Plot Area + RoadWidening Area)	(A-Deductions)	90.87
COVERAGE CHECK		
Permissible Coverage area (70.00 %)		63.61
Proposed Coverage Area (59.85 %)		54.39
Total Prop. Coverage Area (59.85 %)		54.39
Balance coverage area (10.15 %)		9.22
FAR CHECK		
Perm. FAR Area (1.500)		136.31
Total Perm. FAR area		136.31
Residential FAR		108.77
Proposed FAR Area		117.93
Total Proposed FAR Area		117.93
Consumed FAR (Factor)		1.30
Balance FAR Area		18.38
BUILT UP AREA CHECK		
Total Proposed BuiltUp Area		163.17
ARCHITECT (Regd)	law chaturvedi	
ENGINEER (Regd)		
SUPERVISOR (Regd)		
OWNER (Regd)	Vikash kumar	
DEVELOPMENT AUTHORITY		LOCAL BODY

Building :A (VIKASH KUMAR)

Floor Name	Total Built Up Area (Sq.mt.)	Deductions (Area in Sq.mt.)	Proposed FAR Area (Sq.mt.)	Add Area in FAR (Sq.mt.)	Total FAR Area (Sq.mt.)	Total Consumed Additional FAR Area (Sq.mt.)	Trmt (No.)
Ground Floor	54.39	45.23	0.00	9.16	9.16	9.16	00
First Floor	54.39	0.00	54.39	0.00	54.39	54.39	01
Second Floor	54.39	0.00	54.39	0.00	54.39	54.39	00
Terrace Floor	0.00	0.00	0.00	0.00	0.00	0.00	00
Total:	163.17	45.23	108.78	9.16	117.94	117.94	01
Total Number of Same Buildings	1						
Total:	163.17	45.23	108.78	9.16	117.94	117.94	01

Buildingwise Floor FAR Details

Floor Name	Building Name A (VIKASH KUMAR)		Total	
	Proposed Built Up Area (Sq.mt.)	Proposed FAR Area (Sq.mt.)	Total Proposed Built Up Area (Sq.mt.)	Total FAR Area (Sq.mt.)
Ground Floor	54.39	9.16	54.39	9.16
First Floor	54.39	54.39	54.39	54.39
Second Floor	54.39	54.39	54.39	54.39
Terrace Floor	0.00	0.00	0.00	0.00
Total:	163.17	117.94	163.17	117.94

UnitBUA Table for Building :A (VIKASH KUMAR)

FLOOR	Name	UnitBUA Type	UnitBUA Area	Carpet Area	No. of Rooms	No. of Tenement
SECOND FLOOR PLAN	SPLIT A	FLAT	0.00	0.00	4	0
FIRST FLOOR PLAN	SPLIT A	FLAT	70.65	70.36	4	1
Total:	-	-	70.65	70.36	8	1

FAR & Tenement Details (Table 4c-1)

Building	No. of Same Bldg	Total Built Up Area (Sq.mt.)	Deductions (Area in Sq.mt.)	Proposed FAR Area (Sq.mt.)	Add Area in FAR (Sq.mt.)	Total FAR Area (Sq.mt.)	Total Consumed Additional FAR Area (Sq.mt.)	Trmt (No.)
A (VIKASH KUMAR)	1	163.17	45.23	108.78	9.16	117.94	117.94	01
Grand Total:	1	163.17	45.23	108.78	9.16	117.94	117.94	01

SCHEDULE OF DOOR:

BUILDING NAME	NAME	LENGTH	HEIGHT	NOS
A (VIKASH KUMAR)	D	0.91	2.13	08

SCHEDULE OF WINDOW/VENTILATION:

BUILDING NAME	NAME	LENGTH	HEIGHT	NOS
A (VIKASH KUMAR)	V	0.75	2.70	02
A (VIKASH KUMAR)	W1	1.20	2.70	02
A (VIKASH KUMAR)	W	1.50	2.70	12

Building USE/SUBUSE Details

Building Name	Building Use	Building SubUse	Building Structure
A (VIKASH KUMAR)	Residential	Bungalow/ Dwelling / Non Apartment	Non-Highrise

COLOR INDEX

FLAT	Green
COMMON PLOT	Red
EXISTING (To be retained)	Blue
EXISTING (To be demolished)	Yellow

LTP NAME AND SIGNATURE: law chaturvedi
LNPC/ENG/0004/2018

LTP NAME AND SIGNATURE	STRUCTURAL ENG'S NAME AND SIGNATURE	BUILDER NAME AND SIGNATURE	DIGITAL SIGNATURE
law chaturvedi LNPC/ENG/0004/2018			