

PLOT NO. - 207 &
KAMESHWAR PRASAD
11.89 mt.

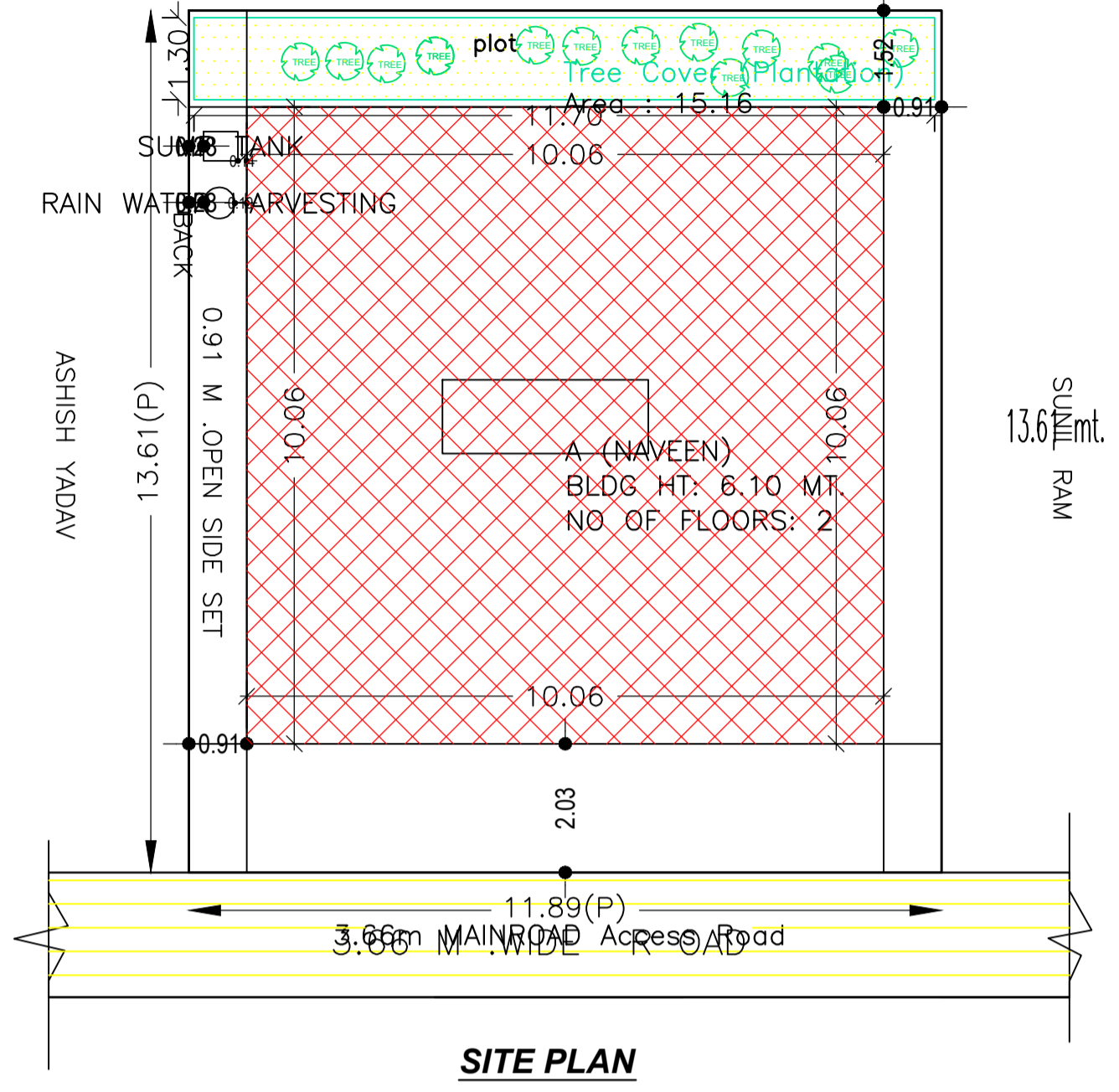

SITE PLAN

FAR & Tenement Details (Table 4c-1)

Building	No. of Same Bldg	Total Built Up Area (Sq.mt.)	Proposed FAR Area (Sq.mt.)	Total FAR Area (Sq.mt.)	Total Consumed Additional FAR Area (Sq.mt.)	Tnmt (No.)
A (NAVEEN)	1	202.34	202.34	202.34	202.34	01
Grand Total:	1	202.34	202.34	202.34	202.34	01

Proposal Basic Information

Proposal File No.	LNPC/BP/0019/W12/2023
Owner Name	NAVIN KUMAR SINHA
Khata No	27
Plot No	208
Village Name	Dhampur
Use	Residential
SubUse	Bungalow/ Dwelling / Non Apartment

AREA STATEMENT LATEHAR NAGAR PANCHAYAT		VERSION NO: 1.0.66
PROJECT DETAIL:		VERSION DATE: 16/10/2020
Region: JHARKHAND URBAN LOCAL BODIES	Plot Use: Residential	
District: LATEHAR	Plot SubUse: Bungalow/ Dwelling / Non Apartment	
Authority: LATEHAR NAGAR PANCHAYAT	PlotNearbyReligiousStructure: NA	
Inward No: LNPCI/BP/0019/W12/2023	Plot/SubPlot No: 208	
Application Type: General Proposal	North: Survey No. - SUNIL RAM	
Project Type: Building Permission	South: Plot No. - ASHIS YEDAV	
Nature of Development: New	East: Road Width - 3.66	
Location of Development Area: Old Area	West: Plot No. - KAMESHWAR PRASAD	
AREA DETAILS:		
AREA OF PLOT (Minimum)	(A)	SQ.MT. 161.82
NET AREA OF PLOT(Gross Plot Area - Deduction from Gross Plot area)	(A-Deductions)	161.82
Deduction for Balance Plot Area(from Gross Plot Area)		
Common Plot		15.16
Total		15.16
BALANCE AREA OF PLOT(Net Plot Area - Recreational/Amenity space)	(A-Deductions)	146.66
PLOT AREA FOR COVERAGE(Net Plot Area)	(A-Deductions)	161.82
Plot Area for FAR (Net Plot Area + Road Widening Area)	(A-Deductions)	161.82
COVERAGE CHECK		
Permissible Coverage area (70.00 %)		113.27
Proposed Coverage Area (62.52 %)		101.17
Total Prop. Coverage Area (62.52 %)		101.17
Balance coverage area (7.48 %)		12.10
FAR CHECK		
Perm. FAR Area (1.500)		242.73
Total Perm. FAR area		242.73
Residential FAR		202.34
Proposed FAR Area		202.34
Total Proposed FAR Area		202.34
Consumed FAR (Factor)		1.25
Balance FAR Area		40.39
BUILT UP AREA CHECK		
Total Proposed BuiltUp Area		202.34
ARCHITECT (Regd)		law chaturvedi
ENGINEER (Regd)		
SUPERVISOR (Regd)		
OWNER (Regd)		NAVIN KUMAR SINHA
DEVELOPMENT AUTHORITY		LOCAL BODY

COLOR INDEX	
PLOT BOUNDARY	Black
ABUTTING ROAD	Green
PROPOSED CONSTRUCTION	Red
COMMON PLOT	Yellow
ROAD WIDENING AREA	Blue
EXISTING (To be retained)	Light Blue
EXISTING (To be demolished)	Light Yellow

Buildingwise Floor FAR Details

Floor Name	Building Name		Total	
	Proposed Built Up Area (Sq.mt.)	Proposed FAR Area (Sq.mt.)	Total Proposed Built Up Area (Sq.mt.)	Total FAR Area (Sq.mt.)
Ground Floor	101.17	101.17	101.17	101.17
First Floor	101.17	101.17	101.17	101.17
Terrace Floor	0.00	0.00	0.00	0.00
Total :	202.34	202.34	202.34	202.34

Building USE/SUBUSE Details

Building Name	Building Use	Building SubUse	Building Structure
A (NAVEEN)	Residential	Bungalow/ Dwelling / Non Apartment	Non-Highrise

LTP NAME AND SIGNATURE	STRUCTURAL ENG'S NAME AND SIGNATURE	BUILDER NAME AND SIGNATURE	DIGITAL SIGNATURE
law chaturvedi LNPCI/ENG/0004/2018			

Proposal Basic Information	
Proposal File No.	LNPC/BP/0019/W12/2023
Owner Name	NAVIN KUMAR SINHA
Khata No	27
Plot No	208
Village Name	Dhampur
Use	Residential
SubUse	Bungalow/ Dwelling / Non Apartment

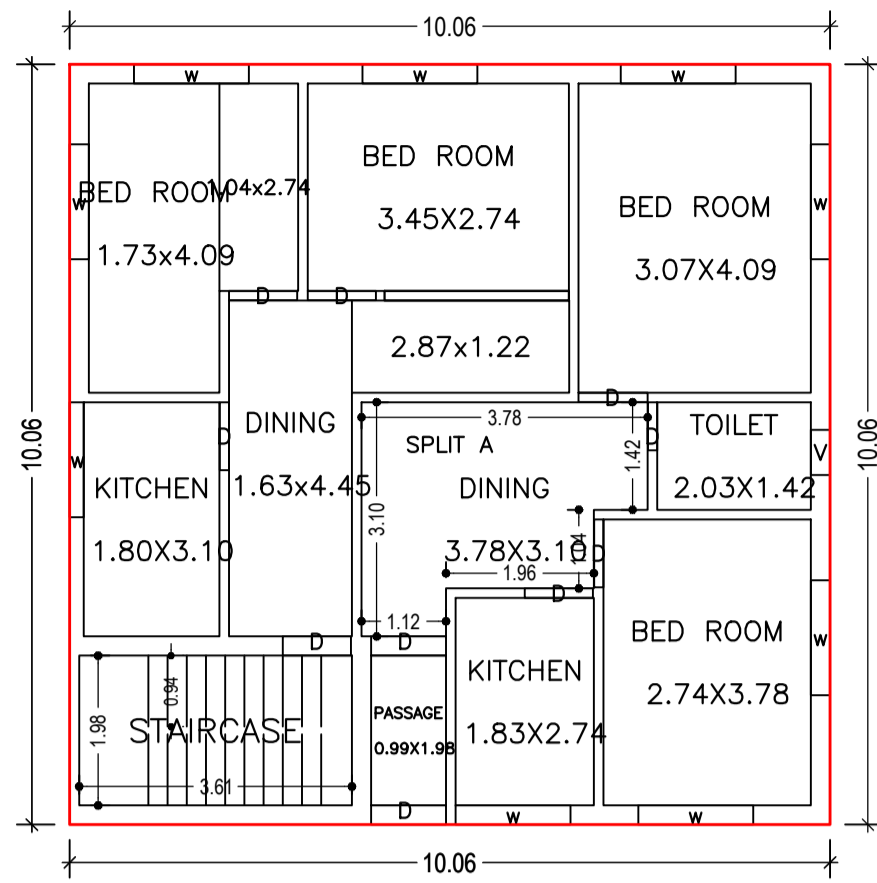

GROUND FLOOR PLAN (Proposed) (SCALE 1:100)

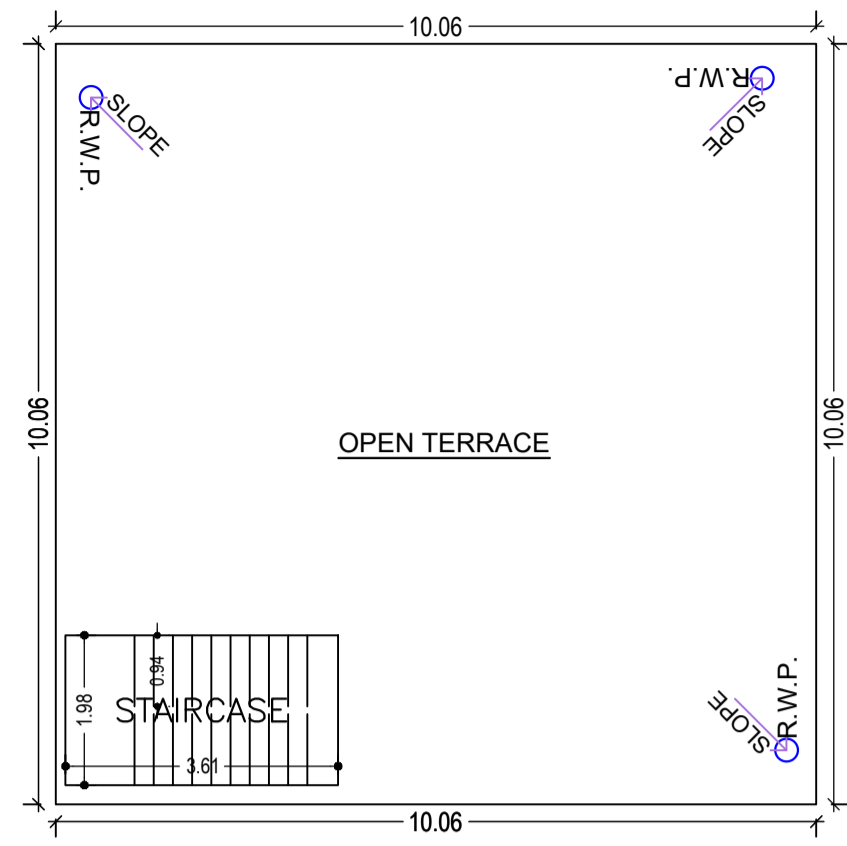

TERRACE FLOOR PLAN (SCALE 1:100)

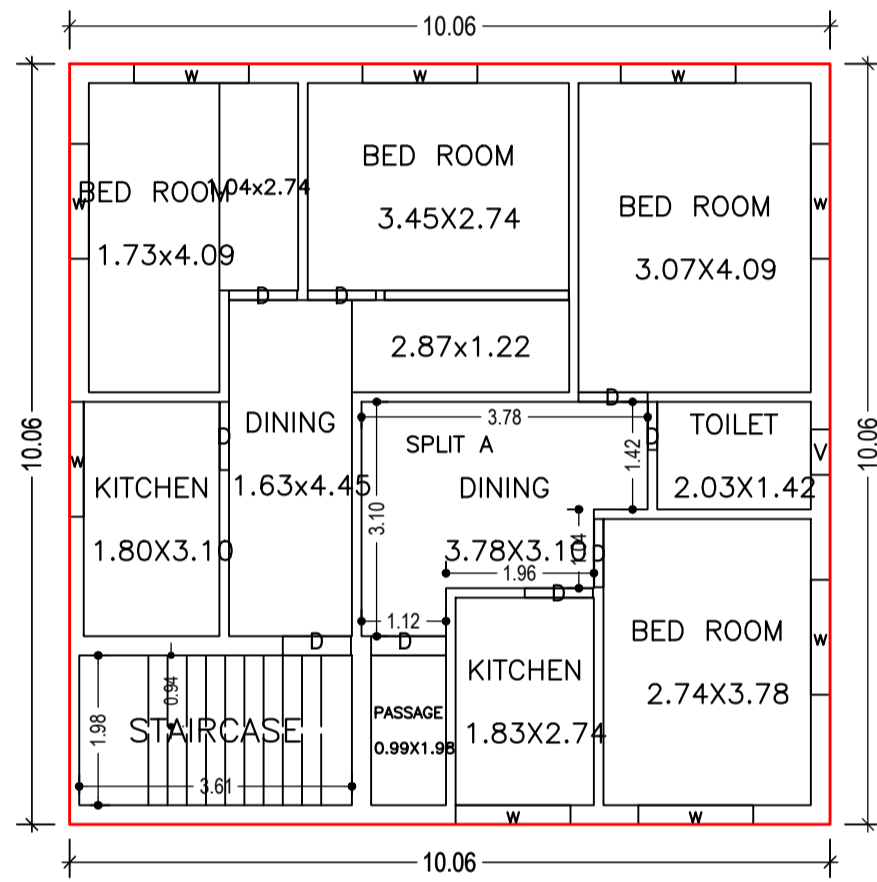

FIRST FLOOR PLAN (Proposed) (SCALE 1:100)

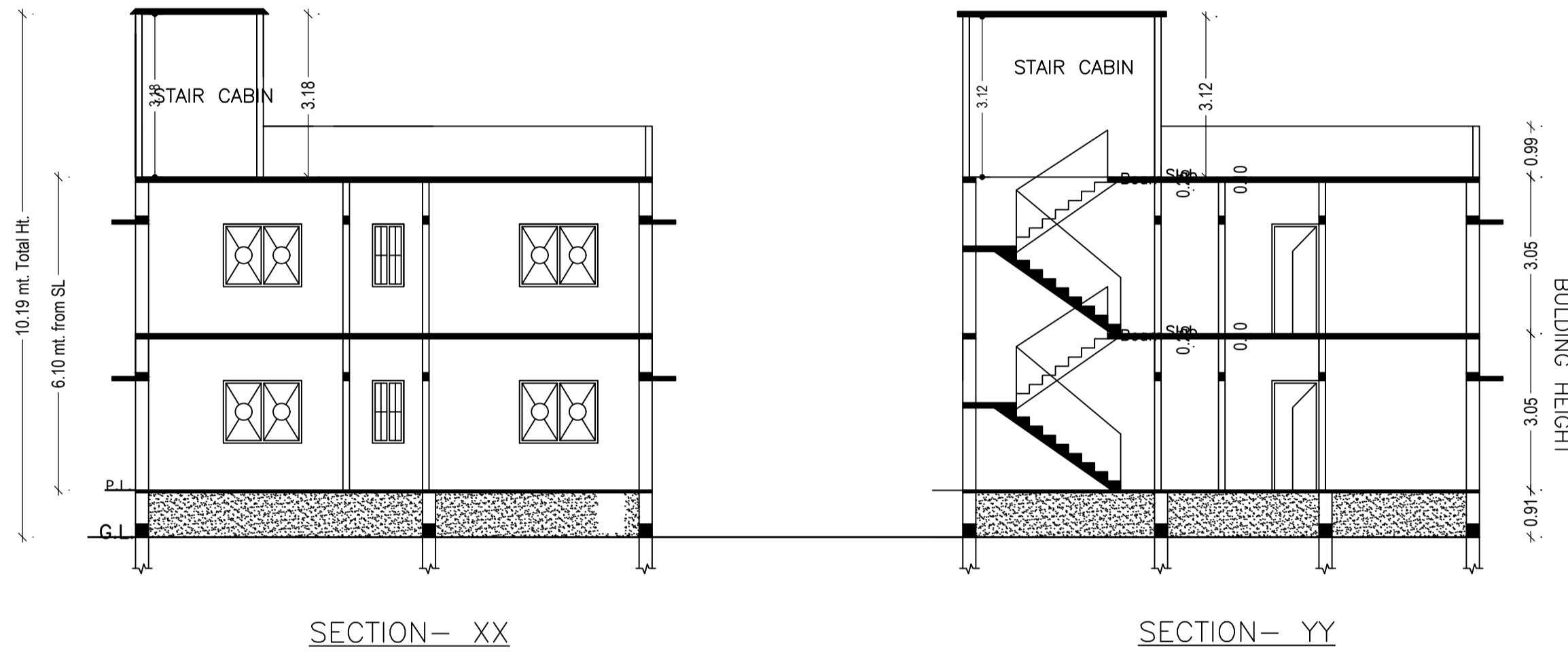

SECTION- XX

SECTION- YY

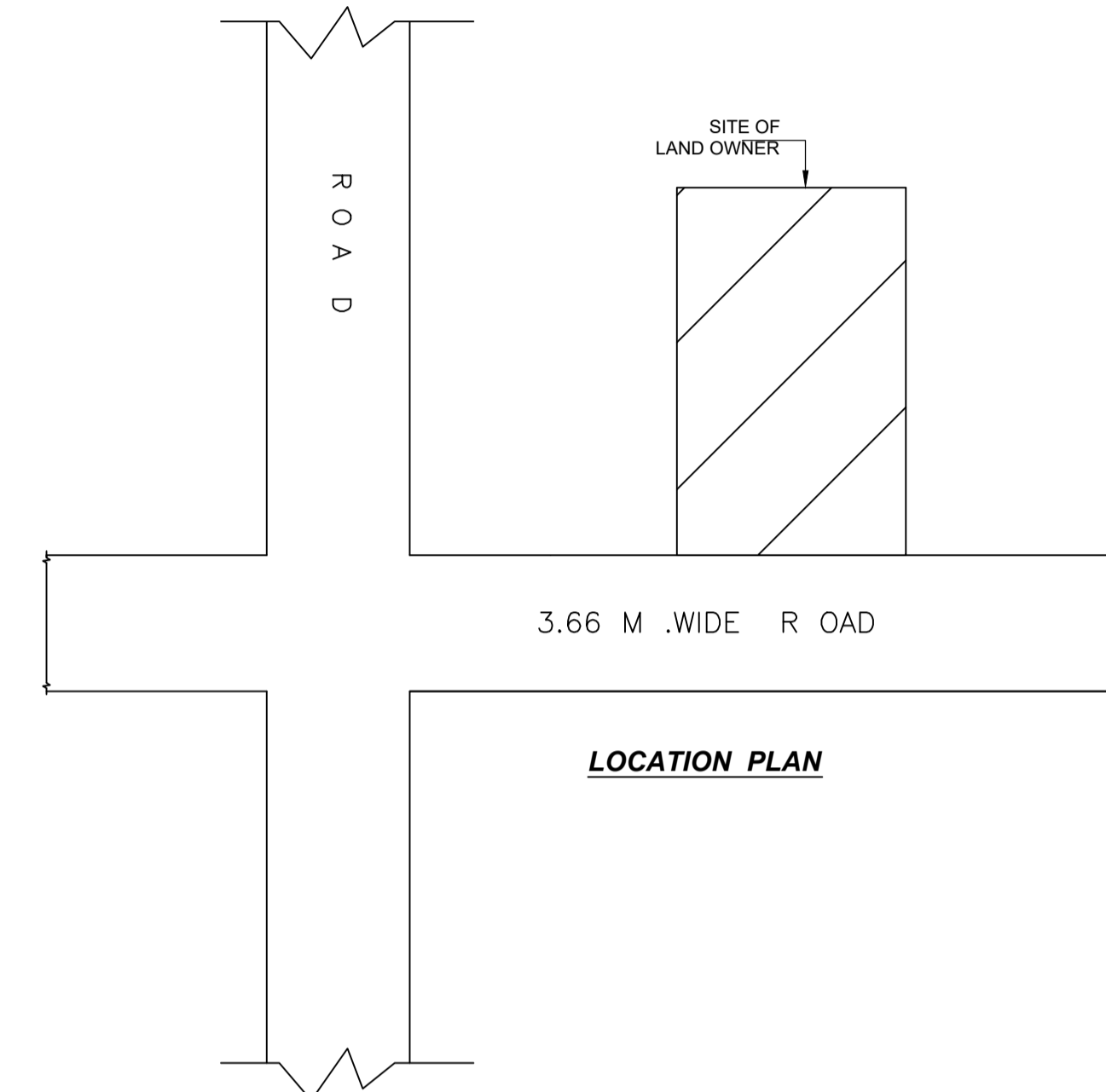

LOCATION PLAN

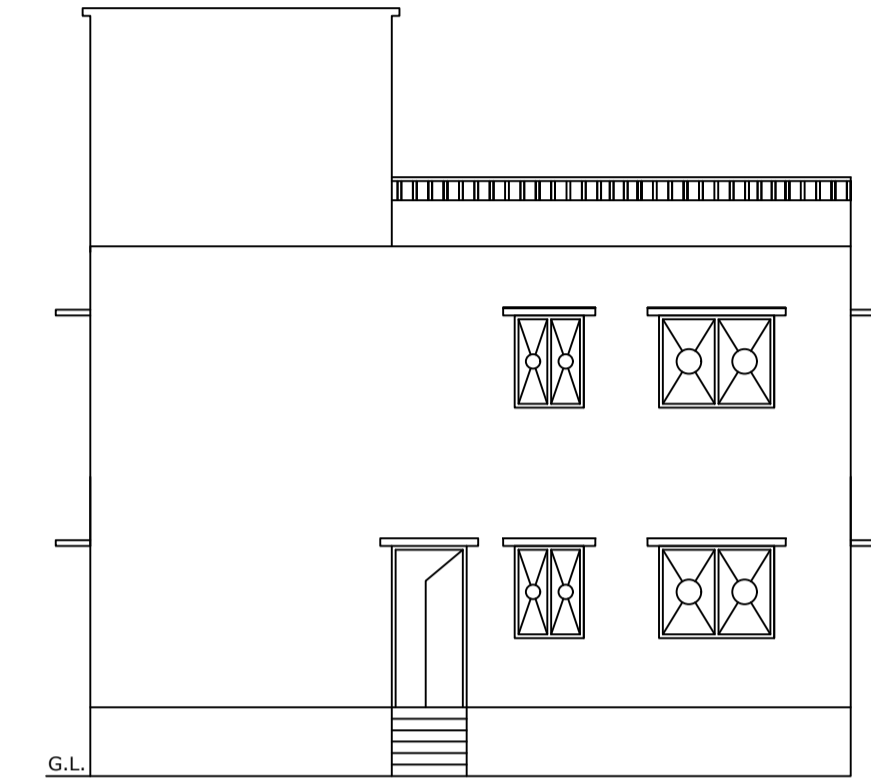

FRONT ELEVATION

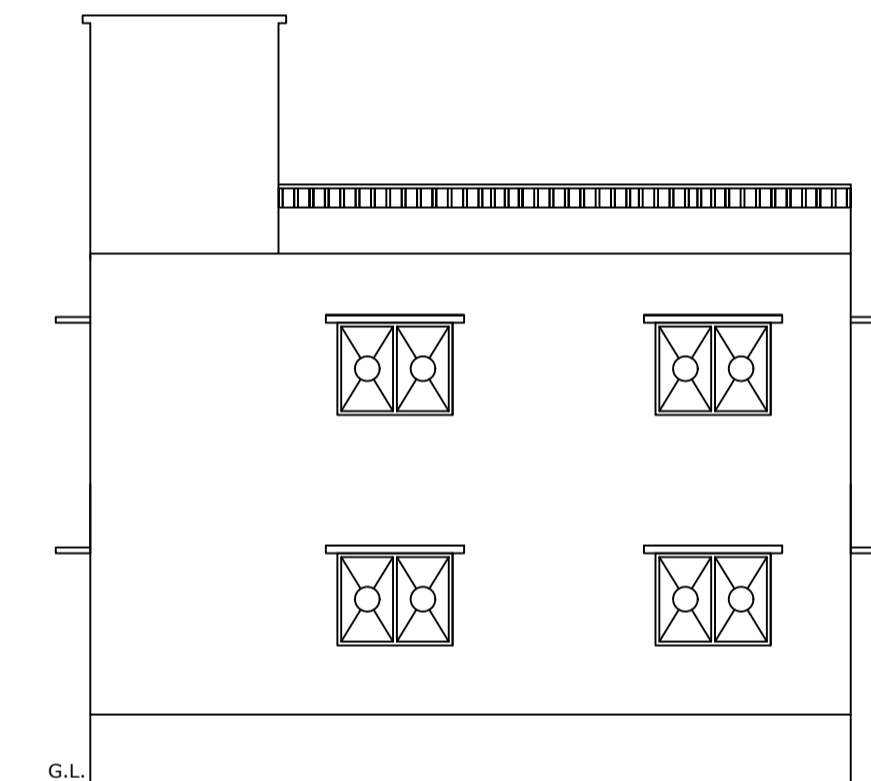

SOUTH SIDE ELEVATION

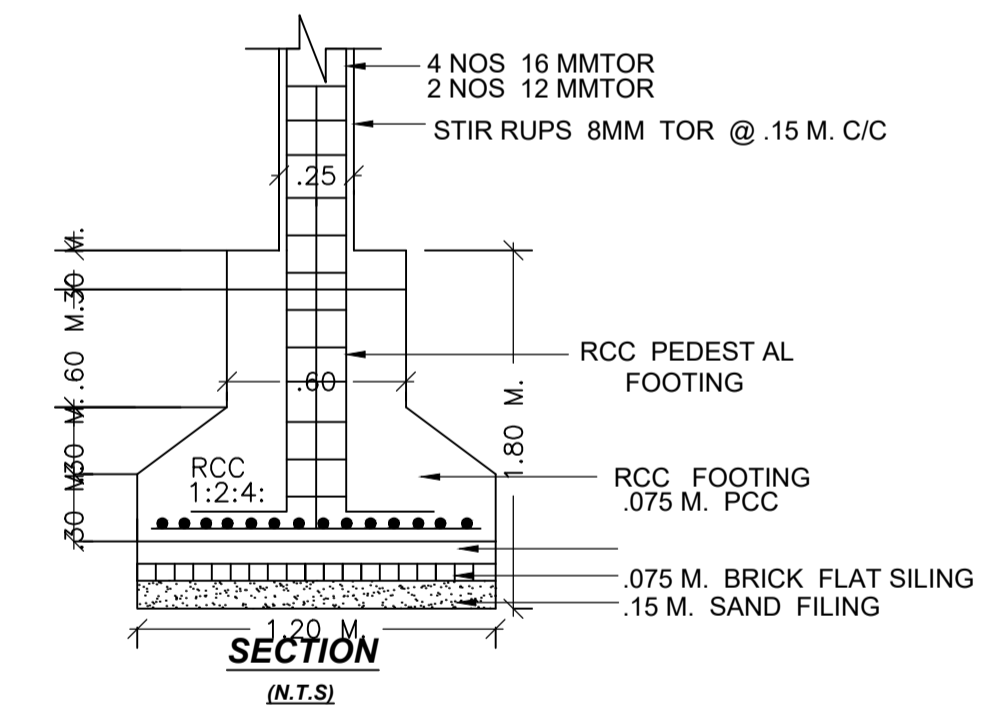

SECTION (N.T.S)

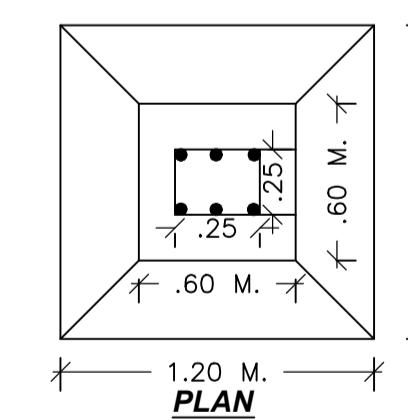

PLAN

Building :A (NAVEEN)

Floor Name	Total Built Up Area (Sq.mt.)	Proposed FAR Area (Sq.mt.) Resi.	Total FAR Area (Sq.mt.)	Total Consumed Additional FAR Area (Sq.mt.)	Tnmt (No.)
Ground Floor	101.17	101.17	101.17	101.17	01
First Floor	101.17	101.17	101.17	101.17	00
Terrace Floor	0.00	0.00	0.00	0.00	00
Total :	202.34	202.34	202.34	202.34	01
Total Number of Same Buildings	1				
Total :	202.34	202.34	202.34	202.34	01

SCHEDULE OF DOOR:

BUILDING NAME	NAME	LENGTH	HEIGHT	NOS
A (NAVEEN)	D	0.64	2.10	02
A (NAVEEN)	D	0.90	2.10	12
A (NAVEEN)	D	0.91	2.10	02
A (NAVEEN)	D	0.99	2.10	03

SCHEDULE OF WINDOW/VENTILATION:

BUILDING NAME	NAME	LENGTH	HEIGHT	NOS
A (NAVEEN)	V	0.60	0.60	02
A (NAVEEN)	w	1.52	1.20	18

UnitBUA Table for Building :A (NAVEEN)

FLOOR	Name	UnitBUA Type	UnitBUA Area	Carpet Area	No. of Rooms	No. of Tenement
FIRST FLOOR PLAN	SPLIT A	FLAT	0.00	0.00	10	0
GROUND FLOOR PLAN	SPLIT A	FLAT	166.16	165.54	10	1
Total:	-	-	166.16	165.54	20	1

LTP NAME AND SIGNATURE	STRUCTURAL ENG'S NAME AND SIGNATURE	BUILDER NAME AND SIGNATURE	DIGITAL SIGNATURE
law chaturvedi LNPC/ENG/0004/2018			

Proposal Basic Information

Proposal File No.	LNPC/BP/0019/W12/2023
Owner Name	NAVIN KUMAR SINHA
Khata No	27
Plot No	208
Village Name	Dhampur
Use	Residential
SubUse	Bungalow/ Dwelling / Non Apartment

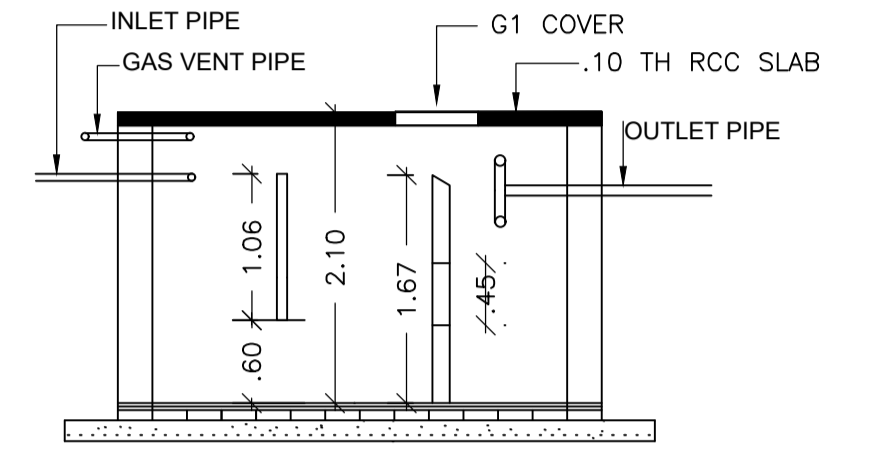

SECTION
(N.T.S)

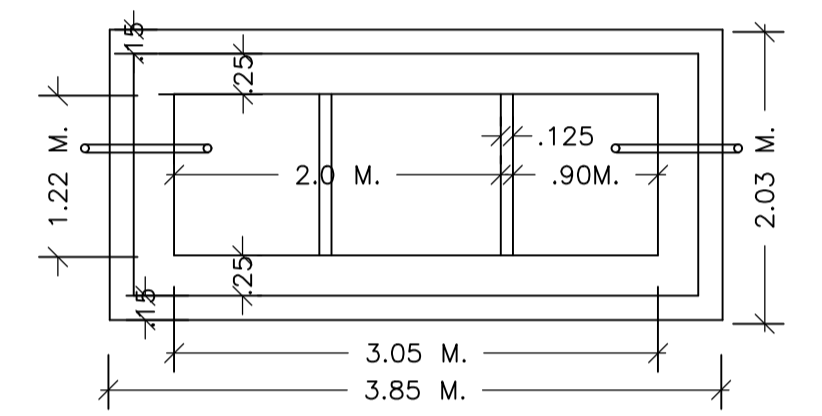

PLAN
DETAIL OF SEPTIC TANK

LTP NAME AND SIGNATURE	STRUCTURAL ENG'S NAME AND SIGNATURE	BUILDER NAME AND SIGNATURE	DIGITAL SIGNATURE
law chaturvedi LNPC/ENG/0004/2018			