

SITE PLAN

FAR & Tenement Details (Table 4c-1)

Building	No. of Same Bldg	Total Built Up Area (Sq.mt.)	Deductions (Area in Sq.mt.)		Proposed FAR Area (Sq.mt.)	Total FAR Area (Sq.mt.)	Total Consumed Additional FAR Area (Sq.mt.)	Trmnt (No.)
			Parking	Resi.				
A (RAMESHWAR)	1	295.02	52.93		242.09	242.09	242.09	01
Grand Total :	1	295.02	52.93		242.09	242.09	242.09	01

Proposal Basic Information

Proposal File No.	LNPC/ENG/0004/2018
Owner Name	Rameshwar Prasad
Khata No	249
Plot No	785/10/0
Village Name	Latehar
Use	Residential
SubUse	Bungalow/ Dwelling / Non Apartment

AREA STATEMENT LATEHAR NAGAR PANCHAYAT		VERSION NO. : 1.0.66
PROJECT DETAIL		VERSION DATE: 16/10/2020
Region: JHARKHAND URBAN LOCAL BODIES	Plot Use: Residential	
District: LATEHAR	Plot SubUse: Bungalow/ Dwelling / Non Apartment	
Authority: LATEHAR NAGAR PANCHAYAT	PlotNearbyReligiousStructure: NA	
Inward No: LNPCI/BP/0025/W07/2023	Plot/SubPlot No: 785/10/0	
Application Type: General Proposal	North: Road Width - 9.15	
Project Type: Building Permission	South: Survey No. - RASTA	
Nature of Development: New	East: Plot No. - ANIL KUMAR PRASAD	
Location of Development Area: Old Area	West: Plot No. - RAMESHWAR PRASAD VENDEE	
AREA DETAILS:		
AREA OF PLOT (Minimum)	(A)	161.76
NET AREA OF PLOT(Gross Plot Area - Deduction from Gross Plot area)	(A-Deductions)	161.76
Deduction for Balance Plot Area(from Gross Plot Area)		
Common Plot		12.68
Total		12.68
BALANCE AREA OF PLOT(Net Plot Area - Recreational/Amenity space)	(A-Deductions)	149.08
PLOT AREA FOR COVERAGE(Net Plot Area)	(A-Deductions)	161.76
Plot Area for FAR (Net Plot Area + Road Widening Area)	(A-Deductions)	161.76
COVERAGE CHECK		
Permissible Coverage area ( 70.00 % )		113.23
Proposed Coverage Area ( 60.79 % )		98.34
Total Prop. Coverage Area ( 60.79 % )		98.34
Balance coverage area ( 9.20 % )		14.89
FAR CHECK		
Perm. FAR Area ( 1.500 )		242.64
Total Perm. FAR area		242.64
Residential FAR		242.08
Proposed FAR Area		242.08
Total Proposed FAR Area		242.08
Consumed FAR (Factor)		1.50
Balance FAR Area		0.56
BUILT UP AREA CHECK		
Total Proposed BuiltUp Area		295.02
ARCHITECT (Regd)		law chaturvedi
ENGINEER (Regd)		
SUPERVISOR (Regd)		
OWNER (Regd)		Rameshwar Prasad
DEVELOPMENT AUTHORITY		LOCAL BODY

COLOR INDEX	
PLOT BOUNDARY	Black
ABUTTING ROAD	Green
PROPOSED CONSTRUCTION	Red
COMMON PLOT	Yellow
ROAD WIDENING AREA	Blue
EXISTING (To be retained)	Light Blue
EXISTING (To be demolished)	Light Yellow

Buildingwise Floor FAR Details

Floor Name	Building Name A (RAMESHWAR)		Total	
	Proposed Built Up Area (Sq.mt.)	Proposed FAR Area (Sq.mt.)	Total Proposed Built Up Area (Sq.mt.)	Total FAR Area (Sq.mt.)
Ground Floor	98.34	45.41	98.34	45.41
First Floor	98.34	98.34	98.34	98.34
Second Floor	98.34	98.34	98.34	98.34
Terrace Floor	0.00	0.00	0.00	0.00
Total :	295.02	242.09	295.02	242.09

Building USE/SUBUSE Details

Building Name	Building Use	Building SubUse	Building Structure
A (RAMESHWAR)	Residential	Bungalow/ Dwelling / Non Apartment	Non-Highrise

LTP NAME AND SIGNATURE	STRUCTURAL ENG'S NAME AND SIGNATURE	BUILDER NAME AND SIGNATURE	DIGITAL SIGNATURE
law chaturvedi LNPCI/ENG/0004/2018			

Proposal Basic Information	
Proposal File No.	LNP/TE/0025/W07/2023
Owner Name	Rameshwar Prasad
Khata No	249
Plot No	785/10/0
Village Name	Latehar
Use	Residential
SubUse	Bungalow/ Dwelling / Non Apartment

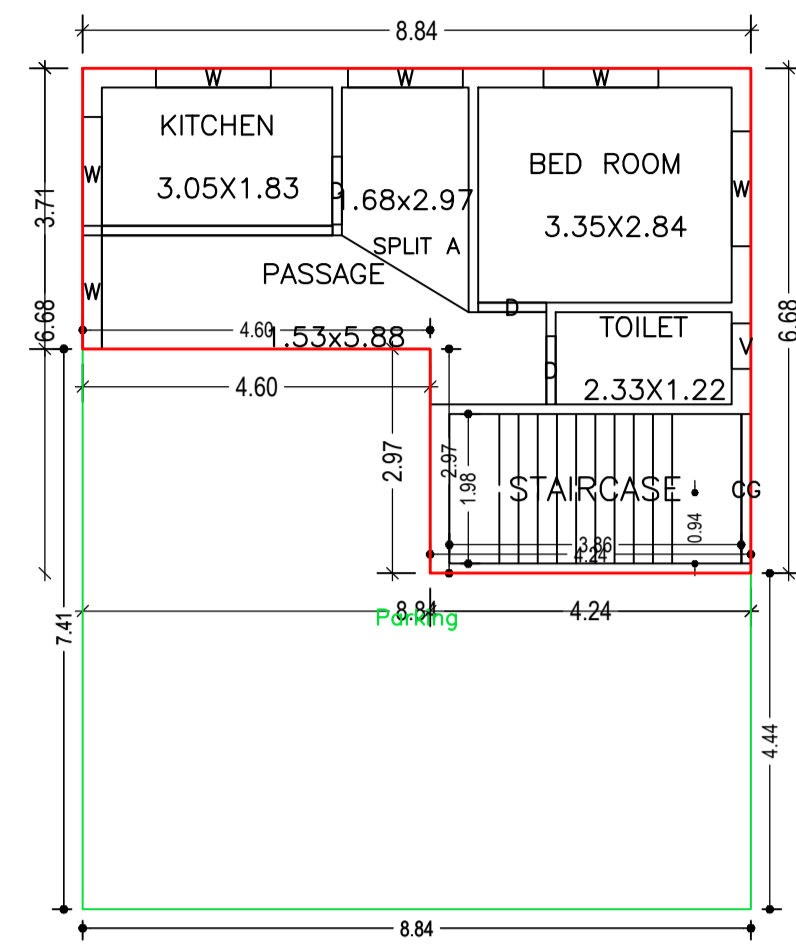

GROUND FLOOR PLAN  
(Proposed)  
(SCALE 1:100)

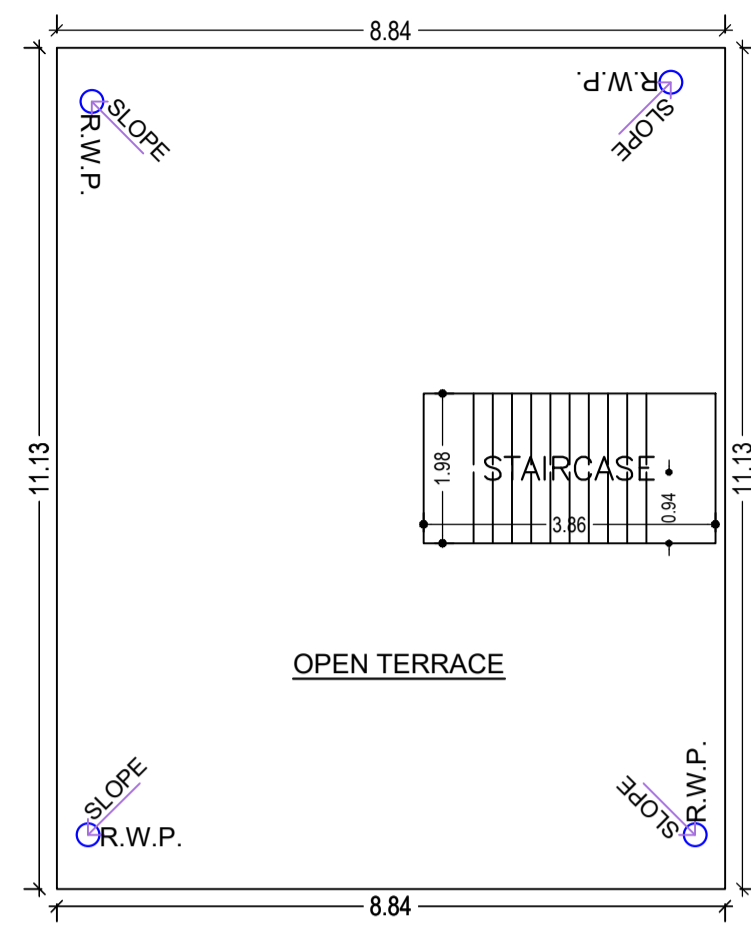

TERRACE FLOOR PLAN  
(SCALE 1:100)

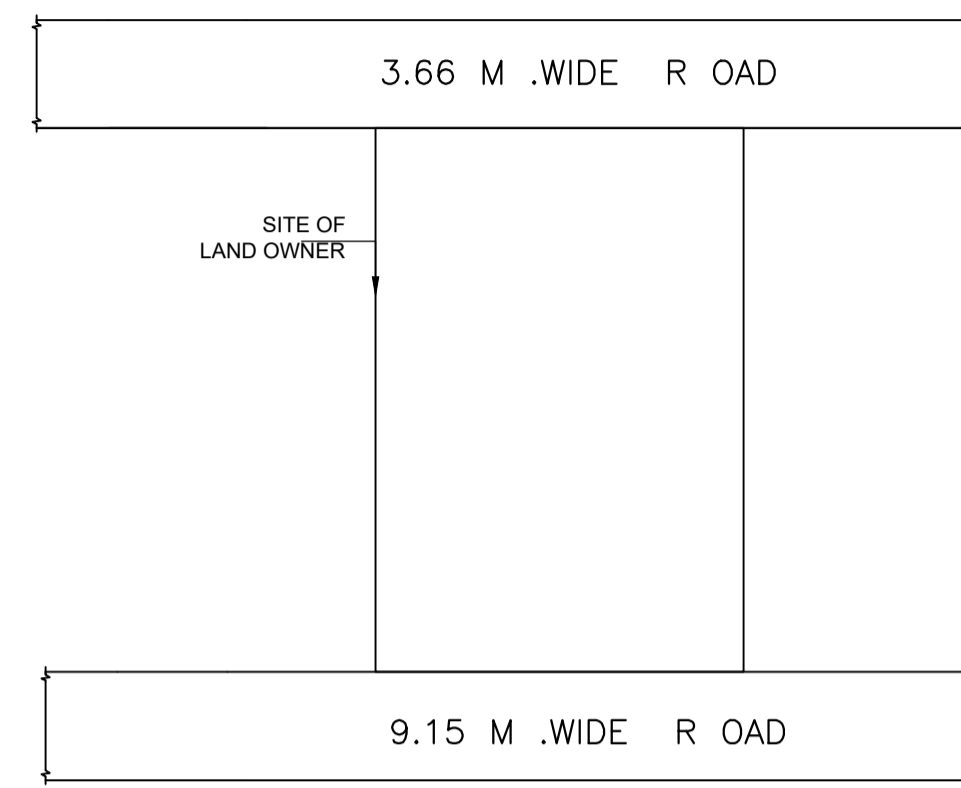

LOCATION PLAN

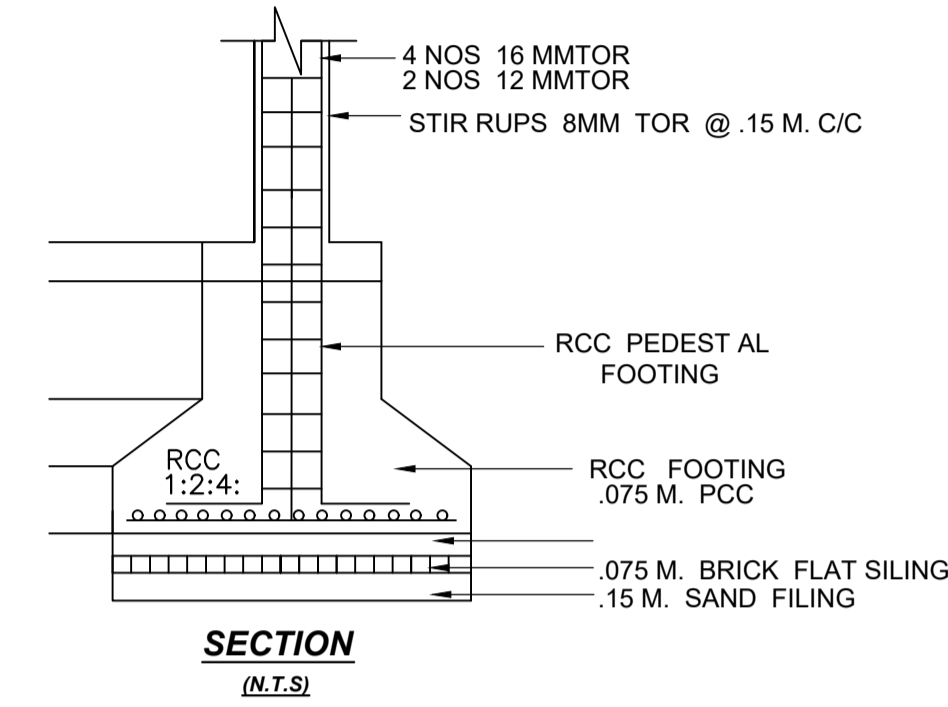

SECTION  
(N.T.S)

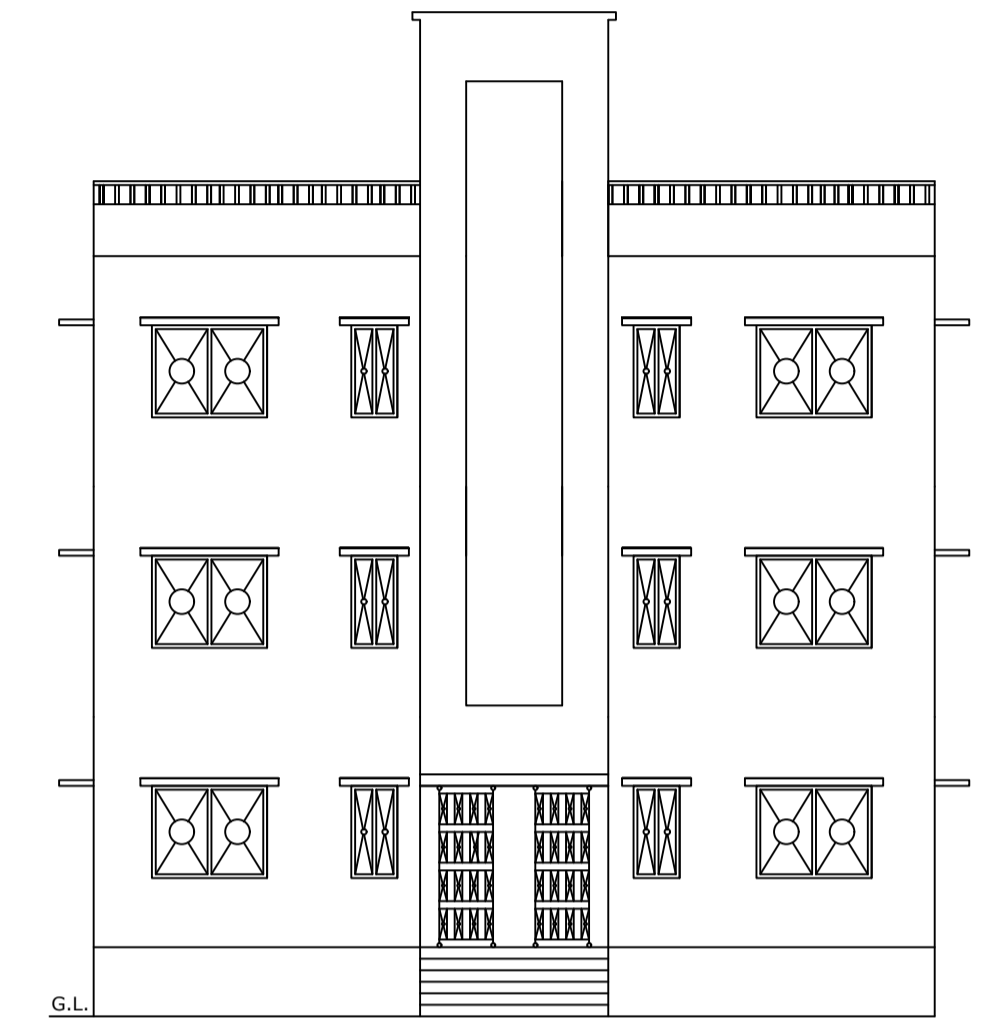

WEST SIDE ELEVATION

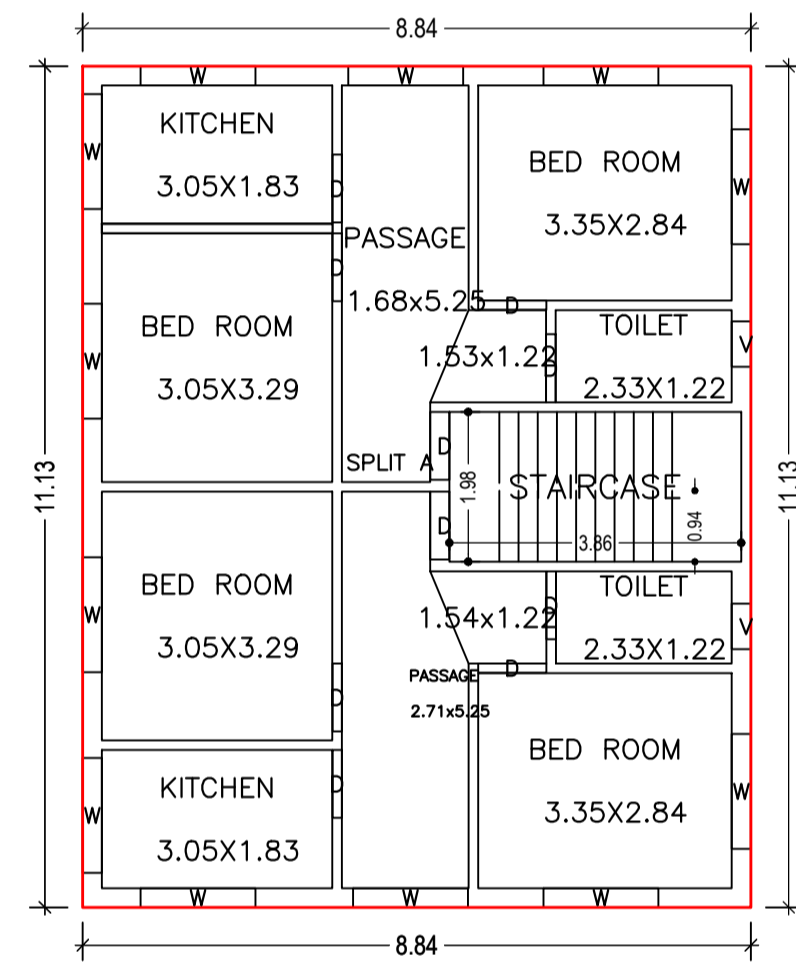

TYPICAL - 1 & 2 FLOOR PLAN  
(Proposed)  
(SCALE 1:100)

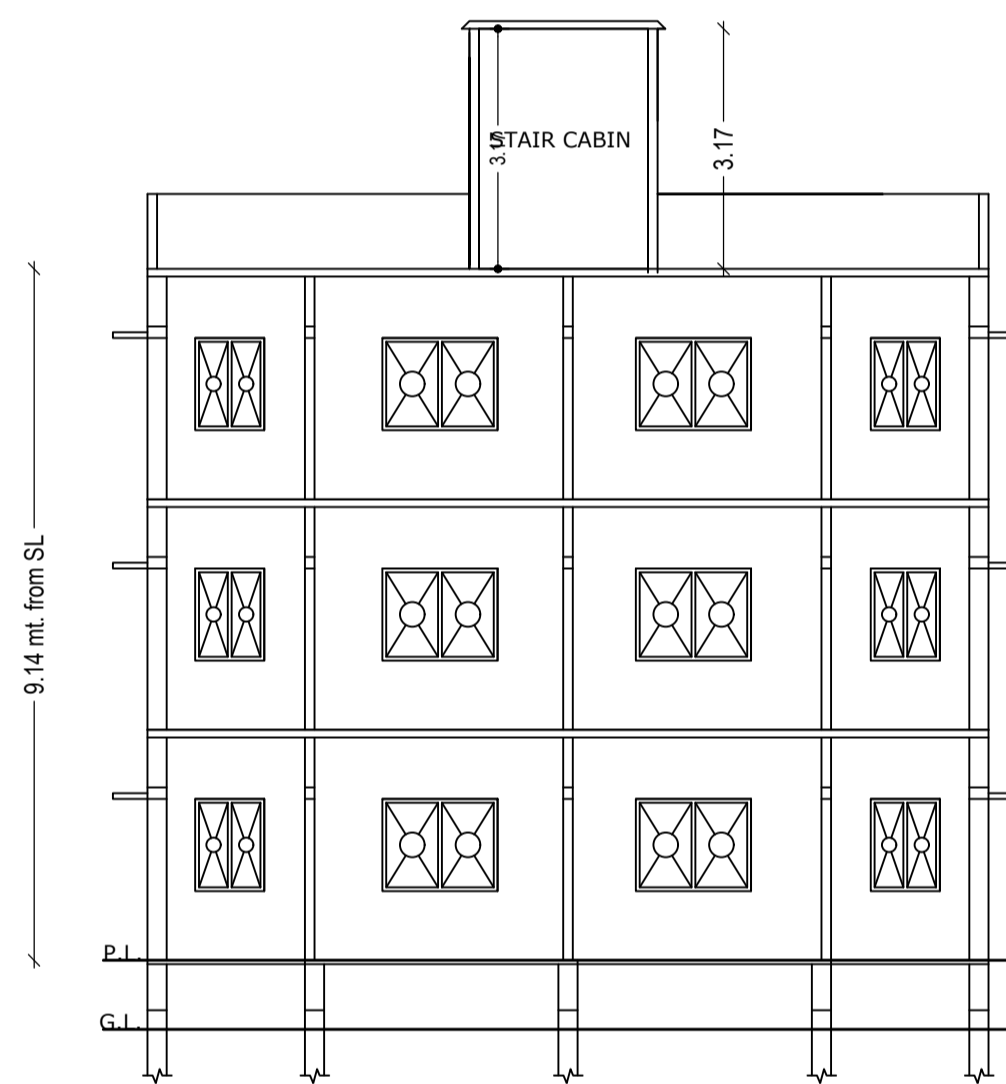

SECTION - XX

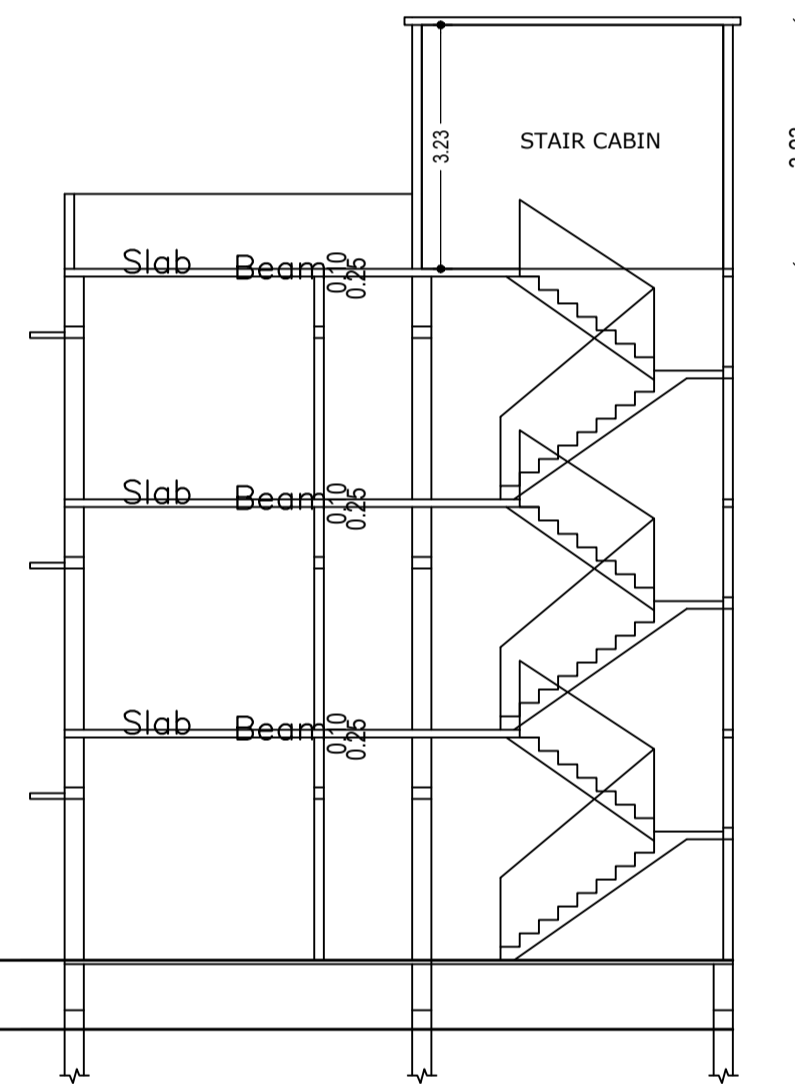

SECTION - YY

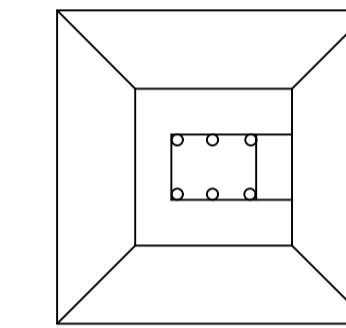

PLAN

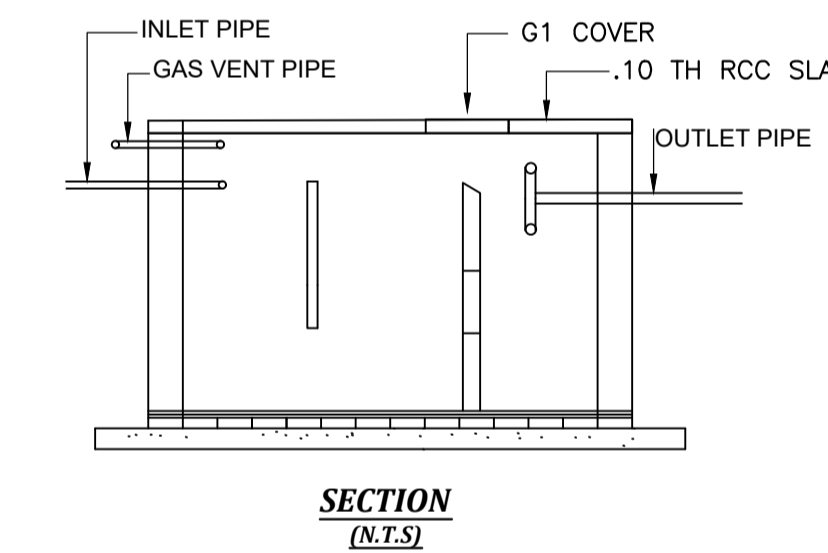

SECTION  
(N.T.S)

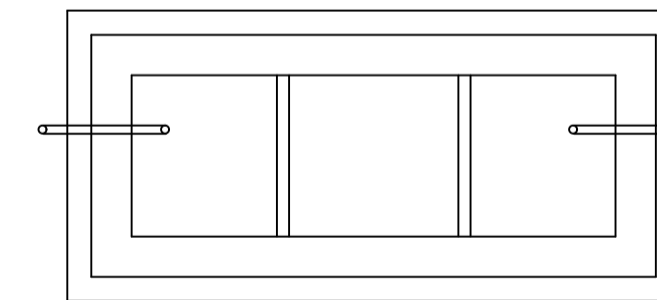

PLAN  
DETAIL OF SEPTIC TANK

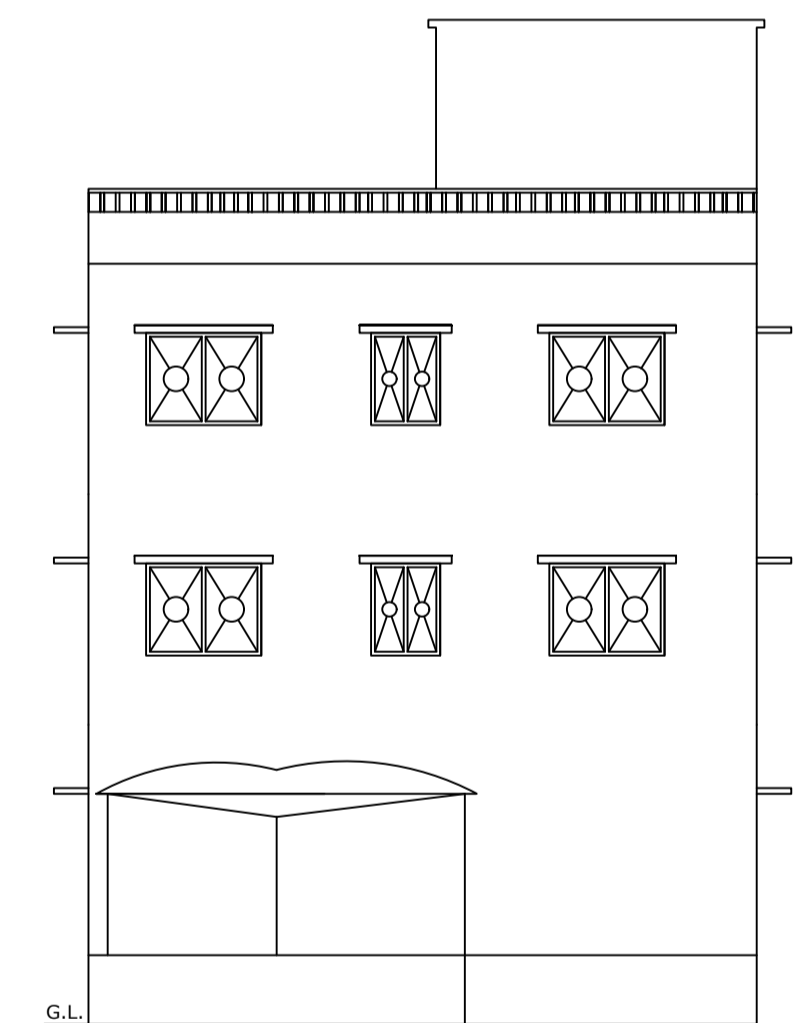

FRONT ELEVATION

Building :A (RAMESHWAR)

Floor Name	Total Built Up Area (Sq.mt.)	Deductions (Area in Sq.mt.)		Proposed FAR Area (Sq.mt.)	Total FAR Area (Sq.mt.)	Total Consumed Additional FAR Area (Sq.mt.)	Trmt (No.)
		Parking	Resi.				
Ground Floor	98.34	52.93	45.41	45.41	45.41	01	
First Floor	98.34	0.00	98.34	98.34	98.34	00	
Second Floor	98.34	0.00	98.34	98.34	98.34	00	
Terrace Floor	0.00	0.00	0.00	0.00	0.00	00	
Total :	295.02	52.93	242.09	242.09	242.09	01	
Total Number of Same Buildings	1						
Total :	295.02	52.93	242.09	242.09	242.09	01	

SCHEDULE OF DOOR:

BUILDING NAME	NAME	LENGTH	HEIGHT	NOS
A (RAMESHWAR)	D	0.90	2.10	23

SCHEDULE OF WINDOW/VENTILATION:

BUILDING NAME	NAME	LENGTH	HEIGHT	NOS
A (RAMESHWAR)	V	0.60	1.20	05
A (RAMESHWAR)	W	1.44	1.20	01
A (RAMESHWAR)	W	1.50	1.20	01
A (RAMESHWAR)	W	1.52	1.20	28

UnitBUA Table for Building :A (RAMESHWAR)

FLOOR	Name	UnitBUA Type	UnitBUA Area	Carpet Area	No. of Rooms	No. of Tenement
GROUND FLOOR PLAN	SPLIT A	FLAT	190.82	189.66	4	1
TYPICAL - 1 & 2 FLOOR PLAN	SPLIT A	FLAT	0.00	0.00	10	0
Total:	-	-	190.82	189.66	24	1

LTP NAME AND SIGNATURE	STRUCTURAL ENG'S NAME AND SIGNATURE	BUILDER NAME AND SIGNATURE	DIGITAL SIGNATURE
law chaturvedi LNP/ENG/0004/2018			