

**SITE PLAN**

**FAR & Tenement Details (Table 4c-1)**

Building	No. of Same Bldg	Total Built Up Area (Sq.mt.)	Proposed FAR Area (Sq.mt.) Resi.	Total FAR Area (Sq.mt.)	Total Consumed Additional FAR Area (Sq.mt.)	Tnmt (No.)
A (SATISH BHAGAT)	1	242.16	242.16	242.16	242.16	01
<b>Grand Total :</b>	<b>1</b>	<b>242.16</b>	<b>242.16</b>	<b>242.16</b>	<b>242.16</b>	<b>01</b>

Proposal Basis Information	
Proposal File No.	LNPC/BP/0048/W12/2023
Owner Name	satish kumar bhagat
Khata No	05
Plot No	487
Village Name	Amwatikar
Use	Residential
SubUse	Bungalow/ Dwelling / Non Apartment

AREA STATEMENT LATEHAR NAGAR PANCHAYAT		VERSION NO. : 1.0.66
PROJECT DETAIL		VERSION DATE: 16/10/2020
Region: JHARKHAND URBAN LOCAL BODIES	Plot Use: Residential	
District: LATEHAR	Plot SubUse: Bungalow/ Dwelling / Non Apartment	
Authority: LATEHAR NAGAR PANCHAYAT	PlotNearbyReligiousStructure: NA	
Inward No: LNPCI/BP/0048/W12/2023	Plot/SubPlot No: 487	
Application Type: General Proposal	North: Plot No. - NIZ VENDOR	
Project Type: Building Permission	South: Plot No. - NIZ VENDOR	
Nature of Development: New	East: Plot No. - NIZ VENDOR	
Location of Development Area: Old Area	West: Road Width - 3.66	
<b>AREA DETAILS:</b>		
AREA OF PLOT (Minimum)	(A)	SQ.MT. 301.01
NET AREA OF PLOT(Gross Plot Area - Deduction from Gross Plot area)	(A-Deductions)	301.01
Deduction for Balance Plot Area(from Gross Plot Area)		
Common Plot		23.33
Total		23.33
BALANCE AREA OF PLOT(Net Plot Area - Recreational/Amenity space)	(A-Deductions)	277.68
PLOT AREA FOR COVERAGE(Net Plot Area)	(A-Deductions)	301.01
Plot Area for FAR (Net Plot Area + Road Widening Area)	(A-Deductions)	301.01
<b>COVERAGE CHECK</b>		
Permissible Coverage area ( 60.00 % )		180.61
Proposed Coverage Area ( 40.23 % )		121.08
Total Prop. Coverage Area ( 40.23 % )		121.08
Balance coverage area ( 19.78 % )		59.53
<b>FAR CHECK</b>		
Perm. FAR Area ( 1.500 )		451.52
Total Perm. FAR area		451.52
Residential FAR		242.15
Proposed FAR Area		242.15
Total Proposed FAR Area		242.15
Consumed FAR (Factor)		0.80
Balance FAR Area		209.37
<b>BUILT UP AREA CHECK</b>		
Total Proposed BuiltUp Area		242.16
ARCHITECT (Regd)	law chaturvedi	
ENGINEER (Regd)		
SUPERVISOR (Regd)		
OWNER (Regd)	satish kumar bhagat	
DEVELOPMENT AUTHORITY		LOCAL BODY

COLOR INDEX	
PLOT BOUNDARY	
ABUTTING ROAD	
PROPOSED CONSTRUCTION	
COMMON PLOT	
ROAD WIDENING AREA	
EXISTING (To be retained)	
EXISTING (To be demolished)	

**Buildingwise Floor FAR Details**

Floor Name	Building Name		Total	
	Proposed Built Up Area (Sq.mt.)	Proposed FAR Area (Sq.mt.)	Total Proposed Built Up Area (Sq.mt.)	Total FAR Area (Sq.mt.)
Ground Floor	121.08	121.08	121.08	121.08
First Floor	121.08	121.08	121.08	121.08
Terrace Floor	0.00	0.00	0.00	0.00
<b>Total :</b>	<b>242.16</b>	<b>242.16</b>	<b>242.16</b>	<b>242.16</b>

**Building USE/SUBUSE Details**

Building Name	Building Use	Building SubUse	Building Structure
A (SATISH BHAGAT)	Residential	Bungalow/ Dwelling / Non Apartment	Non-Highrise

LTP NAME AND SIGNATURE	STRUCTURAL ENG'S NAME AND SIGNATURE	BUILDER NAME AND SIGNATURE	DIGITAL SIGNATURE
law chaturvedi LNPC/ENG/0004/2018			

Proposal Basis Information	
Proposal File No.	LNPC/BP/0048/W12/2023
Owner Name	Satish Kumar Bhagat
Khata No.	05
Plot No.	487
Village Name	Amwatikar
Use	Residential
SubUse	Bungalow/ Dwelling / Non Apartment

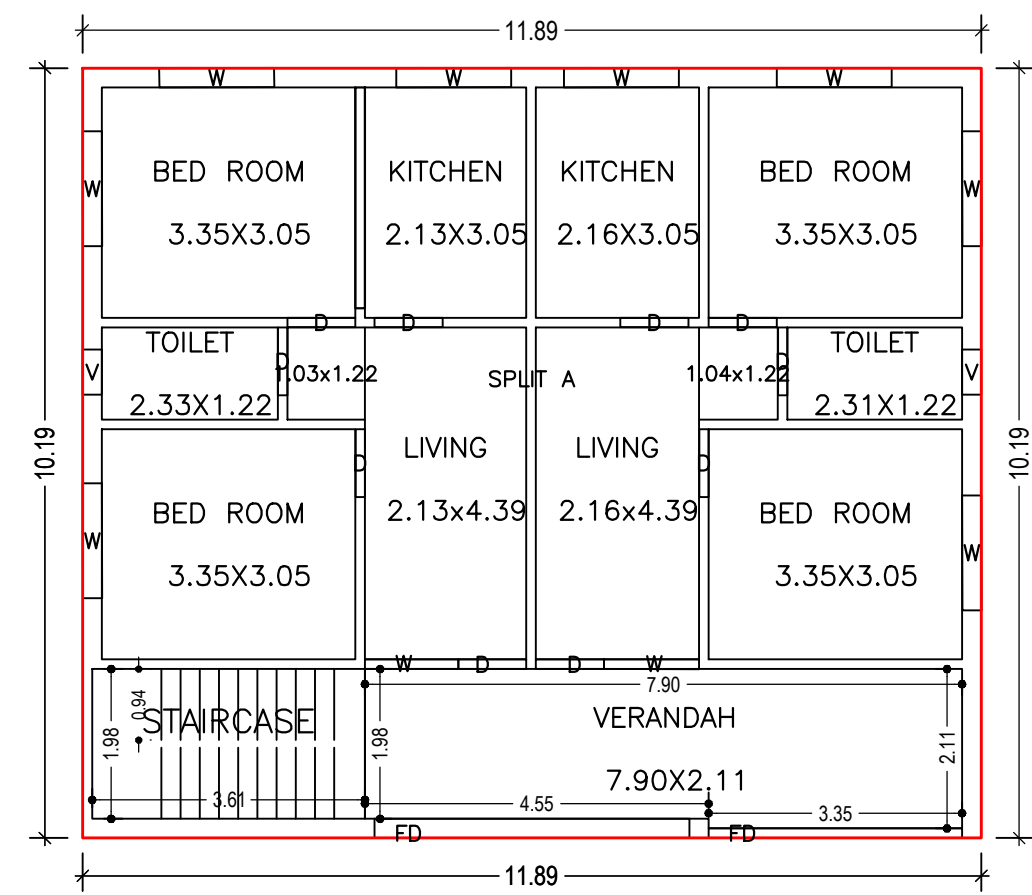

GROUND FLOOR PLAN (Proposed) (SCALE 1:100)

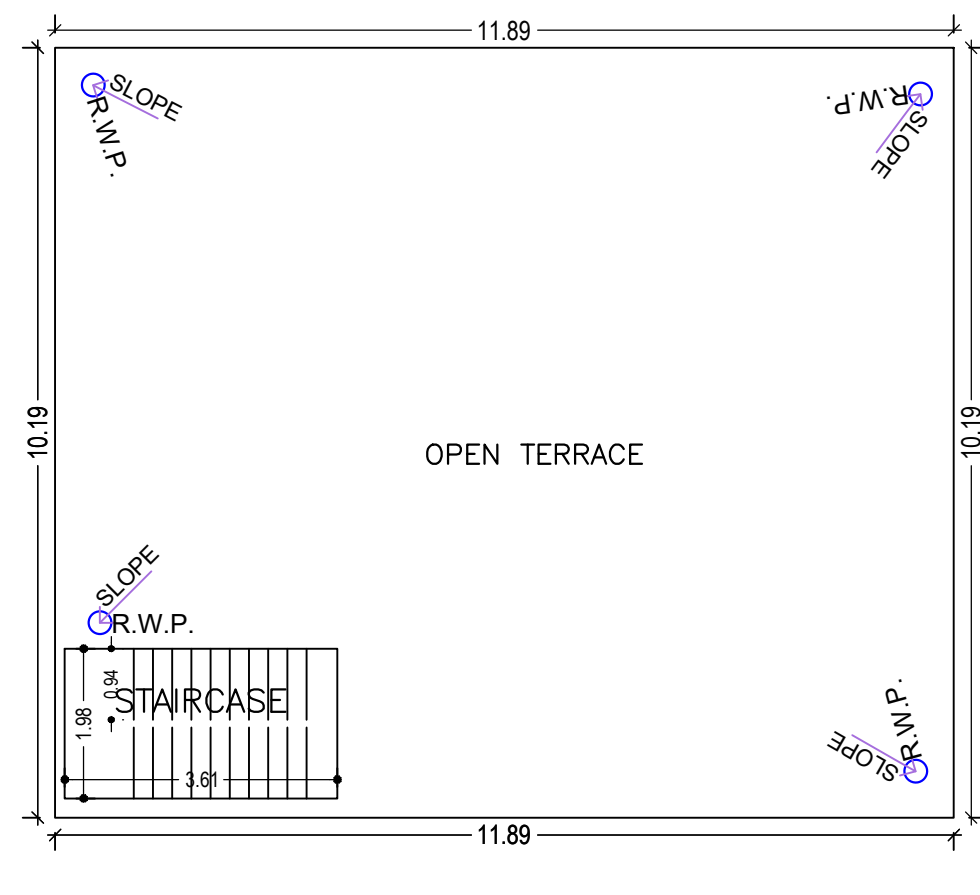

TERRACE FLOOR PLAN (SCALE 1:100)

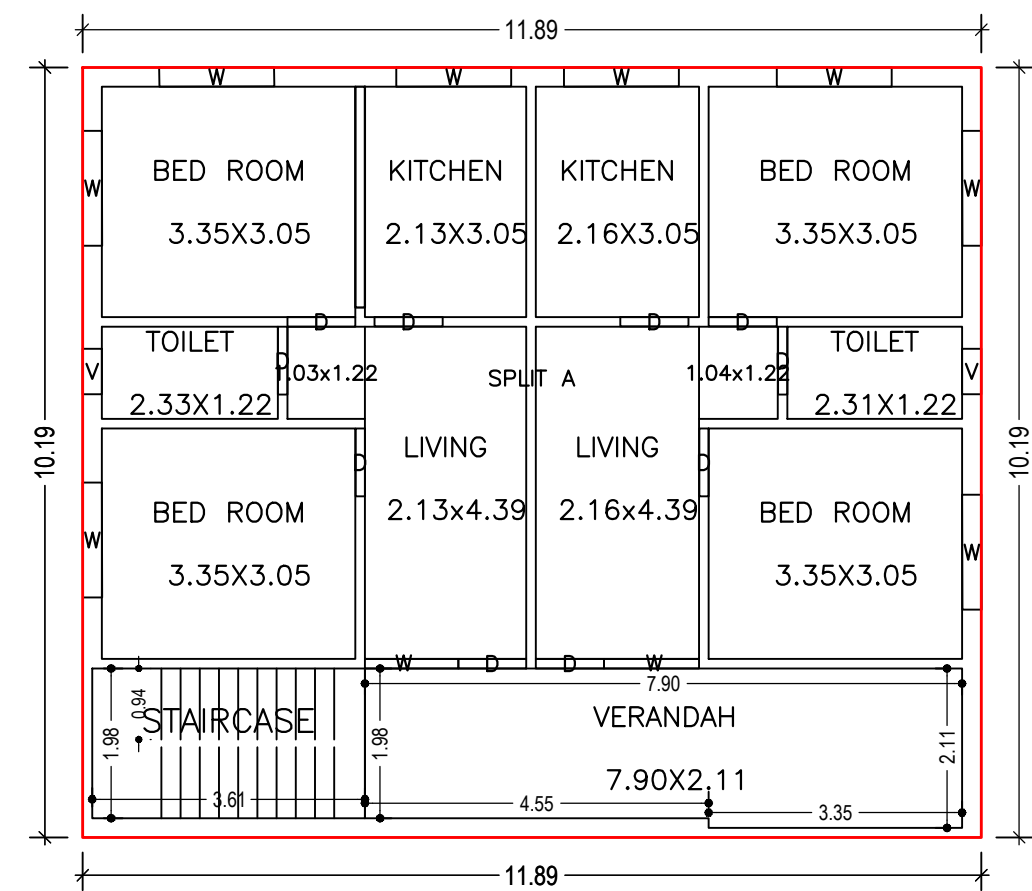

FIRST FLOOR PLAN (Proposed) (SCALE 1:100)

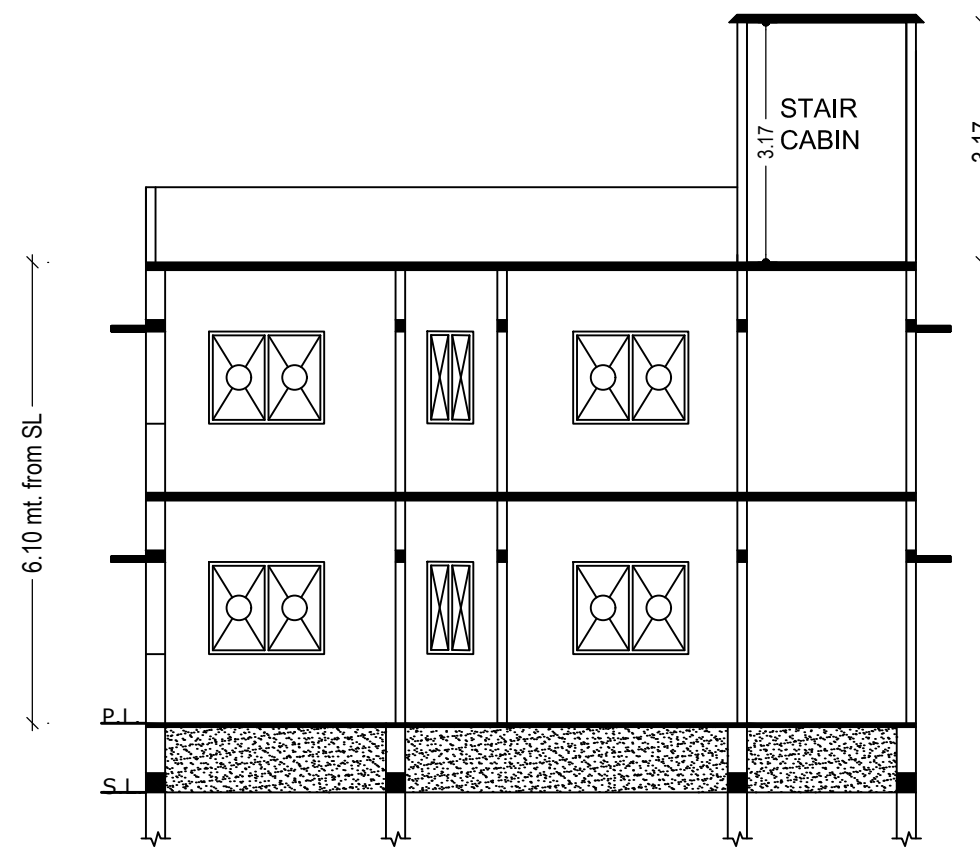

SECTION- XX

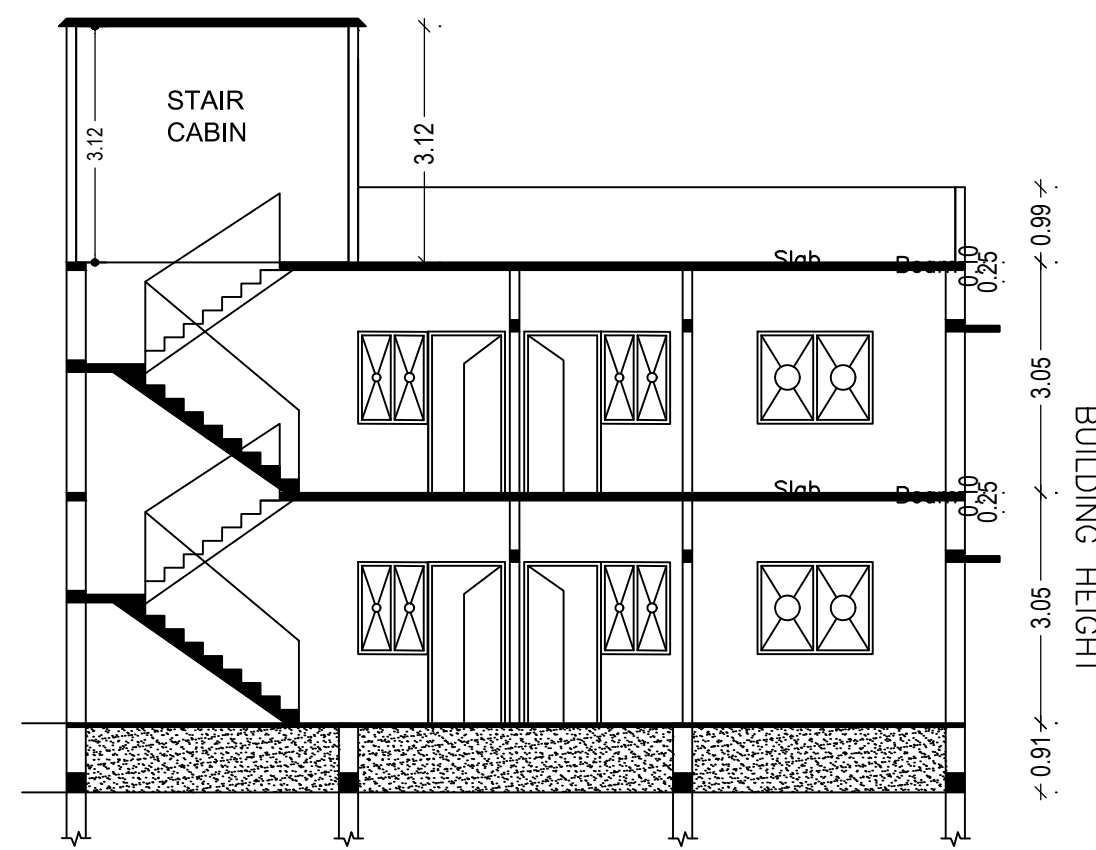

SECTION- YY

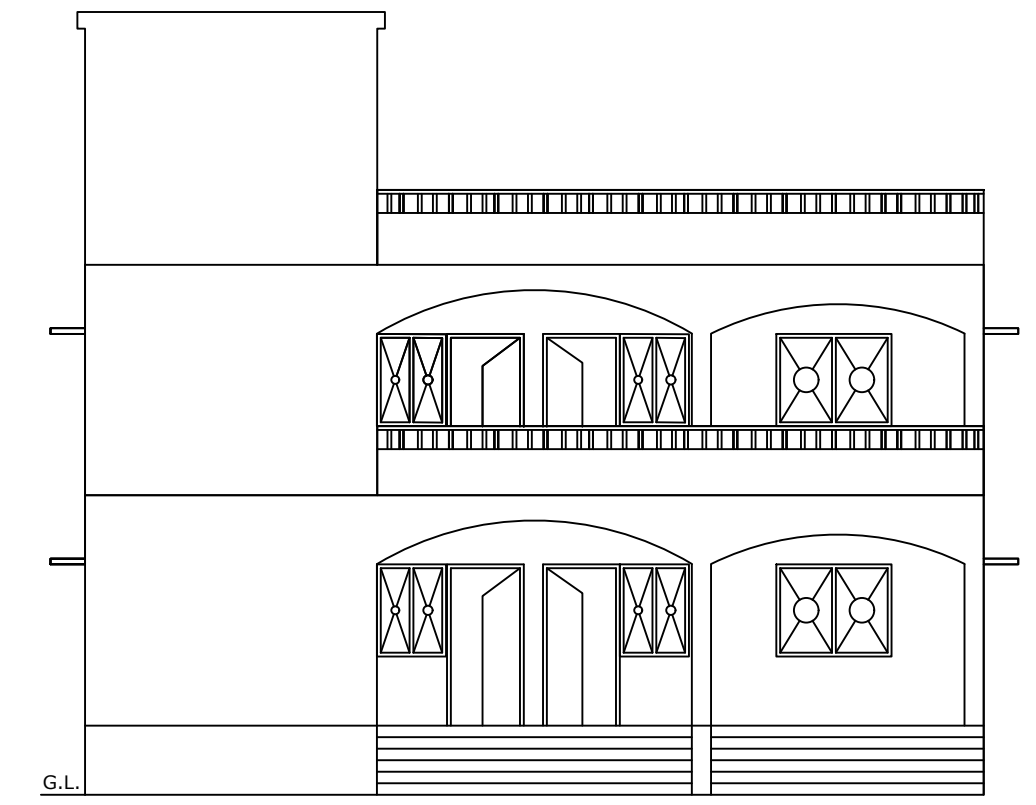
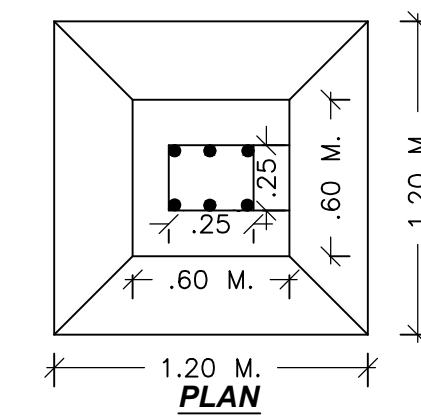
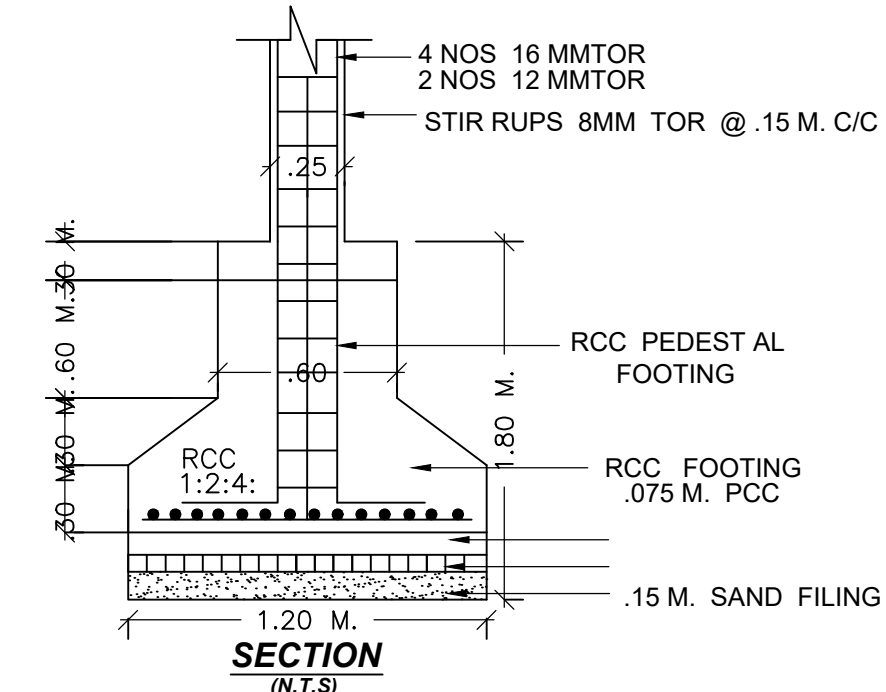

FRONT ELEVATION

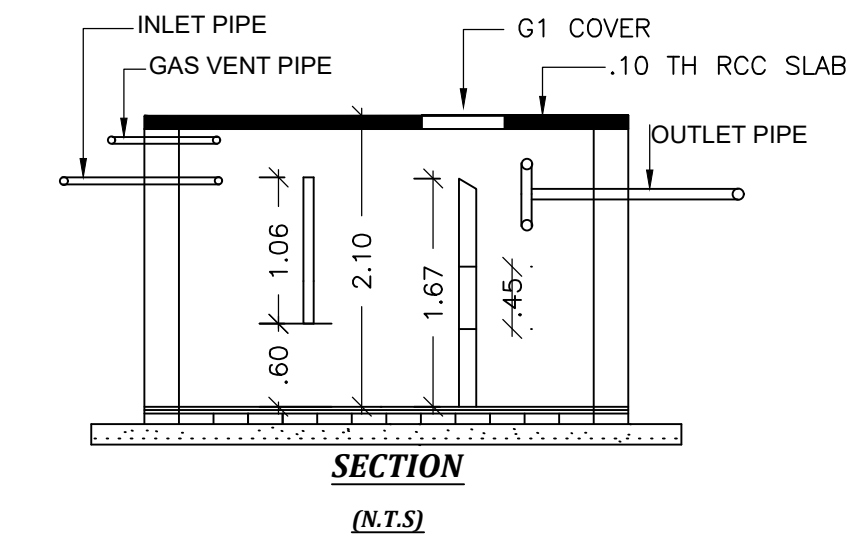

SECTION (N.T.S)

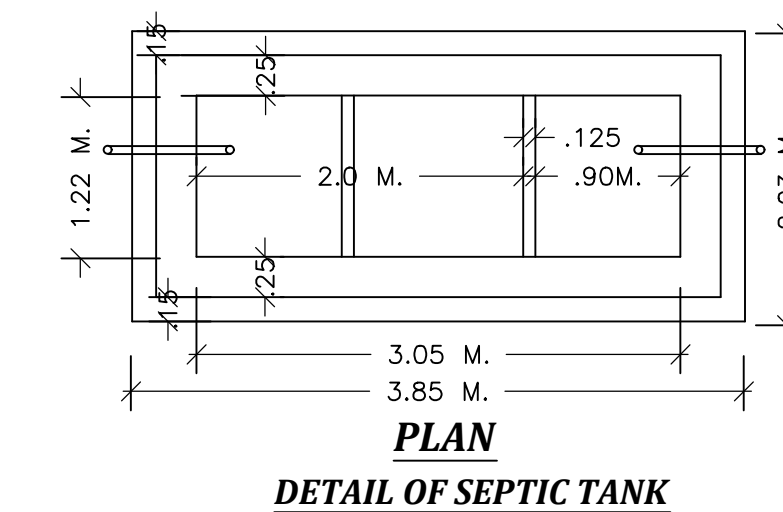

PLAN (N.T.S) DETAIL OF SEPTIC TANK

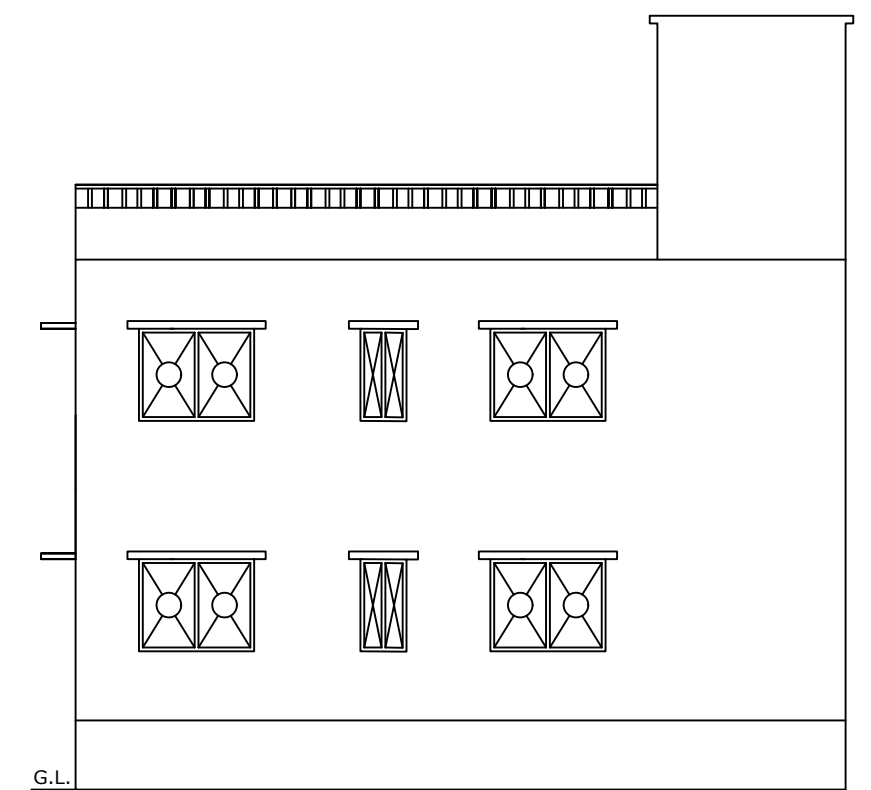

SOUTH SIDE ELEVATION

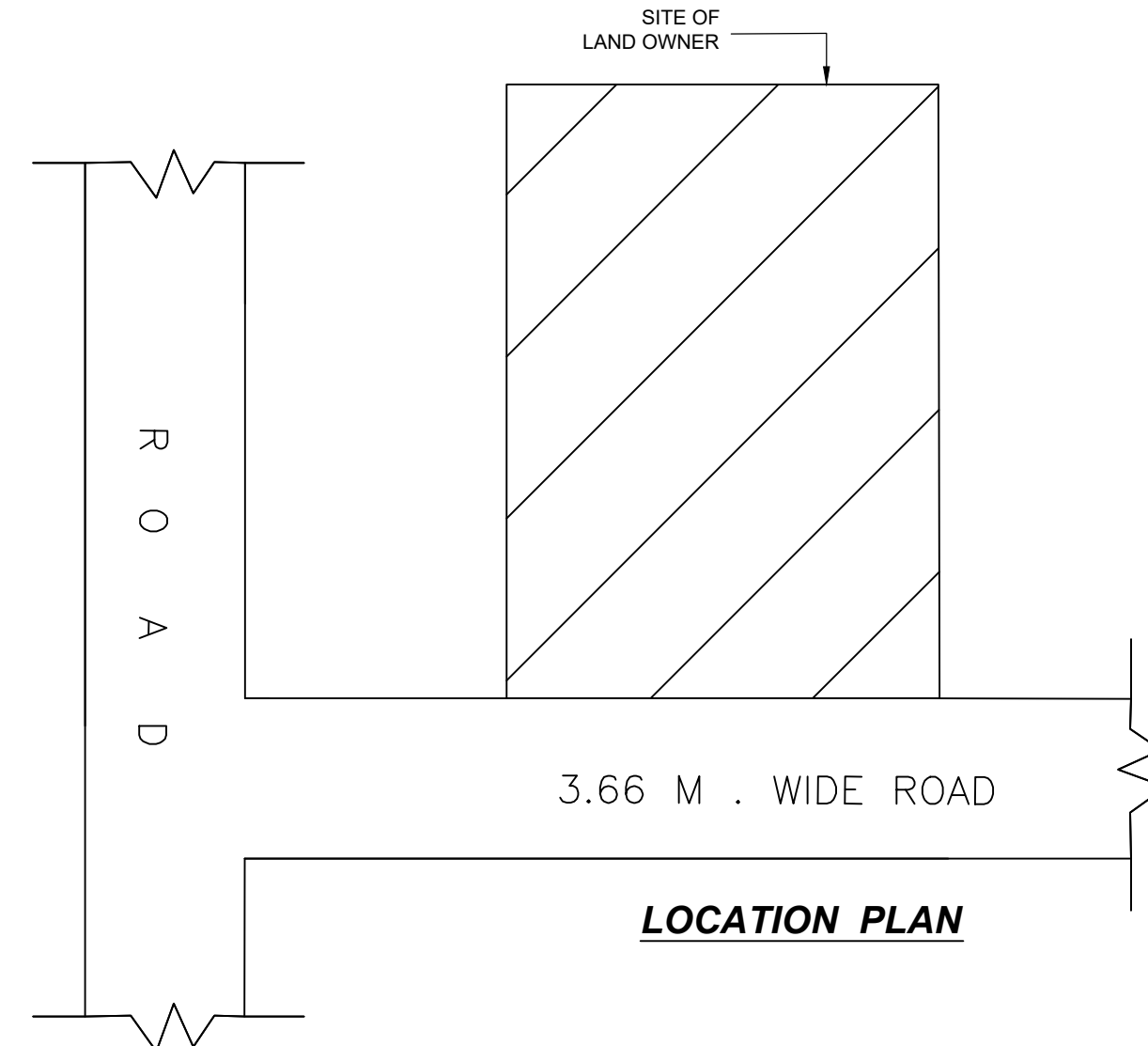

LOCATION PLAN

Building :A (SATISH BHAGAT)

Floor Name	Total Built Up Area (Sq.mt.)	Proposed FAR Area (Sq.mt.) Resi.	Total FAR Area (Sq.mt.)	Total Consumed Additional FAR Area (Sq.mt.)	Tnmt (No.)
Ground Floor	121.08	121.08	121.08	121.08	01
First Floor	121.08	121.08	121.08	121.08	00
Terrace Floor	0.00	0.00	0.00	0.00	00
Total:	242.16	242.16	242.16	242.16	01
Total Number of Same Buildings	1				
Total:	242.16	242.16	242.16	242.16	01

SCHEDULE OF DOOR:

BUILDING NAME	NAME	LENGTH	HEIGHT	NOS
A (SATISH BHAGAT)	D	0.90	2.10	20
A (SATISH BHAGAT)	FD	3.35	2.10	01
A (SATISH BHAGAT)	FD	4.17	2.10	01

SCHEDULE OF WINDOW/VENTILATION:

BUILDING NAME	NAME	LENGTH	HEIGHT	NOS
A (SATISH BHAGAT)	V	0.60	0.60	04
A (SATISH BHAGAT)	W	1.23	1.20	02
A (SATISH BHAGAT)	W	1.26	1.20	02
A (SATISH BHAGAT)	W	1.52	1.20	16

UnitBUA Table for Building :A (SATISH BHAGAT)

FLOOR	Name	UnitBUA Type	UnitBUA Area	Carpet Area	No. of Rooms	No. of Tenement
GROUND FLOOR PLAN	SPLIT A	FLAT	206.42	205.68	11	1
FIRST FLOOR PLAN	SPLIT A	FLAT	0.00	0.00	11	0
Total:	-	-	206.42	205.68	22	1

LTP NAME AND SIGNATURE	STRUCTURAL ENG'S NAME AND SIGNATURE	BUILDER NAME AND SIGNATURE	DIGITAL SIGNATURE
law chaturvedi LNPC/ENG/0004/2018			