

FRONT ELEVATION

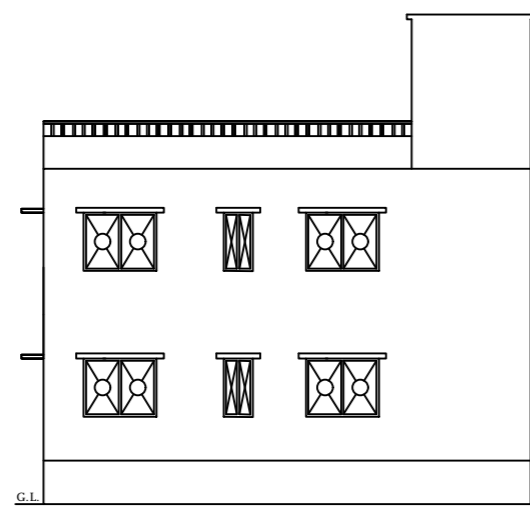

SOUTH SIDE ELEVATION

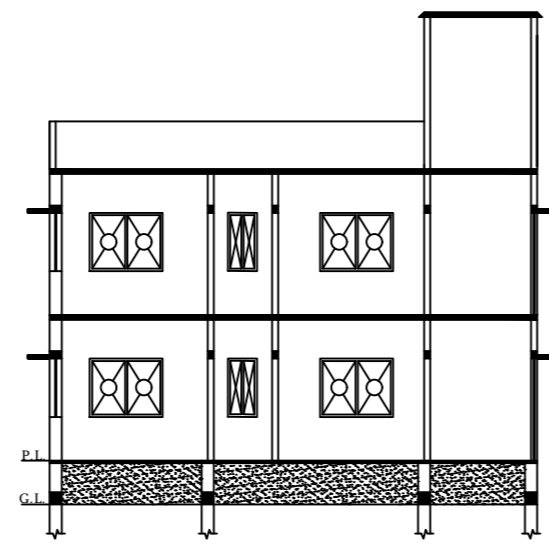

SECTION- XX

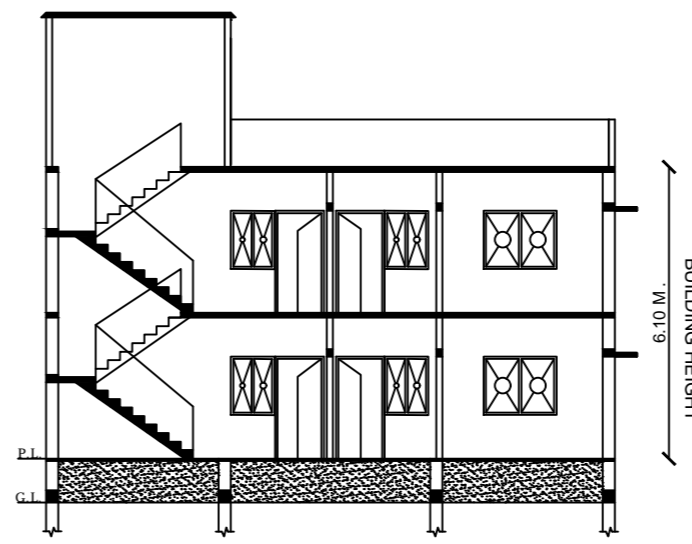

SECTION- YY

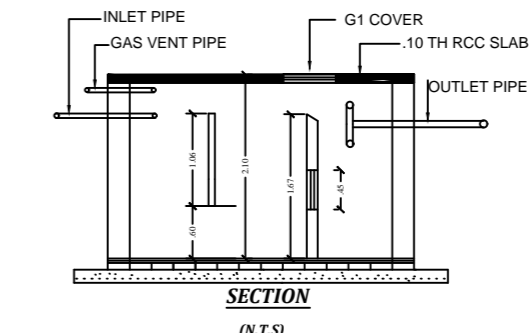

SECTION (N.T.S)

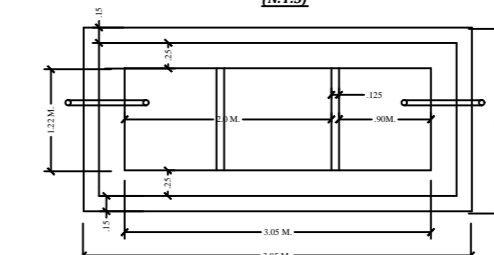

PLAN  
DETAIL OF SEPTIC TANK

SCHEDULE OF DS & WS

TYPE	SIZE	REMARKS
D	1.06 M.X2.10 M.	F PANELED
D1	0.06 M.X2.10 M.	F PANELED
D2	0.75 M.X2.10 M.	F PANELED
W	1.50 M.X1.20 M.	F GLAZZED
W1	1.20 M.X1.20 M.	F GLAZZED
W2	0.91 M.X1.20 M.	F GLAZZED
C.GATE	2.10 M.X2.10 M.	IRON

SPECIFICATION

- DETAIL OF R.C.C. FOOTING COLUMN FON ( M.25 )
- 1ST CLASS BRICK WORK IN CEMENT PLASTER ( 1:6 )
- 1.25X.15TH. R.C.C. LINTEL BAND OVER DOOR'S & WINDOW'S
- .10TH. LIME CON. TERR.OVER .10TH. R.C.C. ROOF SLAB(M.25)
- SAL WOOD FRAME & SUAM WOOD SHUTTER.
- 0.012TH. IN CEMENT PLASTER IN BOTH SIDE WACC ( 1:6 )
- MARBLE OR MOSAIC FLOORING OVER .110TH. DRY RAMMED KHOA OVER B.F. SOILING , OVER LOCAL SAND FILLING .
- 2 CUAT OF WHITE & COLOUR WASH AS PER CHOICE.
- 17CM.WIDE & 30 CM. PUCCA DRAIN AROUND THE BUILDING .

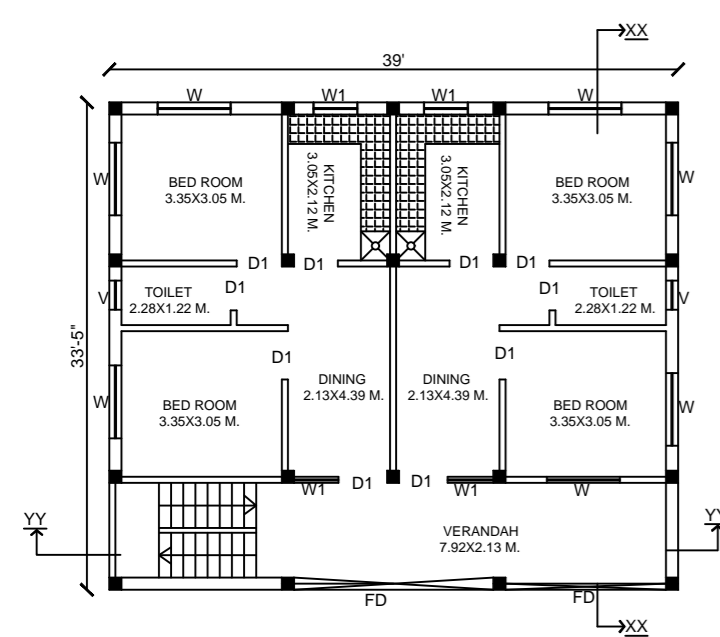

PROPOSED GROUND FLOOR PLAN

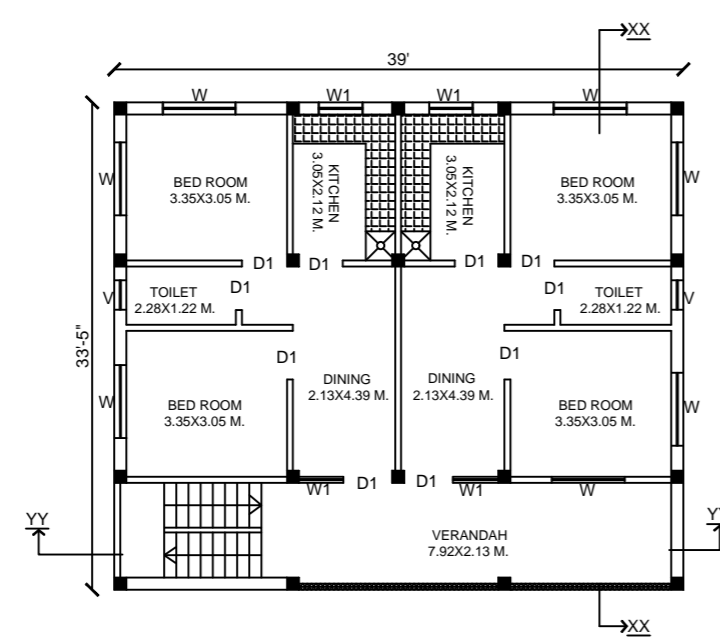

PROPOSED FIRST FLOOR PLAN

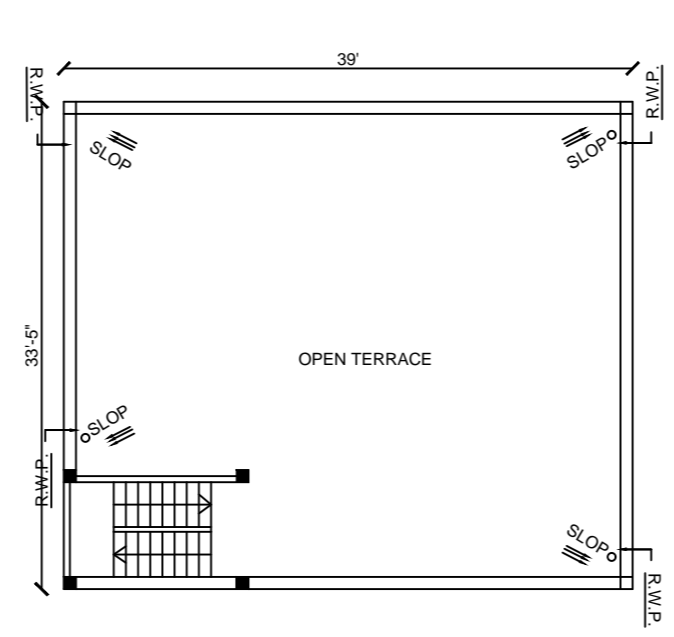

TERRACE FLOOR PLAN

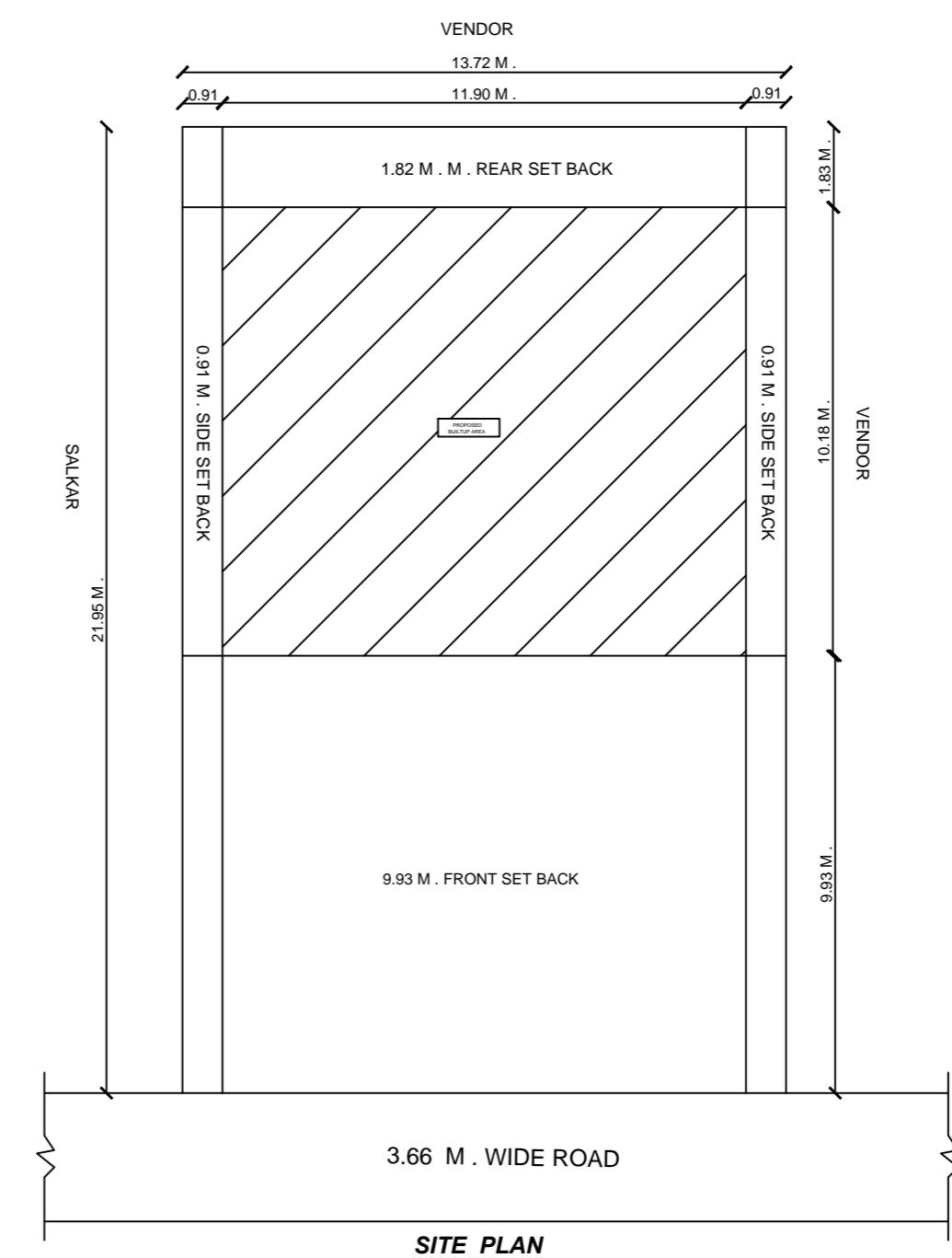

SITE PLAN

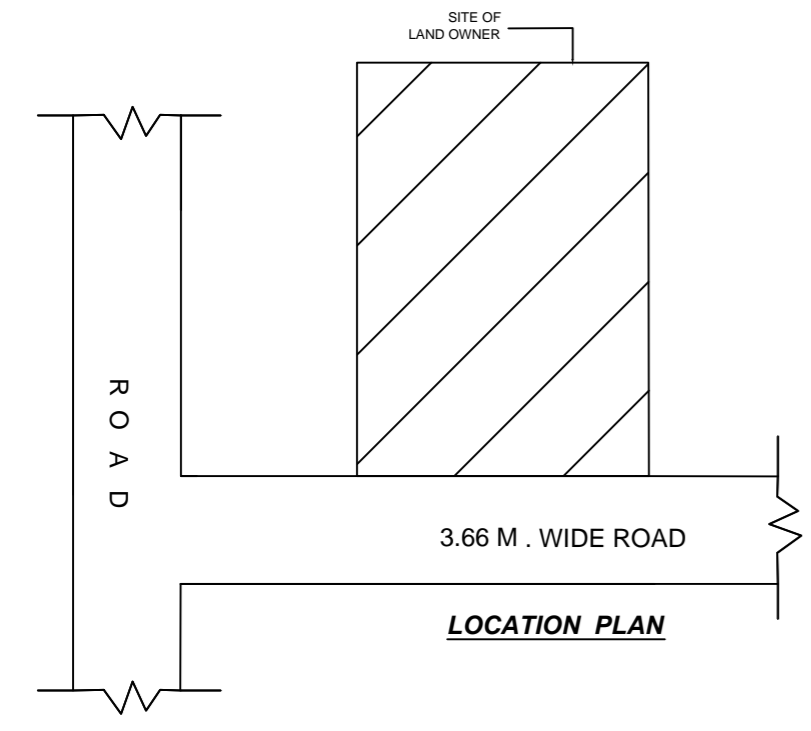

LOCATION PLAN

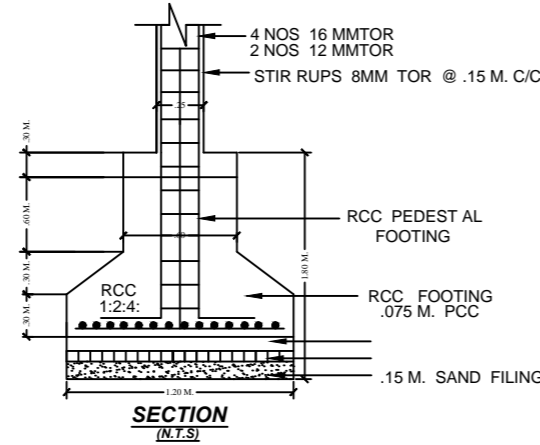

SECTION (M.T.S)

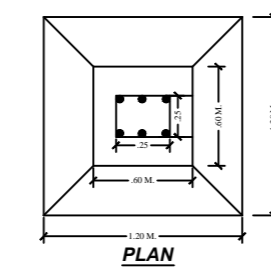

PLAN

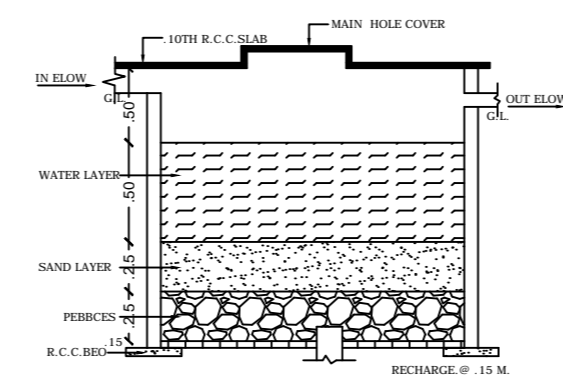

DETAIL OF RAIN WATER HARVESTING AND RECHARGE PIT.(N.T.S.)

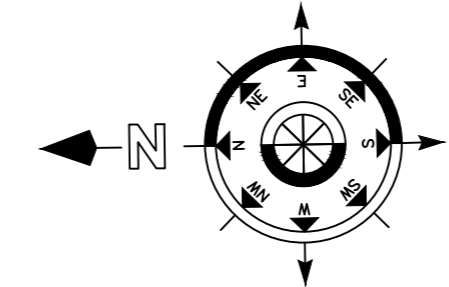

TOTAL PLOT AREA	=	301.15	SQM.
NET PLOT AREA	=	301.15	SQM.
TOTAL OPEN LAND AREA	=	180.01	SQM.
GROUND FLOOR B/A	=	121.14	SQM.
FIRST FLOOR B/A	=	121.14	SQM.
TOTAL B/A	=	242.28	SQM.
F.A.R.	=	0.80	
% OF COVRED AREA	=	40 %	
BUILDING HEIGHT	=	6.10 M.	

PROPOSED RESIDENTIAL BUILDING OF  
 NAME- SRI SATISH KUMAR BHAGAT  
 S/O. - SRI HARI BHAGAT  
 MAUZA- AMBATIKAR  
 P.S. - LATEHAR  
 P.S. NO.- 255  
 WARD NO.- 0  
 KHATA NO.- 05  
 PLOT NO.- 487  
 HOLDING NO.-  
 TOUZI NO.- 51  
 DIST - LATEHAR (JHARKHAND)

MAP APPROVED BY

SIGNATURE OF APPLICANT

SIGNATURE OF ENGINEER