

GROUND FLOOR PLAN (Proposed) (SCALE 1:100)

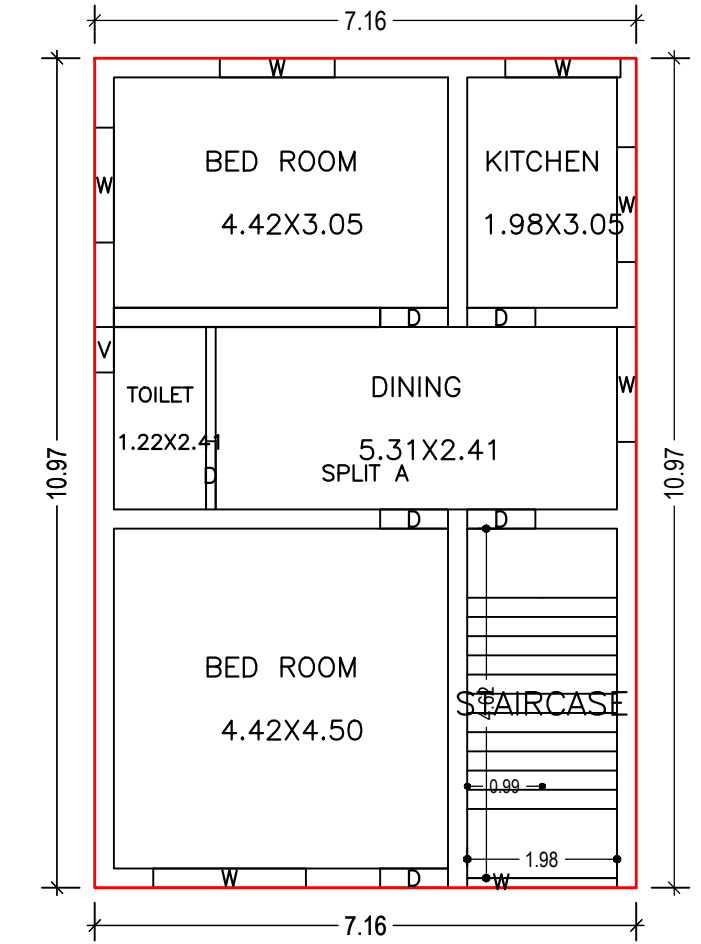

FIRST FLOOR PLAN (Proposed) (SCALE 1:100)

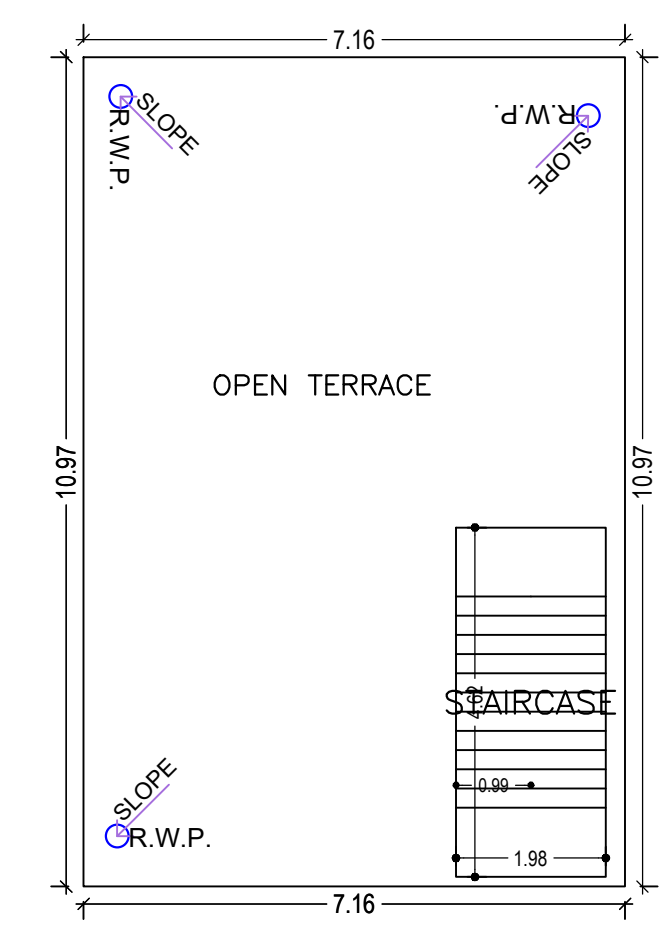

TERRACE FLOOR PLAN (SCALE 1:100)

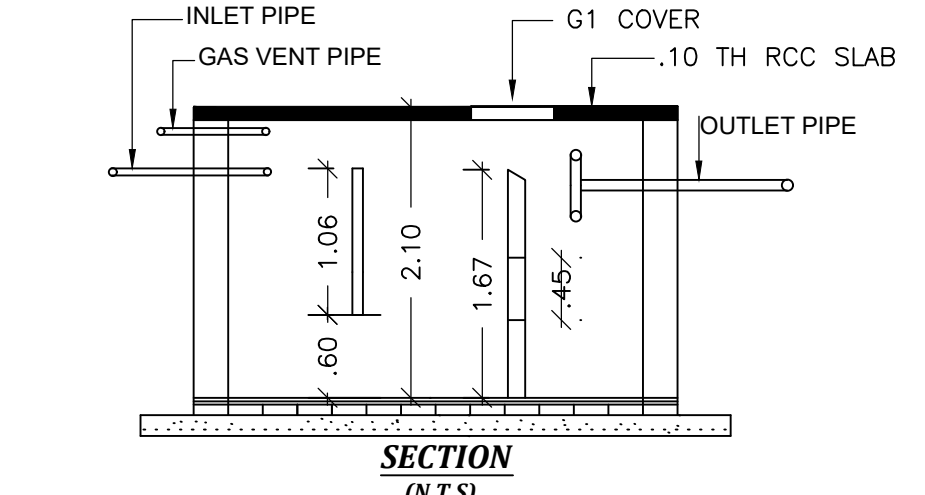

SECTION (N.T.S)

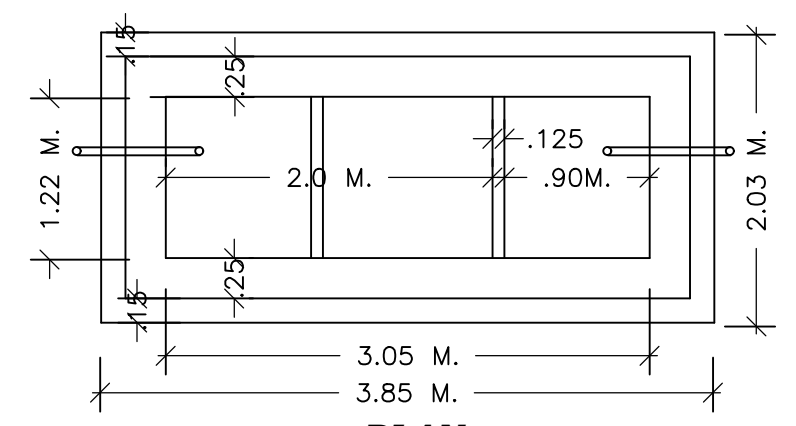

PLAN (N.T.S) DETAIL OF SEPTIC TANK

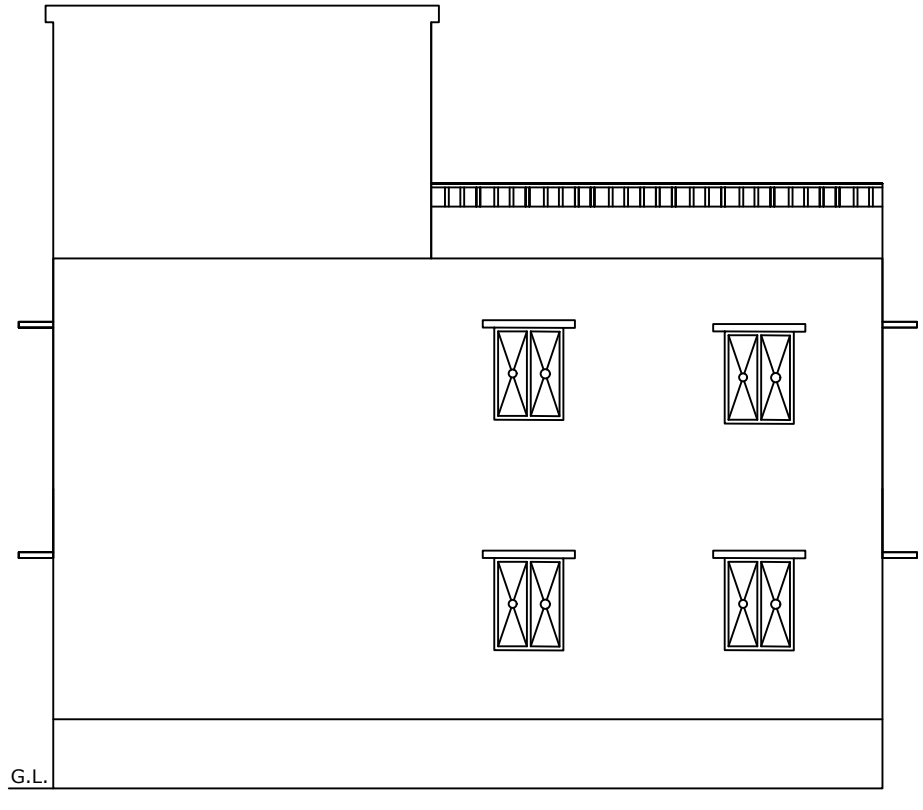

EAST SIDE ELEVATION

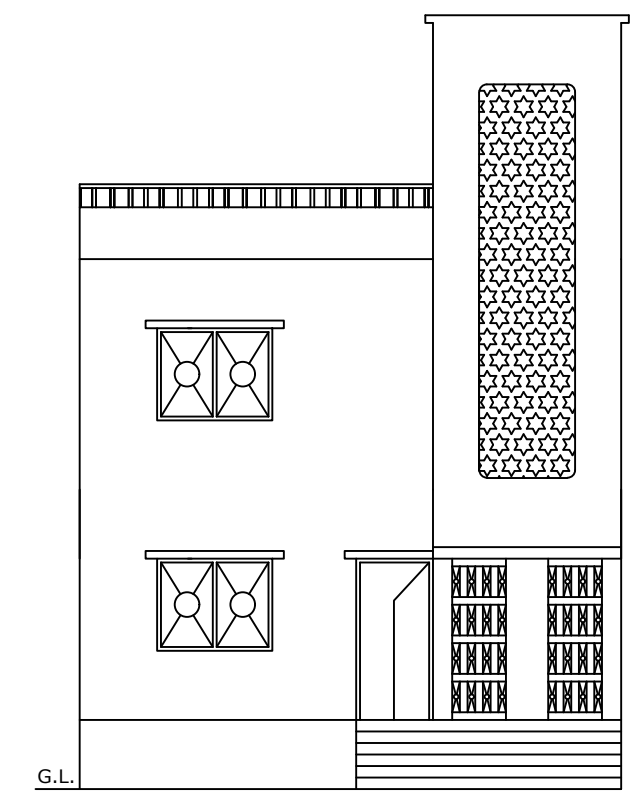

FRONT ELEVATION

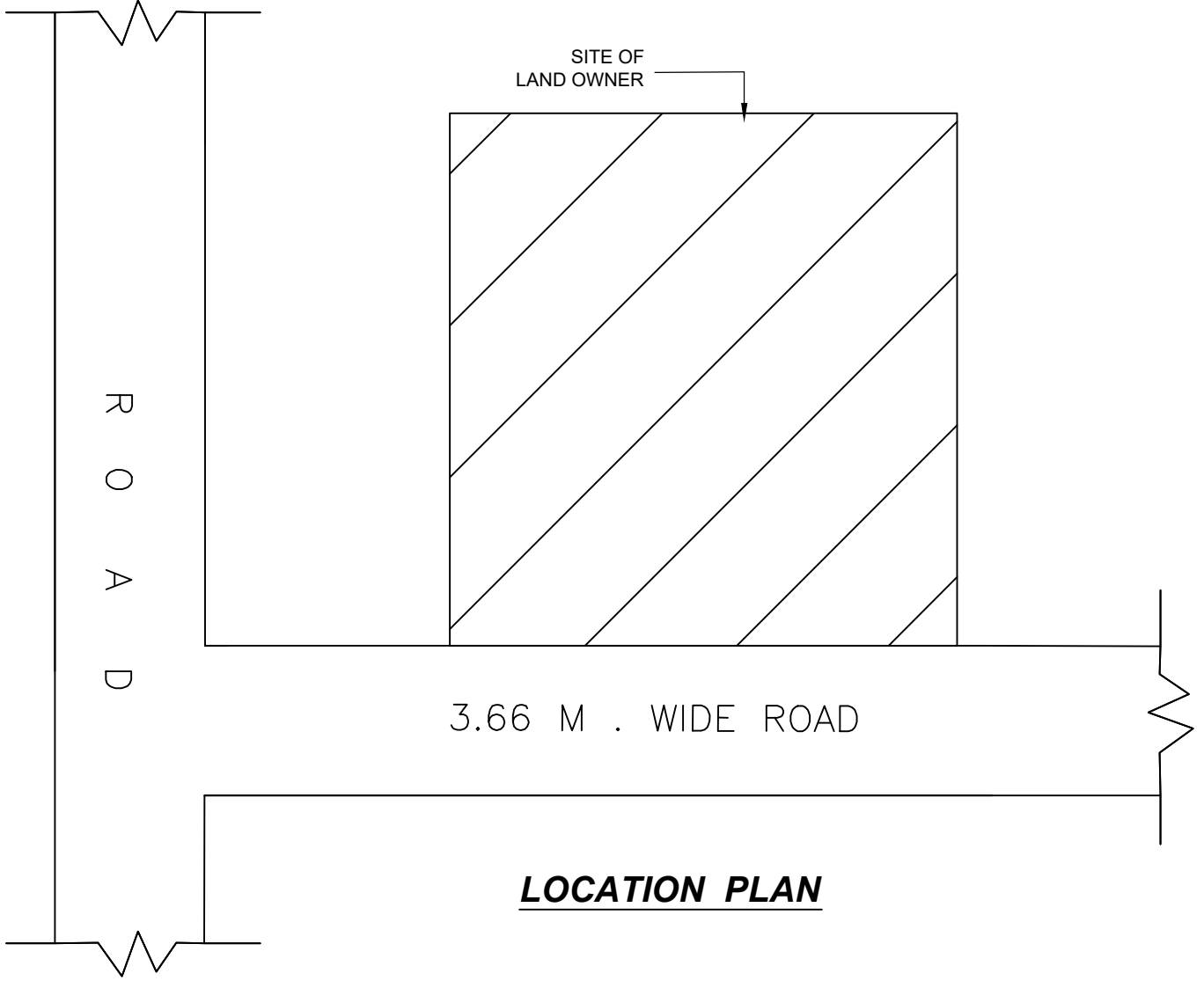

LOCATION PLAN

Proposal Basic Information

Proposal File No.	LNPC/BP/0050/W05/2023
Owner Name	POONAM KUMARI
Khata No	84
Plot No	116
Village Name	Latehar
Use	Residential
SubUse	Bungalow/ Dwelling / Non Apartment

AREA STATEMENT LATEHAR NAGAR PANCHAYAT	VERSION NO.: 1.0.66	SQ.MT.
PROJECT DETAIL:	VERSION DATE: 16/10/2020	
Region: JHARKHAND URBAN LOCAL BODIES	Plot Use: Residential	
District: LATEHAR	Plot SubUse: Bungalow/ Dwelling / Non Apartment	
Authority: LATEHAR NAGAR PANCHAYAT	PlotNearbyReligiousStructure: NA	
Inward_No: LNPC/BP/0050/W05/2023	Plot/SubPlot No: 116	
Application Type: General Proposal	North: Plot No - NARESH THAKUR	
Project Type: Building Permission	South: Road Width - 3.66	
Nature of Development: New	East: Plot No. - RAJ KUMAR PRASAD SONI	
Location of Development Area: Old Area	West: Plot No. - UMAKANT YEDAV	
AREA DETAILS:		
AREA OF PLOT (Minimum)	(A)	121.21
NET AREA OF PLOT(Gross Plot Area - Deduction from Gross Plot area)	(A-Deductions)	121.21
Deduction for Balance Plot Area(from Gross Plot Area)		
Common Plot		11.95
Total		11.95
BALANCE AREA OF PLOT(Net Plot Area - Recreational/Amenity space)	(A-Deductions)	109.26
PLOT AREA FOR COVERAGE(Net Plot Area)	(A-Deductions)	121.21
Plot Area for FAR (Net Plot Area + Road/Widening Area)	(A-Deductions)	121.21
COVERAGE CHECK:		
Permissible Coverage area (70.00 %)		84.85
Proposed Coverage Area (64.85 %)		78.60
Total Prop. Coverage Area (64.85 %)		78.60
Balance coverage area (5.16 %)		6.25
FAR CHECK:		
Perm. FAR Area (1.500)		181.82
Total Perm. FAR area		181.82
Residential FAR:		157.19
Proposed FAR Area		157.19
Total Proposed FAR Area		157.19
Consumed FAR (Factor)		1.30
Balance FAR Area		24.63
BUILT UP AREA CHECK:		
Total Proposed BuiltUp Area		157.20
ARCHITECT (Regd)	law chaturvedi	
ENGINEER (Regd)		
SUPERVISOR (Regd)		
OWNER (Regd)	POONAM KUMARI	
DEVELOPMENT AUTHORITY	LOCAL BODY	

Building :A (POONAM)

Floor Name	Total Built Up Area (Sq.mt.)	Proposed FAR Area (Sq.mt.) Resi.	Total FAR Area (Sq.mt.)	Total Consumed Additional FAR Area (Sq.mt.)	Trmt (No.)
Ground Floor	78.60	78.60	78.60	78.60	01
First Floor	78.60	78.60	78.60	78.60	00
Terrace Floor	0.00	0.00	0.00	0.00	00
Total :	157.20	157.20	157.20	157.20	01
Total Number of Same Buildings	1				
Total :	157.20	157.20	157.20	157.20	01

SCHEDULE OF DOOR:

BUILDING NAME	NAME	LENGTH	HEIGHT	NOS
A (POONAM)	D	0.90	2.10	12

SCHEDULE OF WINDOW/VENTILATION:

BUILDING NAME	NAME	LENGTH	HEIGHT	NOS
A (POONAM)	V	0.60	0.60	02
A (POONAM)	W	1.52	1.20	10
A (POONAM)	W	2.02	1.20	02

Building USE/SUBUSE Details

Building Name	Building Use	Building SubUse	Building Structure
A (POONAM)	Residential	Bungalow/ Dwelling / Non Apartment	Non-Highrise

UnitBUA Table for Building :A (POONAM)

FLOOR	Name	UnitBUA Type	UnitBUA Area	Carpet Area	No. of Rooms	No. of Tenement
GROUND FLOOR PLAN	SPLIT A	FLAT	118.05	116.26	5	1
FIRST FLOOR PLAN	SPLIT A	FLAT	0.00	0.00	5	0
Total:	-	-	118.05	116.26	10	1

Buildingwise Floor FAR Details

Floor Name	Building Name A (POONAM)		Total	
	Proposed Built Up Area (Sq.mt.)	Proposed FAR Area (Sq.mt.)	Total Proposed Built Up Area (Sq.mt.)	Total FAR Area (Sq.mt.)
Ground Floor	78.60	78.60	78.60	78.60
First Floor	78.60	78.60	78.60	78.60
Terrace Floor	0.00	0.00	0.00	0.00
Total :	157.20	157.20	157.20	157.20

FAR & Tenement Details (Table 4c-1)

Building	No. of Same Bldg	Total Built Up Area (Sq.mt.)	Proposed FAR Area (Sq.mt.) Resi.	Total FAR Area (Sq.mt.)	Total Consumed Additional FAR Area (Sq.mt.)	Trmt (No.)
A (POONAM)	1	157.20	157.20	157.20	157.20	01
Grand Total :	1	157.20	157.20	157.20	157.20	01

COLOR INDEX

PLOT BOUNDARY	Black
ABUTTING ROAD	Green
PROPOSED CONSTRUCTION	Red
COMMON PLOT	Yellow
ROAD WIDENING AREA	Blue
EXISTING (To be retained)	Light Blue
EXISTING (To be demolished)	Light Yellow

LTP NAME AND SIGNATURE	STRUCTURAL ENG'S NAME AND SIGNATURE	BUILDER NAME AND SIGNATURE	DIGITAL SIGNATURE
law chaturvedi LNPC/ENG/0004/2018			