

FRONT ELEVATION

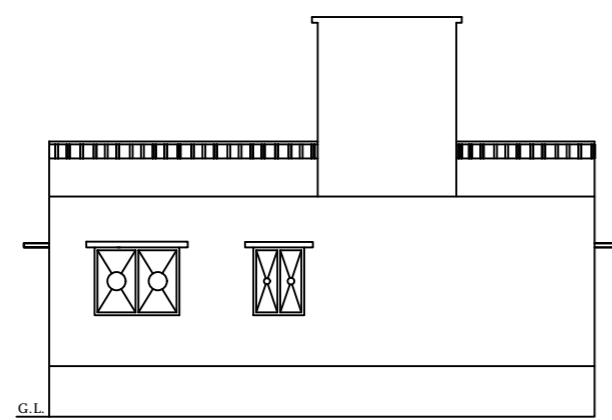

SOUTH SIDE ELEVATION

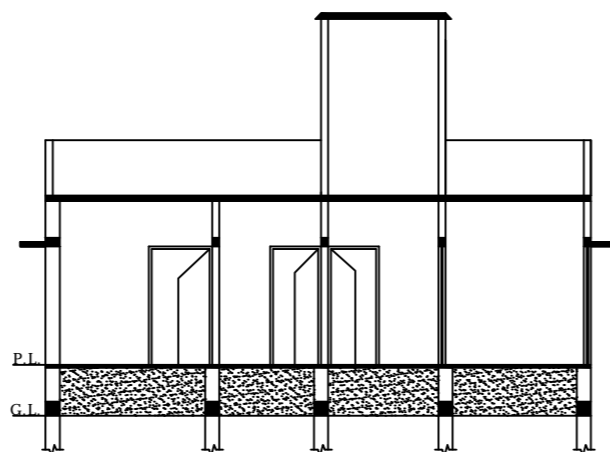

SECTION- XX

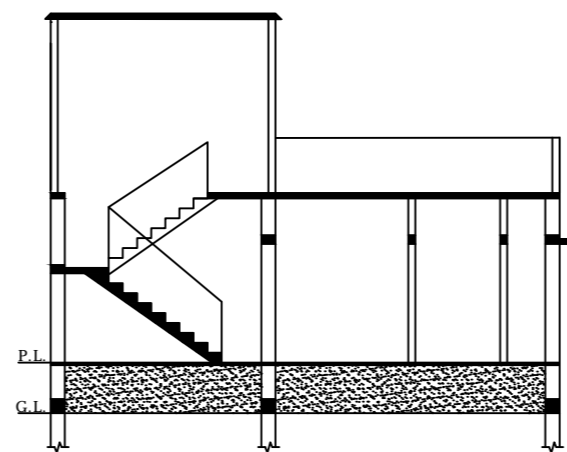

SECTION- YY

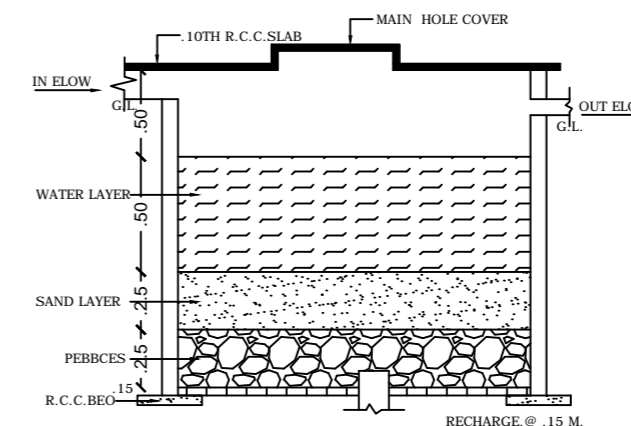

DETAIL OF RAIN WATER HARVESTING AND RECHARGE PIT. (N.T.S.)

SCHEDULE OF DS & WS

TYPE	SIZE	REMARKS
D	1.06 M.X2.10 M.	F PANELED
D1	0.06 M.X2.10 M.	F PANELED
D2	0.75 M.X2.10 M.	F PANELED
W	1.50 M.X1.20 M.	F GLAZED
W1	1.20 M.X1.20 M.	F GLAZED
W2	0.91 M.X1.20 M.	F GLAZED
C.GATE	2.10 M.X2.10 M.	IRON

SPECIFICATION

1. DETAIL OF R.C.C. FOOTING COLUMN FON (M.25)
2. 1ST CLASS BRICK WORK IN CEMENT PLASTER (1:6)
3. 1.25X.15TH. R.C.C. LINTEL BAND OVER DOOR'S & WINDOW'S
4. 10TH. LIME CON. TERR.OVER .10TH. R.C.C. ROOF SLAB(M.25)
5. SAL WOOD FRAME & SUAM WOOD SHUTTER.
6. 0.012TH. IN CEMENT PLASTER IN BOTH SIDE WACC (1:6)
7. MARBLE OR MOSAIC FLOORING OVER .110TH. DRY RAMMED KHOA OVER B.F. SOILING , OVER LOCAL SAND FILLING .
8. 2 CUAT OF WHITE & COLOUR WASH AS PER CHOICE.
9. 17CM.WIDE & 30 CM. PUCCA DRAIN AROUND THE BUILDING .

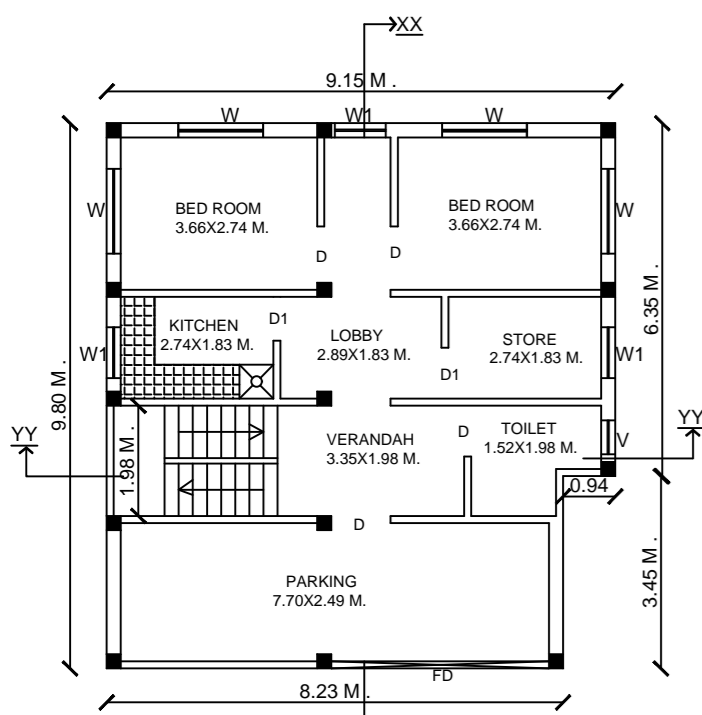

PROPOSED GROUND FLOOR PLAN

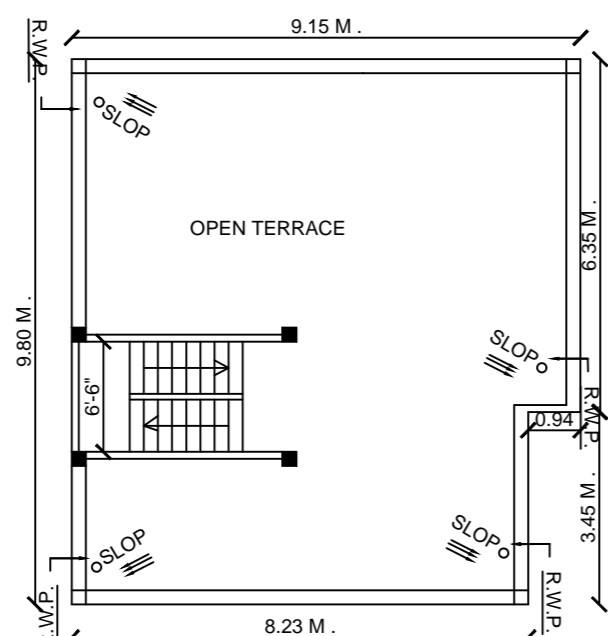

TERRACE FLOOR PLAN

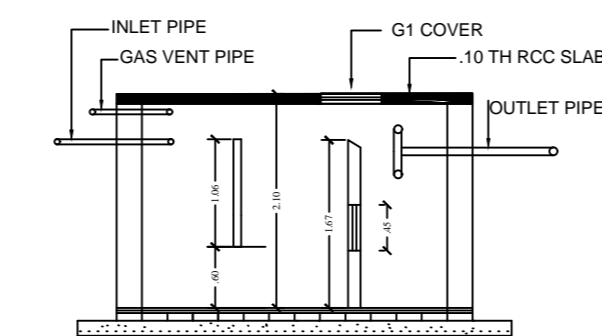

SECTION (N.T.S.)

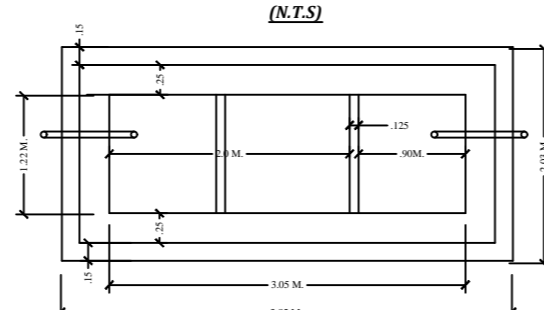

PLAN
DETAIL OF SEPTIC TANK

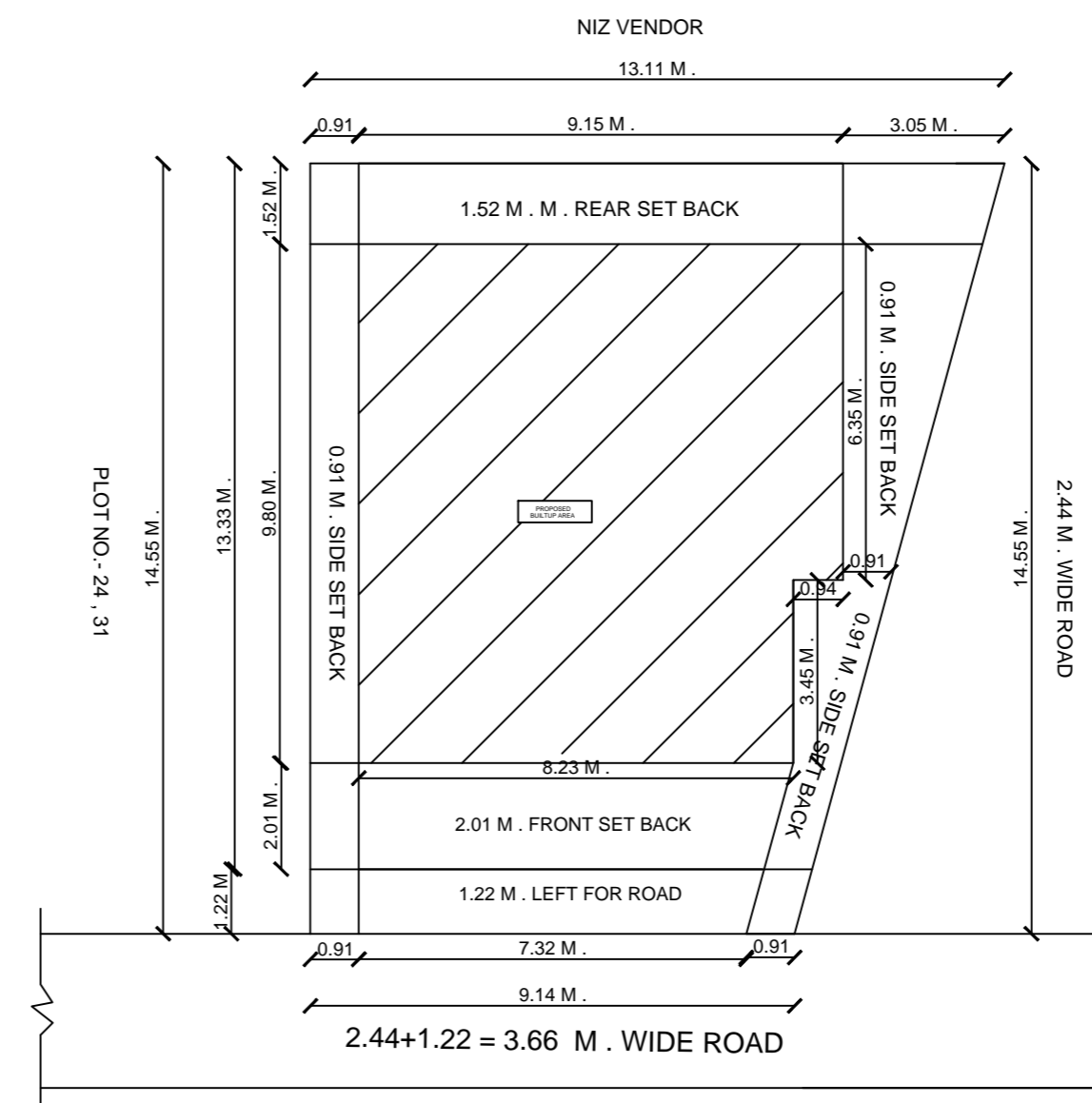

SITE PLAN

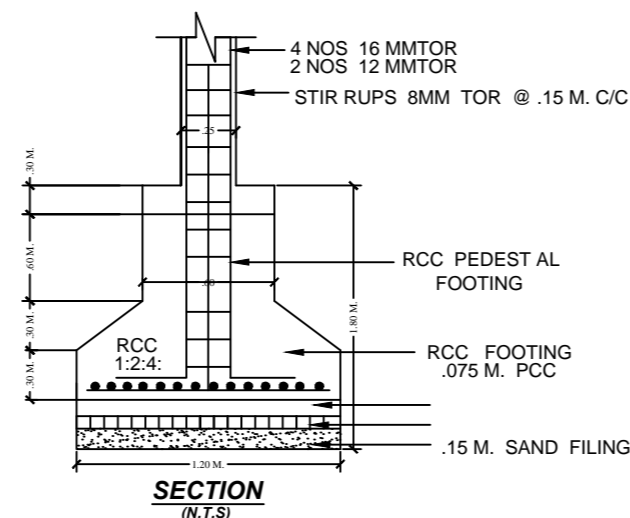

SECTION (N.T.S.)

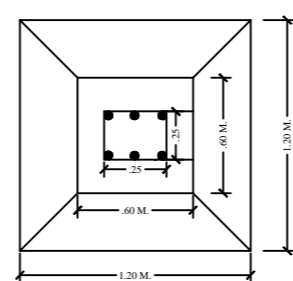

PLAN

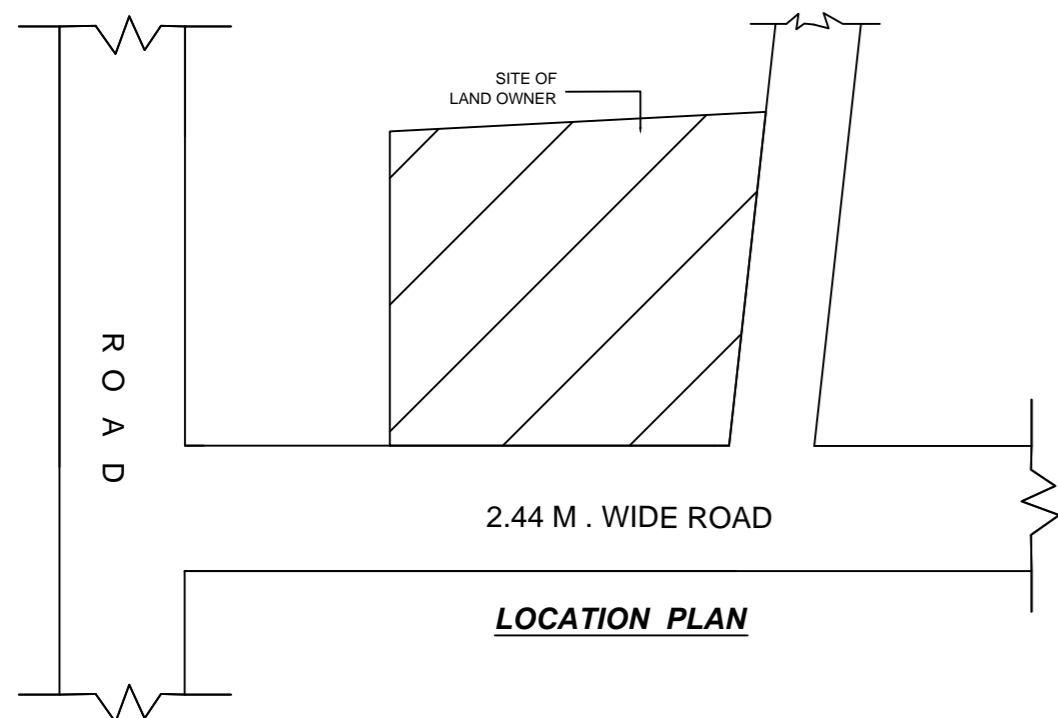

LOCATION PLAN

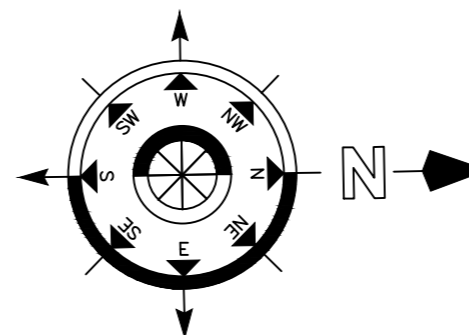

MAP APPROVED BY

SIGNATURE OF APPLICANT

SIGNATURE OF ENGINEER

TOTAL PLOT AREA	=	161.87	SQM.
NET PLOT AREA	=	148.29	SQM.
TOTAL OPEN LAND AREA	=	61.86	SQM.
GROUND FLOOR B/A	=	86.43	SQM.
TOTAL B/A	=	86.43	SQM.
F.A.R.	=	0.58	
% OF COVERED AREA	=	58 %	
BUILDING HEIGHT	=	3.96 M.	

PROPOSED RESIDENTIAL BUILDING OF
 NAME- SMT. YASHODA DEVI
 S/O. - SRI RAM LOCHAN YADAV
 MAUZA- LATEHAR
 P.S. - LATEHAR
 P.S. NO.- 250
 WARD NO.- 08
 KHATA NO.- 18 & 67
 PLOT NO.- 23 & 25
 HOLDING NO.- 04
 TOUZI NO.- 51
 DIST. - LATEHAR (JHARKHAND)