

SITE PLAN (Scale - 1:200)

FAR & Tenement Details (Table 4c-1)

Building	No. of Same Bldg	Total Built Up Area (Sq.mt.)	Proposed FAR Area (Sq.mt.) Resi.	Total FAR Area (Sq.mt.)	Total Consumed Additional FAR Area (Sq.mt.)	Tnmt (No.)
A (SMT SITA DEVI)	1	99.68	99.68	99.68	99.68	01
Grand Total :	1	99.68	99.68	99.68	99.68	01

Proposal Basic Information

Proposal File No.	LNPC/BP0034/W02/2023
Owner Name	Sita Devi
Khata No	38
Plot No	242
Village Name	Banpur
Use	Residential
SubUse	Bungalow/ Dwelling / Non Apartment

AREA STATEMENT LATEHAR NAGAR PANCHAYAT		VERSION NO.: 1.0.66
PROJECT DETAIL:		VERSION DATE: 16/10/2020
Region: JHARKHAND URBAN LOCAL BODIES	Plot Use: Residential	
District: LATEHAR	Plot SubUse: Bungalow/ Dwelling / Non Apartment	
Authority: LATEHAR NAGAR PANCHAYAT	PlotNearbyReligiousStructure: NA	
Inward_No: LNPCI/BP0034/W02/2023	PlotSubPlot No: 242	
Application Type: General Proposal	North: Road Width - 3.66	
Project Type: Building Permission	South: Plot No. - NIZ VENDOR	
Nature of Development: New	East: Plot No. - NIZ VENDOR	
Location of Development Area: Old Area	West: Plot No. - NIZ VENDOR	
AREA DETAILS:		
AREA OF PLOT (Minimum)	(A)	SQ.MT. 609.90
NET AREA OF PLOT(Gross Plot Area - Deduction from Gross Plot area)	(A-Deductions)	609.90
Deduction for Balance Plot Area(from Gross Plot Area)		
Common Plot		91.63
Total		91.63
BALANCE AREA OF PLOT(Net Plot Area - Recreational/Amenity space)	(A-Deductions)	518.27
PLOT AREA FOR COVERAGE(Net Plot Area)	(A-Deductions)	609.90
Plot Area for FAR (Net Plot Area + Road Widening Area)	(A-Deductions)	609.90
COVERAGE CHECK		
Permissible Coverage area (60.00 %)		365.94
Proposed Coverage Area (16.34 %)		99.68
Total Prop. Coverage Area (16.34 %)		99.68
Balance coverage area (43.66 %)		266.26
FAR CHECK		
Perm. FAR Area (1.500)		914.85
Total Perm. FAR area		914.85
Residential FAR		99.68
Proposed FAR Area		99.68
Total Proposed FAR Area		99.68
Consumed FAR (Factor)		0.16
Balance FAR Area		815.17
BUILT UP AREA CHECK		
Total Proposed BuiltUp Area		99.68
ARCHITECT (Regd)	law chaturvedi	
ENGINEER (Regd)		
SUPERVISOR (Regd)		
OWNER (Regd)	Sita Devi	
DEVELOPMENT AUTHORITY		LOCAL BODY

COLOR INDEX

PLOT BOUNDARY	Black
ABUTTING ROAD	Green
PROPOSED CONSTRUCTION	Red
COMMON PLOT	Yellow
ROAD WIDENING AREA	Blue
EXISTING (To be retained)	Light Blue
EXISTING (To be demolished)	Light Yellow

Buildingwise Floor FAR Details

Floor Name	Building Name A (SMT SITA DEVI)		Total	
	Proposed Built Up Area (Sq.mt.)	Proposed FAR Area (Sq.mt.)	Total Proposed Built Up Area (Sq.mt.)	Total FAR Area (Sq.mt.)
Ground Floor	99.68	99.68	99.68	99.68
Terrace Floor	0.00	0.00	0.00	0.00
Total :	99.68	99.68	99.68	99.68

Building USE/SUBUSE Details

Building Name	Building Use	Building SubUse	Building Structure
A (SMT SITA DEVI)	Residential	Bungalow/ Dwelling / Non Apartment	Non-Highrise

LTP NAME AND SIGNATURE	STRUCTURAL ENG'S NAME AND SIGNATURE	BUILDER NAME AND SIGNATURE	DIGITAL SIGNATURE
law chaturvedi LNPC/ENG/0004/2018			

Proposal Basic Information	
Proposal File No.	LNPC/BP/0034/W02/2023
Owner Name	Sita Devi
Khata No	38
Plot No	242
Village Name	Banpur
Use	Residential
SubUse	Bungalow/ Dwelling / Non Apartment

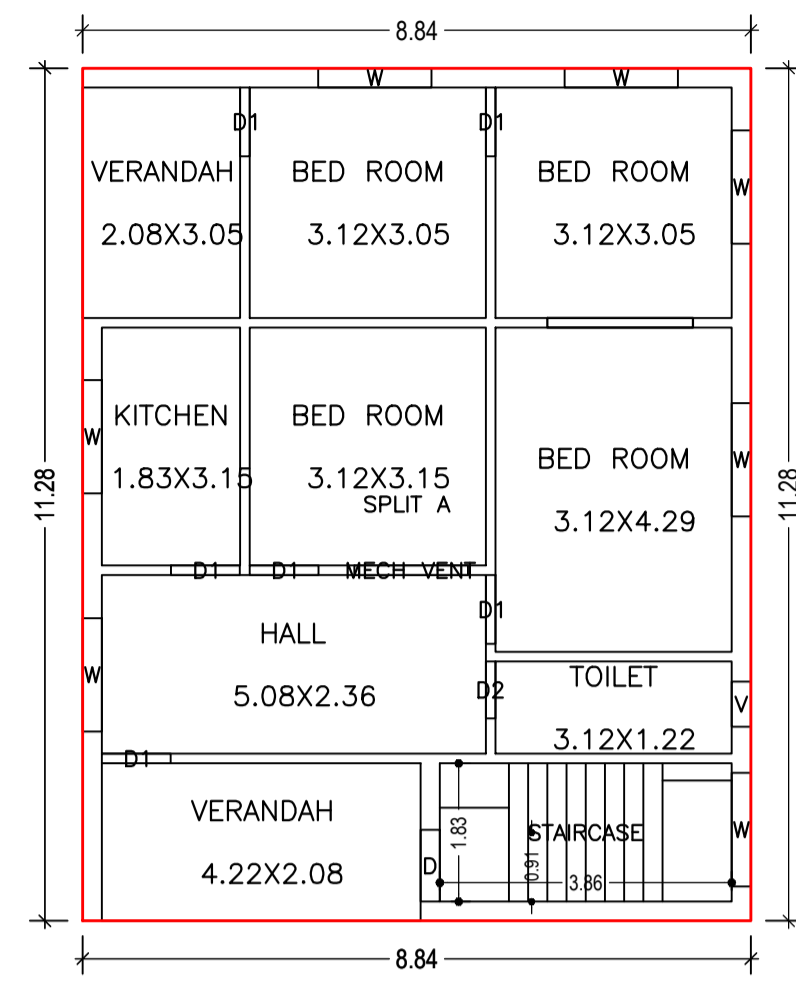

GROUND FLOOR PLAN (Proposed) (SCALE 1:100)

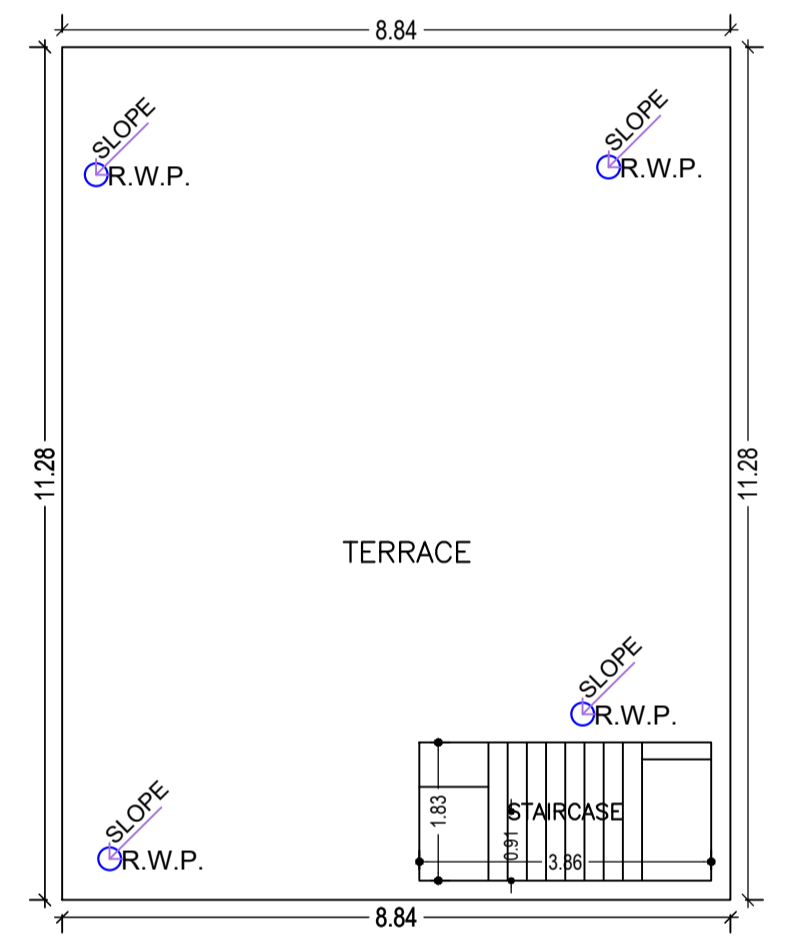

TERRACE FLOOR PLAN (SCALE 1:100)

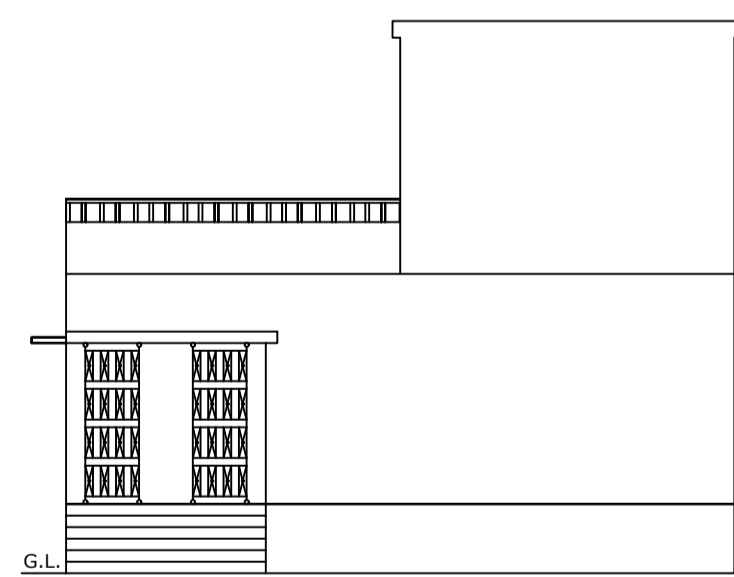

FRONT ELEVATION

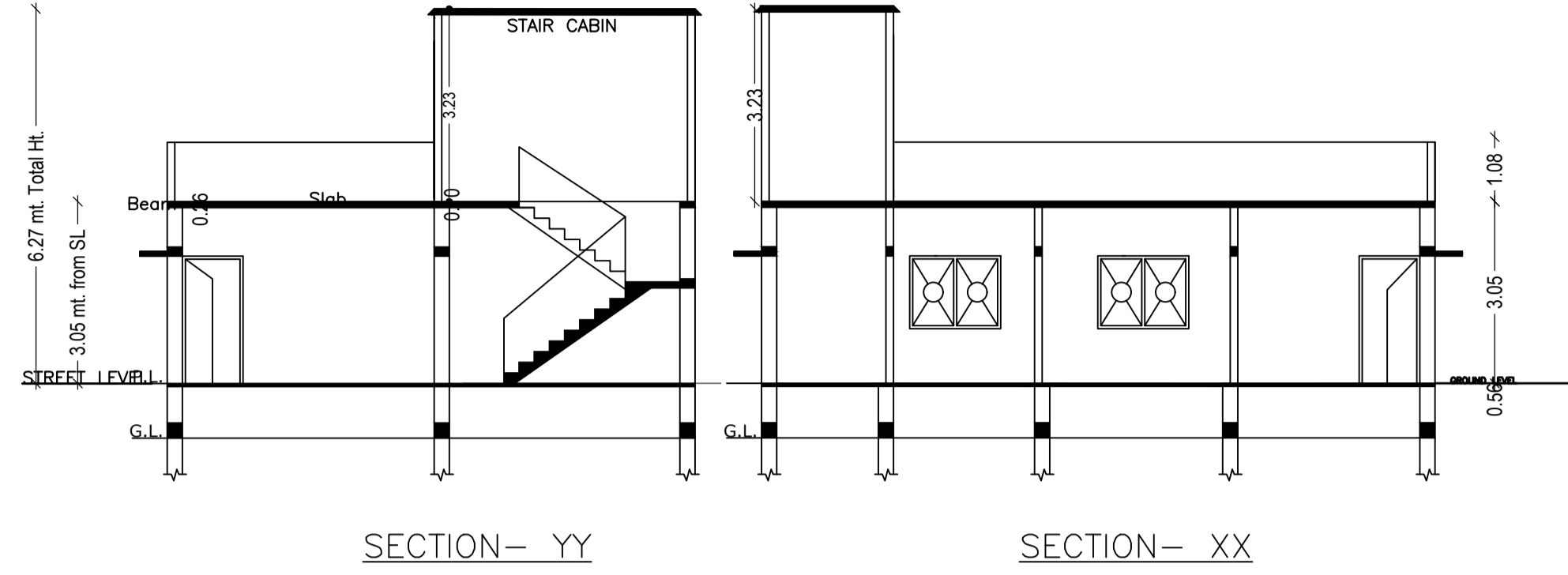

SECTION-YY

SECTION-XX

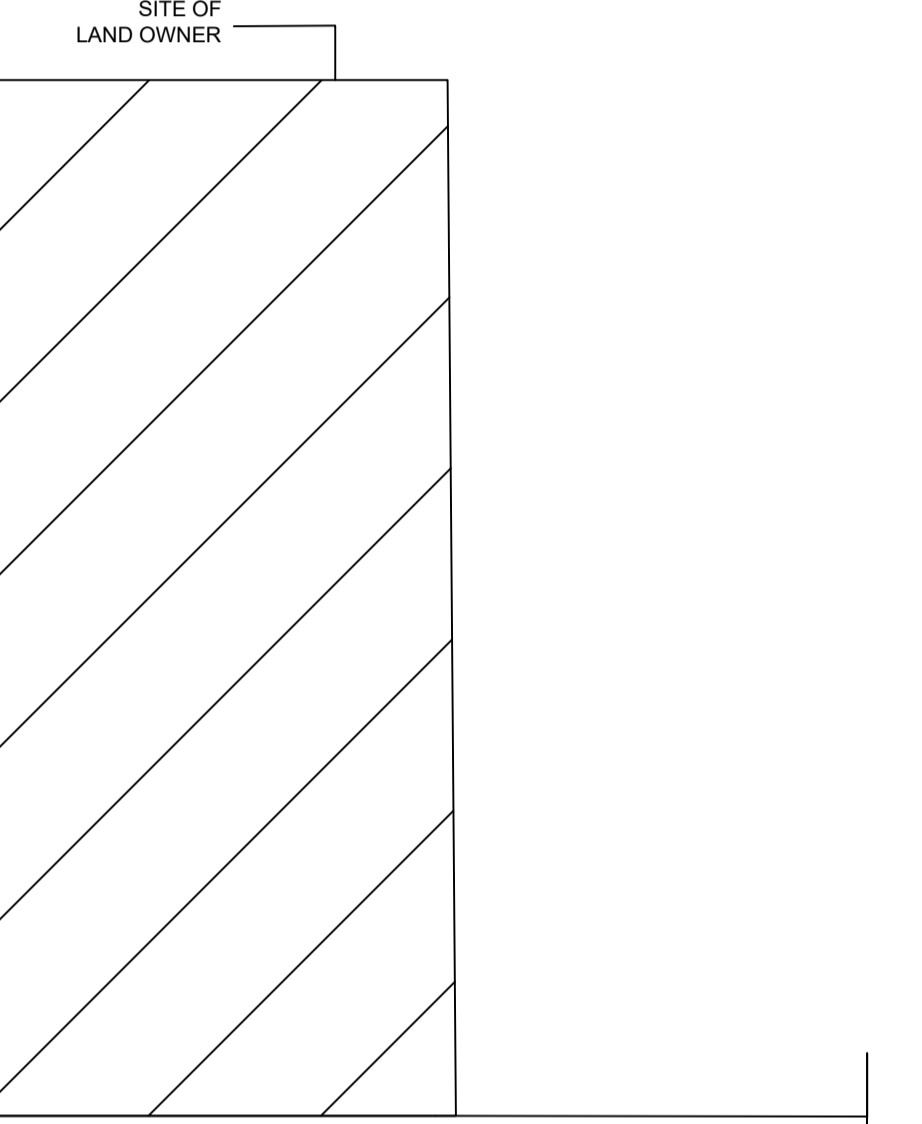
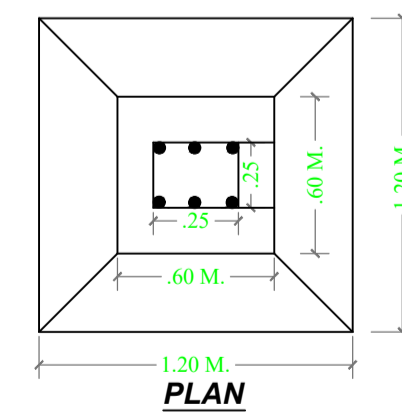
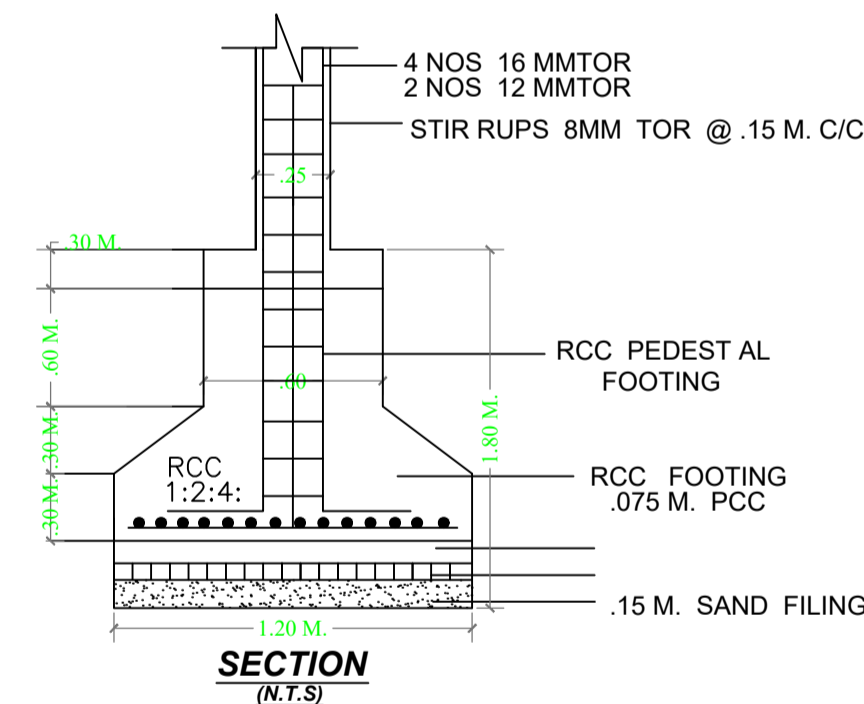
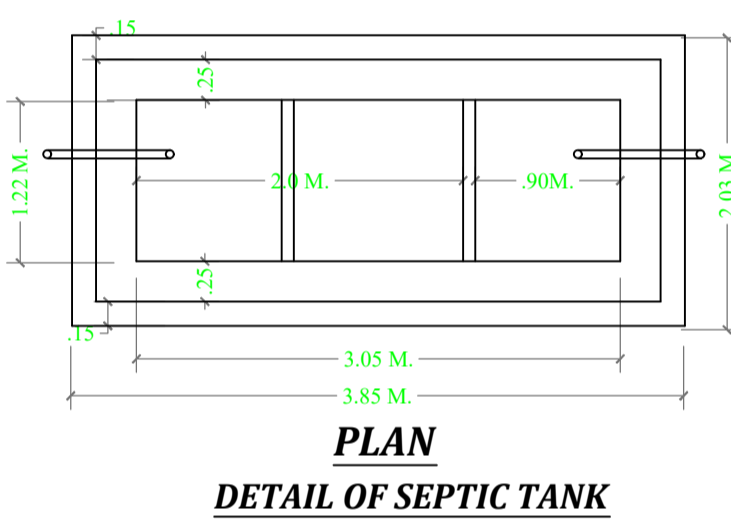
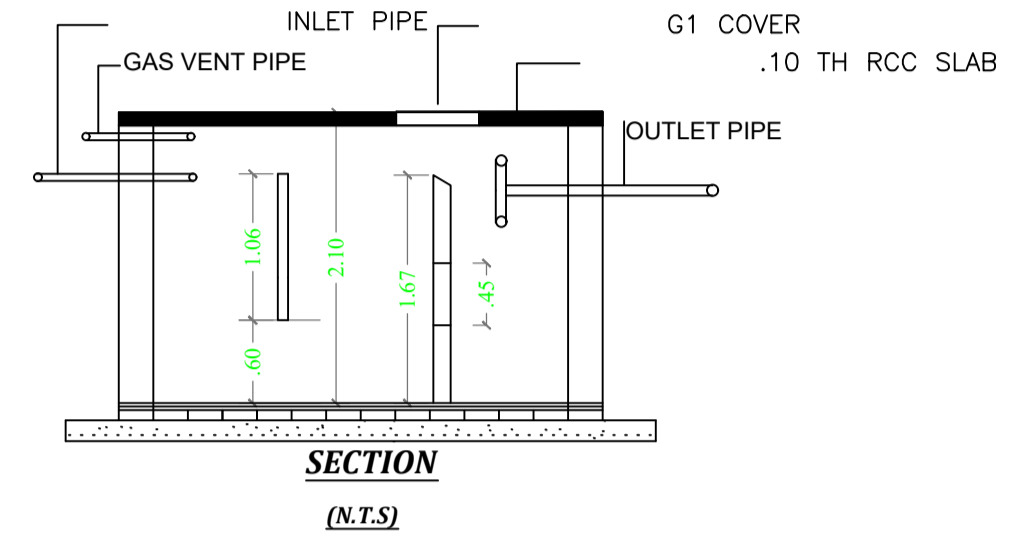

3.66 M . WIDE ROAD

LOCATION PLAN

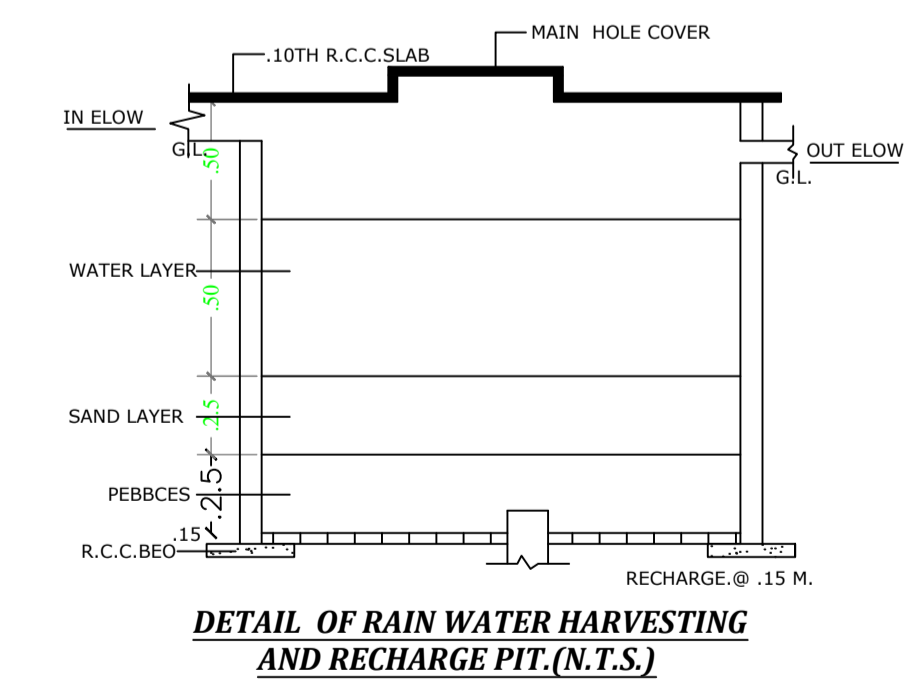

DETAIL OF RAIN WATER HARVESTING AND RECHARGE PIT (N.T.S)

Building :A (SMT SITA DEVI)

Floor Name	Total Built Up Area (Sq.mt.)	Proposed FAR Area (Sq.mt.) Resi.	Total FAR Area (Sq.mt.)	Total Consumed Additional FAR Area (Sq.mt.)	Tnmt (No.)
Ground Floor	99.68	99.68	99.68	99.68	01
Terrace Floor	0.00	0.00	0.00	0.00	00
Total :	99.68	99.68	99.68	99.68	01
Total Number of Same Buildings	1				
Total :	99.68	99.68	99.68	99.68	01

SCHEDULE OF DOOR:

BUILDING NAME	NAME	LENGTH	HEIGHT	NOS
A (SMT SITA DEVI)	D2	0.75	2.13	01
A (SMT SITA DEVI)	D1	0.91	2.13	06
A (SMT SITA DEVI)	D	0.95	2.13	01

SCHEDULE OF WINDOW/VENTILATION:

BUILDING NAME	NAME	LENGTH	HEIGHT	NOS
A (SMT SITA DEVI)	V	0.60	2.70	01
A (SMT SITA DEVI)	W	1.50	2.70	07
A (SMT SITA DEVI)	MECH VENT	1.50	2.70	01

UnitBUA Table for Building :A (SMT SITA DEVI)

FLOOR	Name	UnitBUA Type	UnitBUA Area	Carpet Area	No. of Rooms	No. of Tenement
GROUND FLOOR PLAN	SPLIT A	FLAT	83.52	83.28	9	1
Total:	-	-	83.52	83.28	9	1

LTP NAME AND SIGNATURE	STRUCTURAL ENG'S NAME AND SIGNATURE	BUILDER NAME AND SIGNATURE	DIGITAL SIGNATURE
law chaturvedi LNPC/ENG/0004/2018			

Proposal Basic Information	
Proposal File No.	LNPC/BP/0034/W02/2023
Owner Name	Sita Devi
Khata No	38
Plot No	242
Village Name	Banpur
Use	Residential
SubUse	Bungalow/ Dwelling / Non Apartment

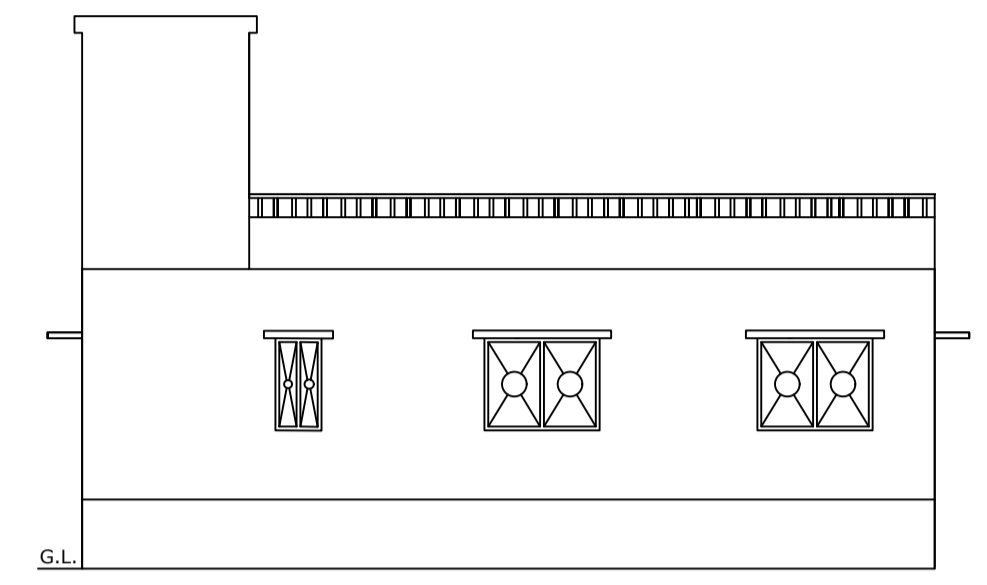

WEST SIDE ELEVATION

LTP NAME AND SIGNATURE	STRUCTURAL ENG'S NAME AND SIGNATURE	BUILDER NAME AND SIGNATURE	DIGITAL SIGNATURE
law chaturvedi LNPC/ENG/0004/2018			