

FRONT ELEVATION

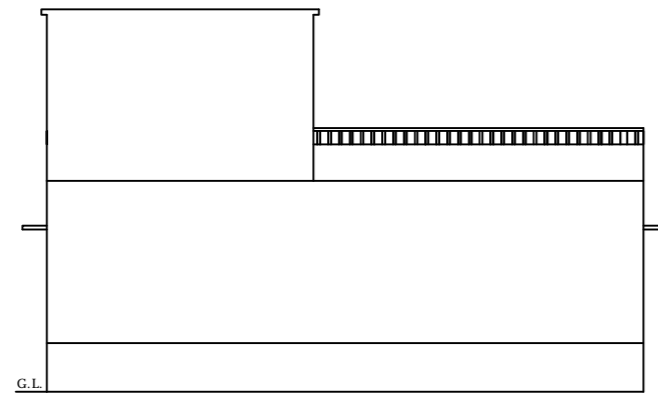

NORTH SIDE ELEVATION

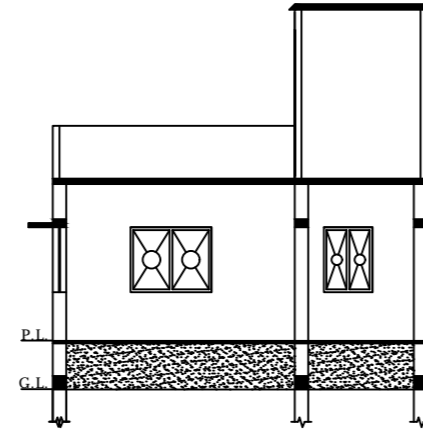

SECTION- YY

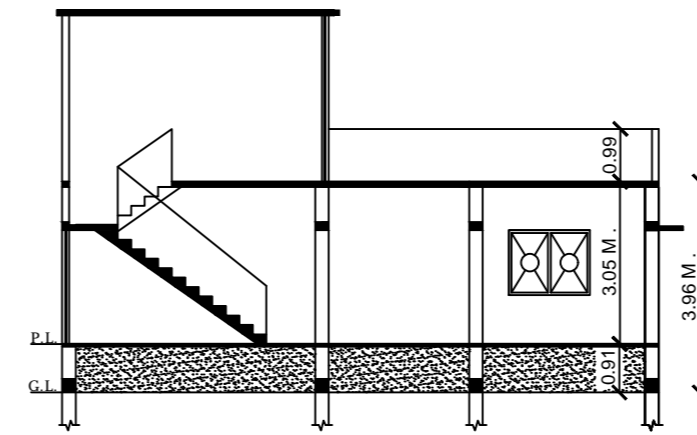

SECTION- XX

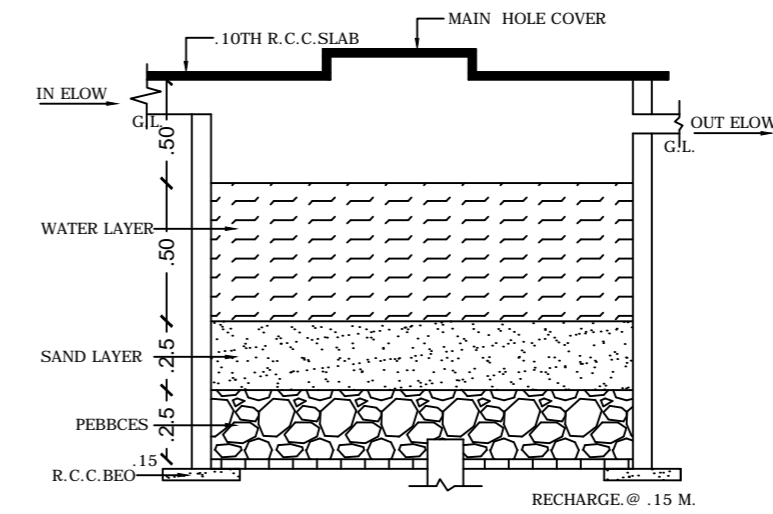

DETAIL OF RAIN WATER HARVESTING AND RECHARGE PIT.(N.T.S)

SCHEDULE OF DS & WS		
TYPE	SIZE	REMARKS
D	1.06 M.X2.10 M.	F PANELED
D1	0.06 M.X2.10 M.	F PANELED
D2	0.75 M.X2.10 M.	F PANELED
W	1.50 M.X1.20 M.	F GLAZZED
W1	1.20 M.X1.20 M.	F GLAZZED
W2	0.91 M.X1.20 M.	F GLAZZED
C.GATE	2.10 M.X2.10 M.	IRON

SPECIFICATION

1. DETAIL OF R.C.C. FOOTING COLUMN FON (M.25)
2. 1ST CLASS BRICK WORK IN CEMENT PLASTER (1:6)
3. 1.25X.15TH. R.C.C. LINTEL BAND OVER DOOR'S & WINDOW'S
4. 10TH. LIME CON. TERR.OVER .10TH. R.C.C. ROOF SLAB(M.25)
5. SAL WOOD FRAME & SUAM WOOD SHUTTER.
6. 0.012TH. IN CEMENT PLASTER IN BOTH SIDE WACC (1:6)
7. MARBLE OR MOSAIC FLOORING OVER .110TH. DRY RAMMED KHOA OVER B.F. SOILING . OVER LOCAL SAND FILLING .
8. 2 CUAT OF WHITE & COLOUR WASH AS PER CHOICE.
9. 17CM.WIDE & 30 CM. PUCCA DRAIN AROUND THE BUILDING .

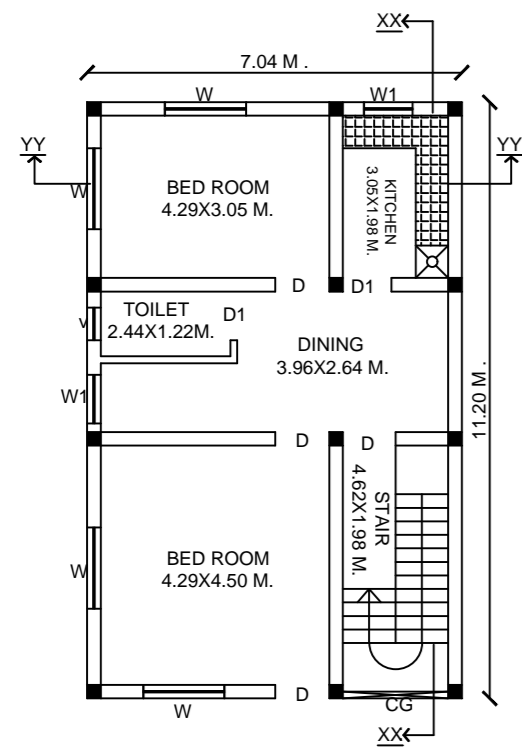

PROPOSED GROUND FLOOR PLAN

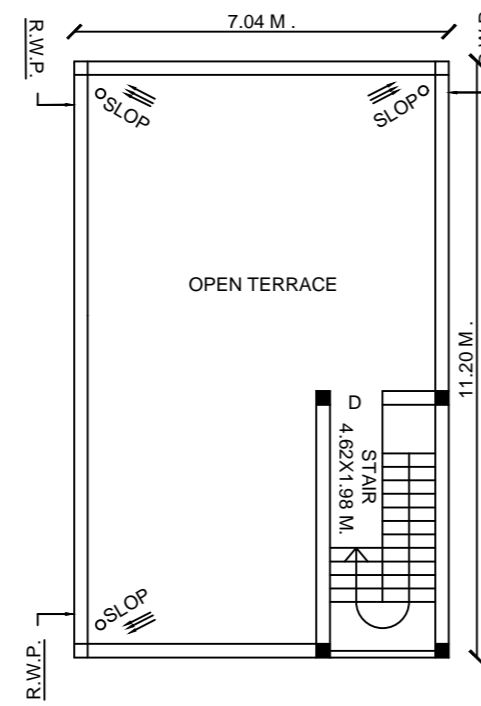

TERRACE FLOOR PLAN

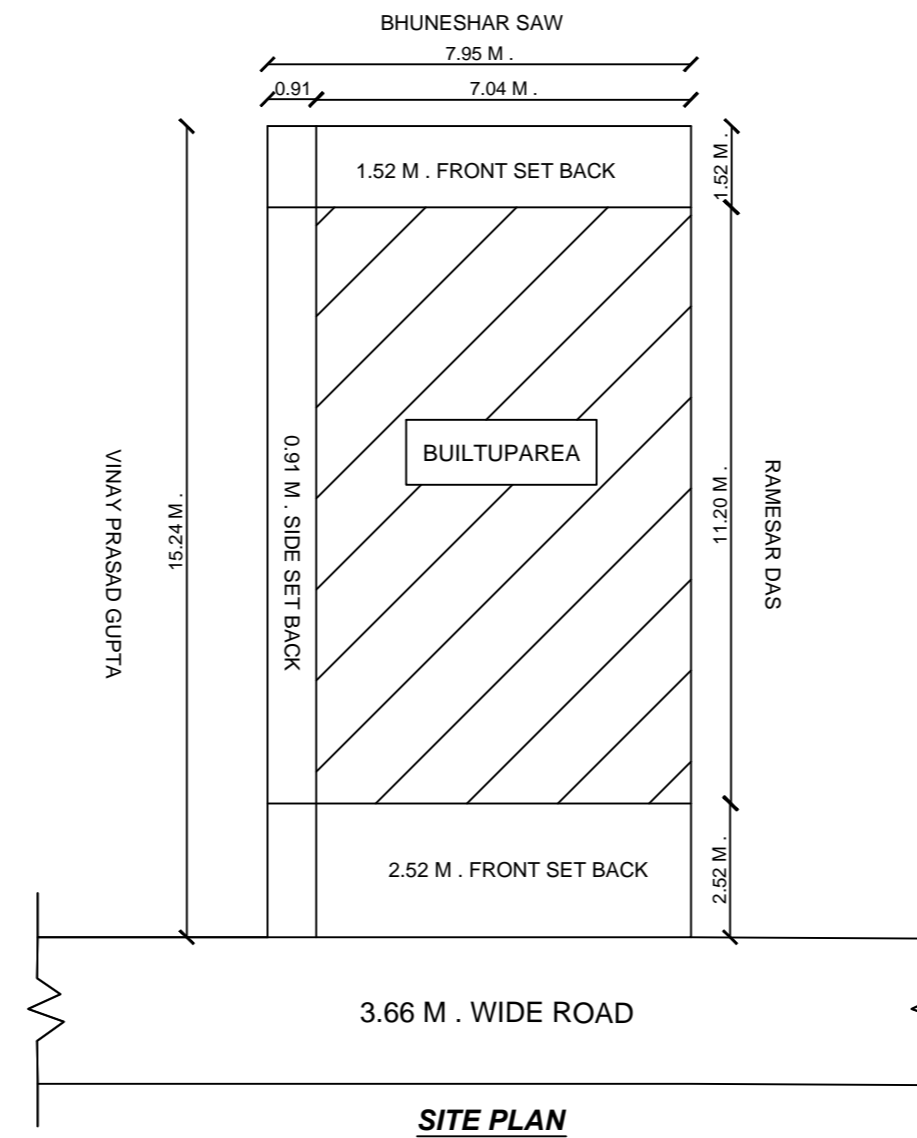

SITE PLAN

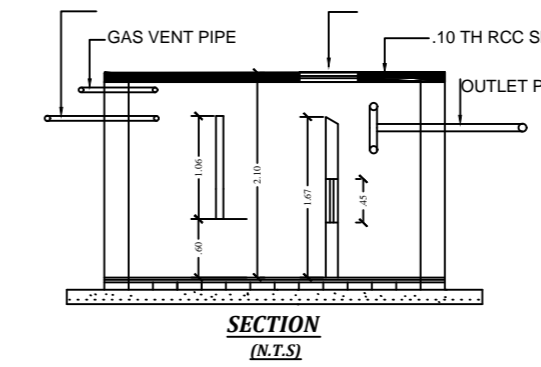

SECTION (N.T.S)

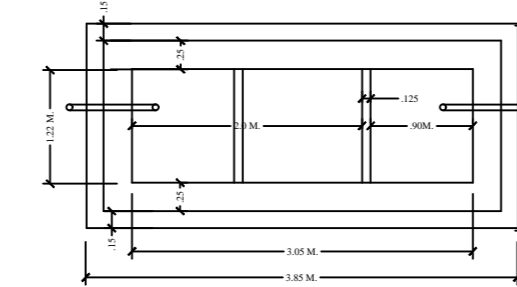

PLAN DETAIL OF SEPTIC TANK

TOTAL PLOT AREA	=	121.16 SQM.
NET PLOT AREA	=	121.16 SQM.
TOTAL OPEN LAND AREA	=	42.31 SQM.
PRO.GROUND FLOOR B/A	=	78.85 SQM.
TOTAL B/A	=	78.85 SQM.
F.A.R.	=	0.65
% OF COVRED AREA	=	65 %
BUILDING HEIGHT	=	3.96 M.

PROPOSED RESIDENTIAL BUILDING OF
 NAME- SRI VIJAY KUMAR SAHU
 S/O - LATE CHATURGUJ PRASAD SAHU
 MAUZA LATEHAR
 P.S. - LATEHAR
 P.S. NO.- 250
 WARD NO.- 01
 KHATA NO.- 85
 H. NO.-
 PLOT NO.- 667
 TOUZI NO.- 51
 DIST. - LATEHAR (JHARKHAND)

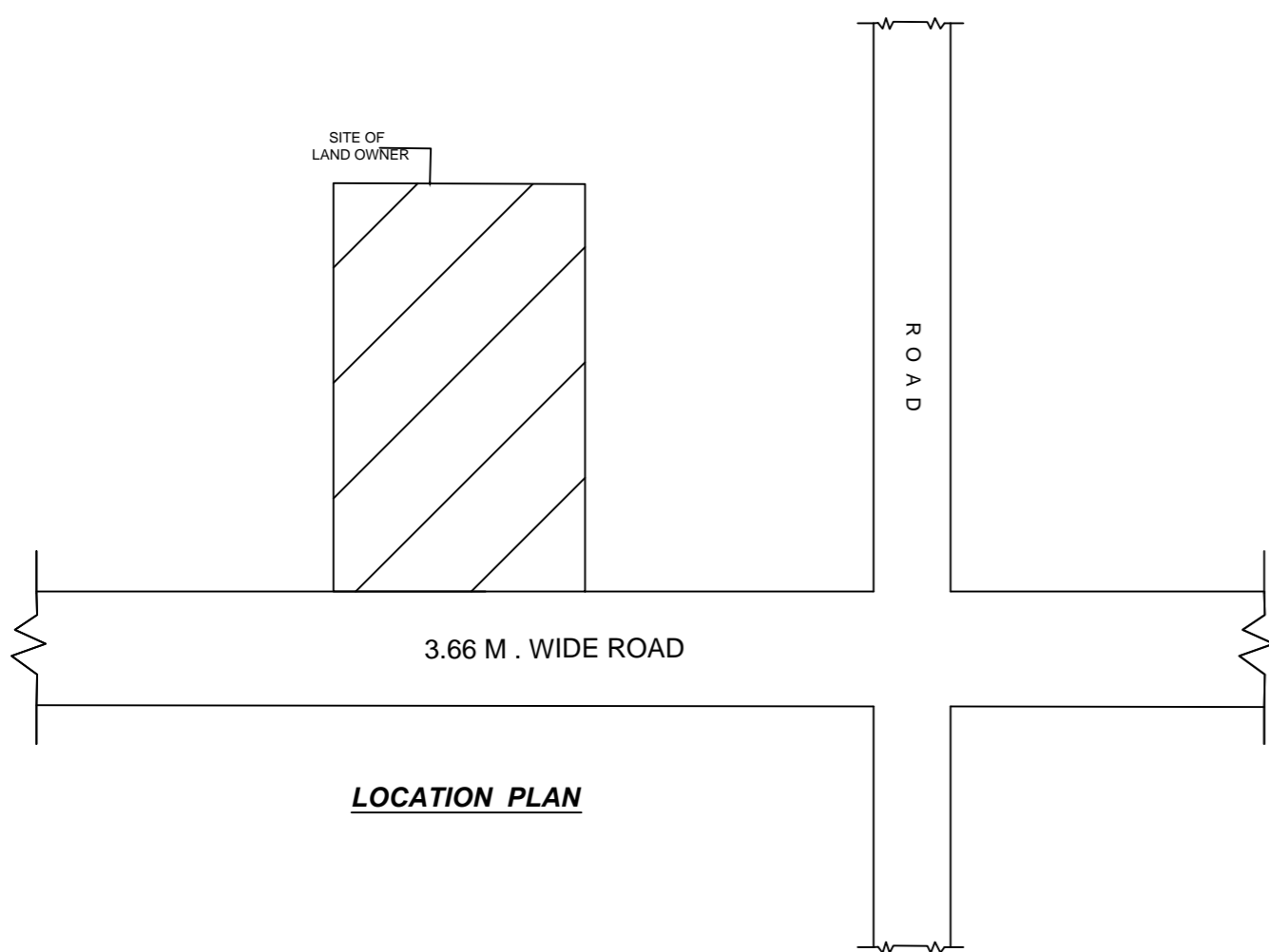
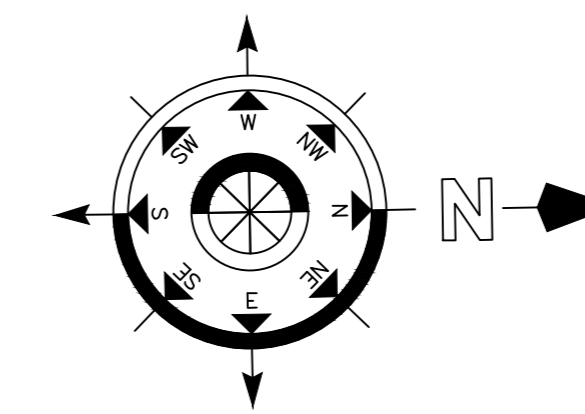

LOCATION PLAN

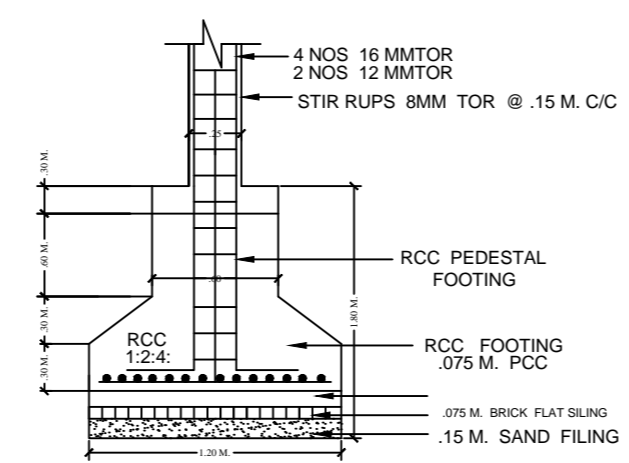

SECTION (N.T.S)

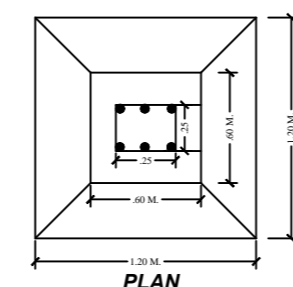

PLAN

MAP APPROVED BY

SIGNATURE OF APPLICANT

SIGNATURE OF ENGINEER