

FAR & Tenement Details (Table 4c-1)

Building	No. of Same Bldg	Total Built Up Area (Sq.mt.)	Proposed FAR Area (Sq.mt.)	Total FAR Area (Sq.mt.)	Total Consumed Additional FAR Area (Sq.mt.)	Tnmt (No.)
A (KAVITA)	1	36.39	36.39	36.39	36.39	01
Grand Total :	1	36.39	36.39	36.39	36.39	01

Proposal Basic Information

Proposal File No.	LNPC/ENG/0004/2018
Owner Name	Kabita Devi
Khata No	39
Plot No	708
Village Name	Latehar
Use	Residential
SubUse	Bungalow/ Dwelling / Non Apartment

AREA STATEMENT LATEHAR NAGAR PANCHAYAT

VERSION NO. : 1.0.73
VERSION DATE: 16/10/2020

PROJECT DETAIL	Plot Use	SQ. MT.
Region: JHARKHAND URBAN LOCAL BODIES	Residential	
District: LATEHAR	Plot SubUse: Bungalow/ Dwelling / Non Apartment	
Authority: LATEHAR NAGAR PANCHAYAT	PlotNearbyReligiousStructure: NA	
Inward No: LNPCI/BP/0026/W06/2024	PlotSubPlot No: 708	
Application Type: General Proposal	North: Road Width - 3.66	
Project Type: Building Permission	South: Survey No. - HALKHORI SAW	
Nature of Development: New	East: Plot No. - ABHINANDAN PRASAD	
Location of Development Area: Old Area	West: Plot No. - MUKESH PRASAD	

AREA DETAILS:		SQ. MT.
AREA OF PLOT (Minimum)	(A)	83.61
NET AREA OF PLOT(Gross Plot Area - Deduction from Gross Plot area)	(A-Deductions)	83.61
Deduction for Balance Plot Area(from Gross Plot Area)		
Common Plot		5.57
Total		5.57
BALANCE AREA OF PLOT(Net Plot Area - Recreational/Amenity space)	(A-Deductions)	78.04
PLOT AREA FOR COVERAGE(Net Plot Area)	(A-Deductions)	83.61
Plot Area for FAR (Net Plot Area + Road Widening Area)	(A-Deductions)	83.61
COVERAGE CHECK		
Permissible Coverage area (70.00 %)		58.53
Proposed Coverage Area (43.52 %)		36.39
Total Prop. Coverage Area (43.52 %)		36.39
Balance coverage area (26.48 %)		22.14
FAR CHECK		
Perm. FAR Area (1.500)		125.42
Total Perm. FAR area		125.42
Residential FAR		36.39
Proposed FAR Area		36.39
Total Proposed FAR Area		36.39
Consumed FAR (Factor)		0.44
Balance FAR Area		89.03
BUILT UP AREA CHECK		
Total Proposed BuiltUp Area		36.39
ARCHITECT (Regd)	law chaturvedi	
ENGINEER (Regd)		
SUPERVISOR (Regd)		
OWNER (Regd)	kabita devi	
DEVELOPMENT AUTHORITY		LOCAL BODY

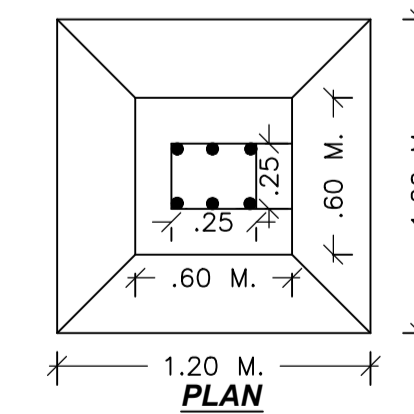
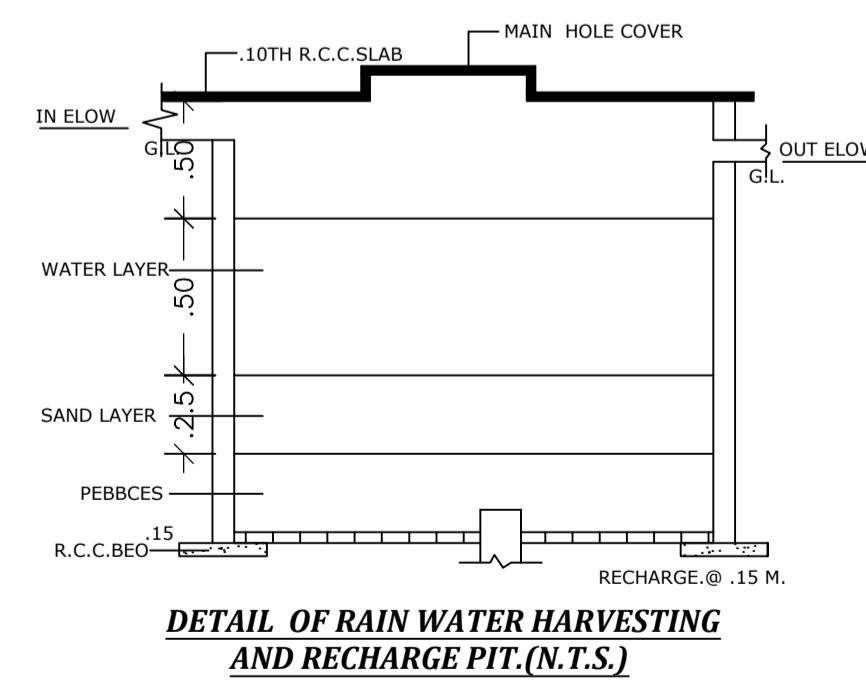
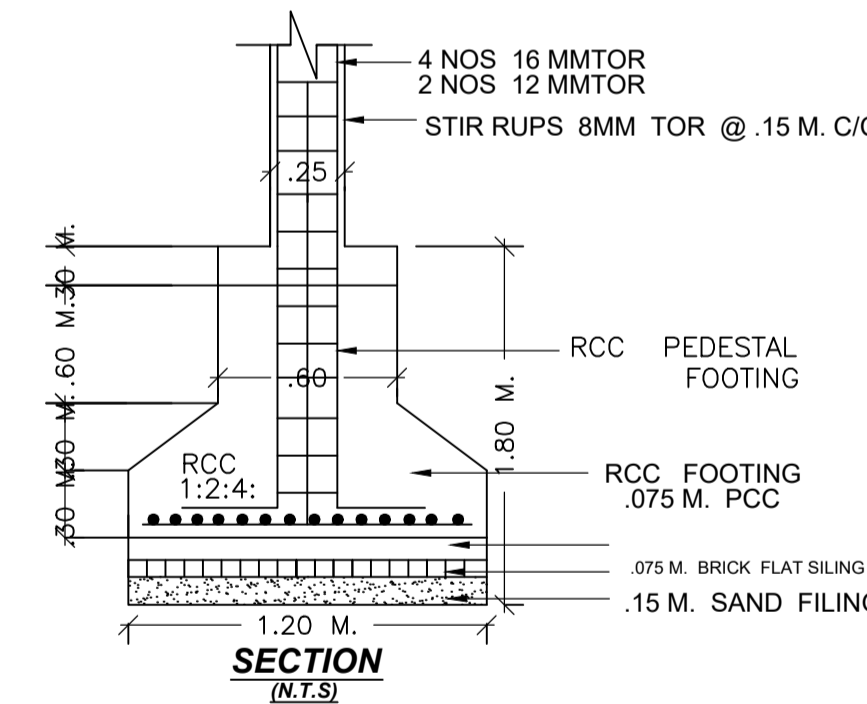
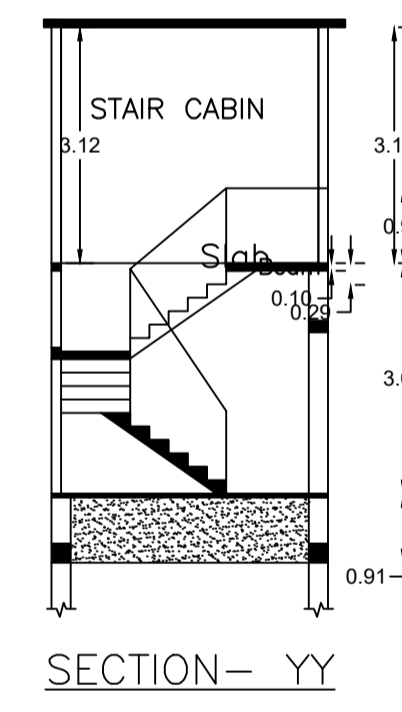
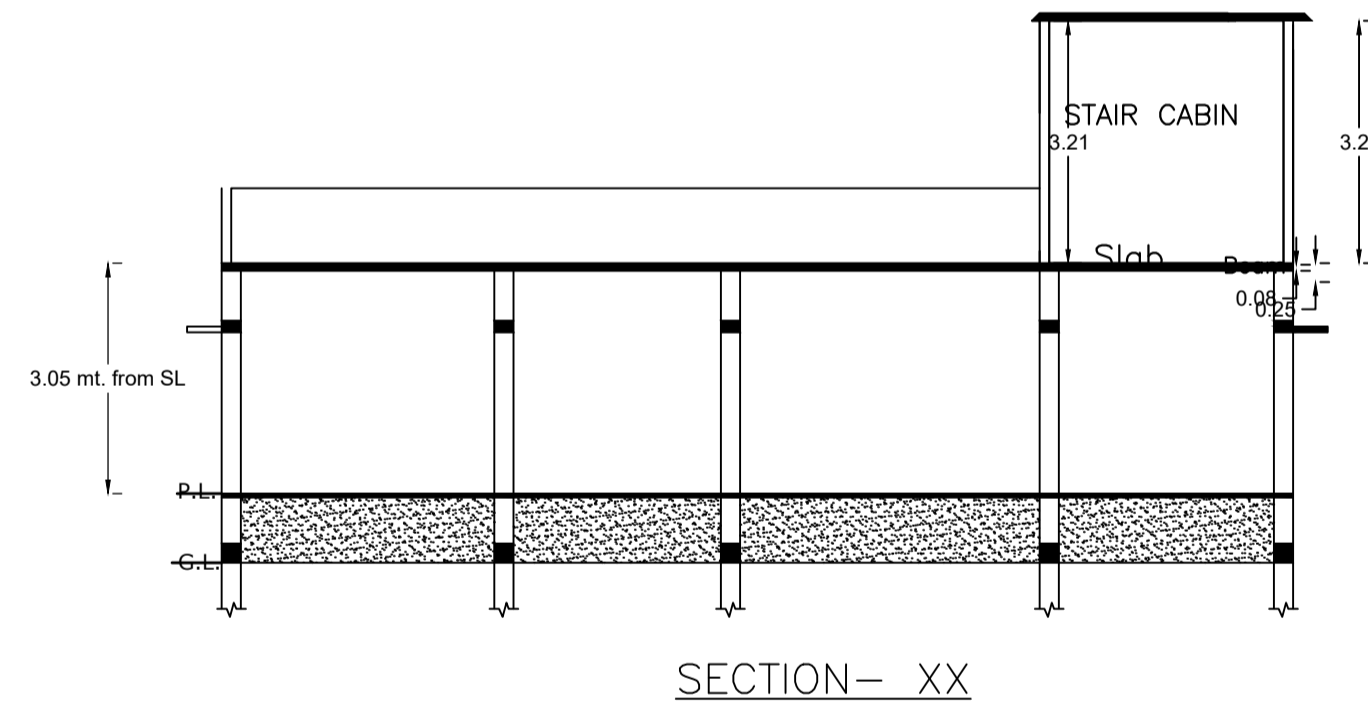
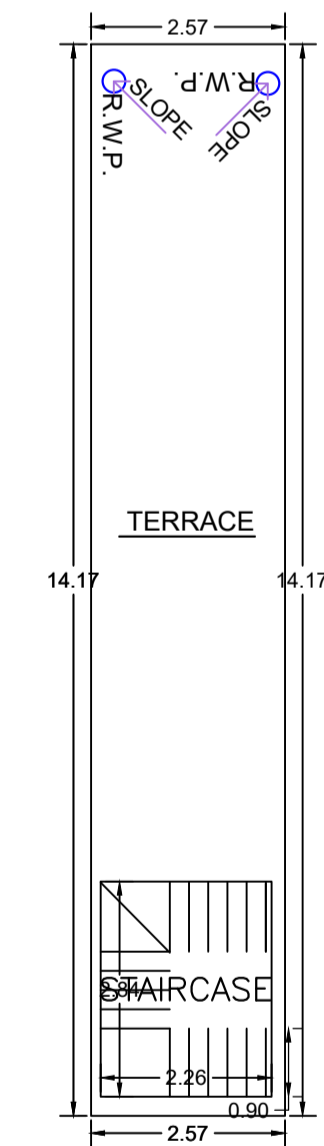
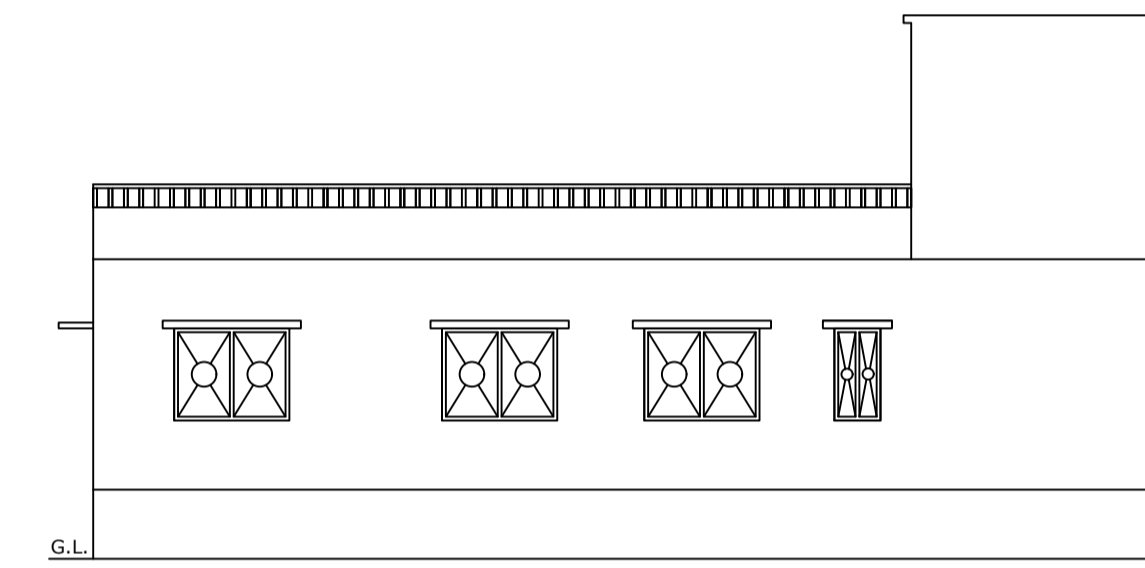
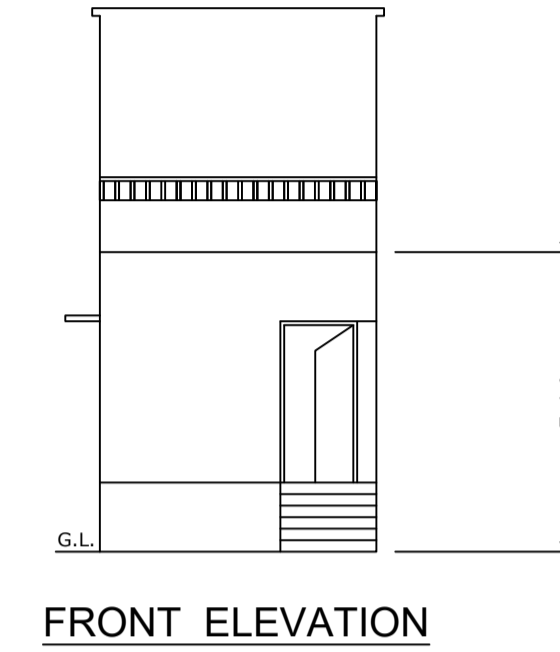

COLOR INDEX

PLOT BOUNDARY	Black
ABUTTING ROAD	Green
PROPOSED CONSTRUCTION	Red
COMMON PLOT	Yellow
ROAD WIDENING AREA	Blue
EXISTING (To be retained)	Orange
EXISTING (To be demolished)	Light Blue

Buildingwise Floor FAR Details

Floor Name	Building Name A (KAVITA)		Total	
	Proposed Built Up Area (Sq.mt.)	Proposed FAR Area (Sq.mt.)	Total Proposed Built Up Area (Sq.mt.)	Total FAR Area (Sq.mt.)
Ground Floor	36.39	36.39	36.39	36.39
Terrace Floor	0.00	0.00	0.00	0.00
Total :	36.39	36.39	36.39	36.39

Building USE/SUBUSE Details

Building Name	Building Use	Building SubUse	Building Structure	Floor Name	Floor Use	Floor SubUse	FAR Name	FAR Use	FAR SubUse
A (KAVITA)	Residential	Bungalow/ Dwelling / Non Apartment	Non-Highrise	GROUND FLOOR PLAN	Residential	Bungalow/ Dwelling / Non Apartment	Residential	Residential	Bungalow/ Dwelling / Non Apartment
A (KAVITA)	Residential	Bungalow/ Dwelling / Non Apartment	Non-Highrise	TERRACE FLOOR PLAN	Residential	Bungalow/ Dwelling / Non Apartment	-	-	-

Building :A (KAVITA)

Floor Name	Total Built Up Area (Sq.mt.)	Proposed FAR Area (Sq.mt.)	Total FAR Area (Sq.mt.)	Total Consumed Additional FAR Area (Sq.mt.)	Tnmt (No.)
Ground Floor	36.39	36.39	36.39	36.39	01
Terrace Floor	0.00	0.00	0.00	0.00	00
Total :	36.39	36.39	36.39	36.39	01
Total Number of Same Buildings	1				
Total :	36.39	36.39	36.39	36.39	01

SCHEDULE OF DOOR:

BUILDING NAME	NAME	LENGTH	HEIGHT	NOS
A (KAVITA)	D	0.90	2.10	01

SCHEDULE OF WINDOW/VENTILATION:

BUILDING NAME	NAME	LENGTH	HEIGHT	NOS
A (KAVITA)	W	0.61	1.20	01
A (KAVITA)	W	1.52	1.20	04

UnitBUA Table for Building :A (KAVITA)

FLOOR	Name	UnitBUA Type	UnitBUA Area	Carpet Area	No. of Rooms	No. of Tenement
GROUND FLOOR PLAN	SPLIT A	FLAT	23.13	23.10	1	1
Total:	-	-	23.13	23.10	1	1

LTP NAME AND SIGNATURE	STRUCTURAL ENG'S NAME AND SIGNATURE	BUILDER NAME AND SIGNATURE	DIGITAL SIGNATURE
law chaturvedi LNPC/ENG/0004/2018			