

FRONT ELEVATION

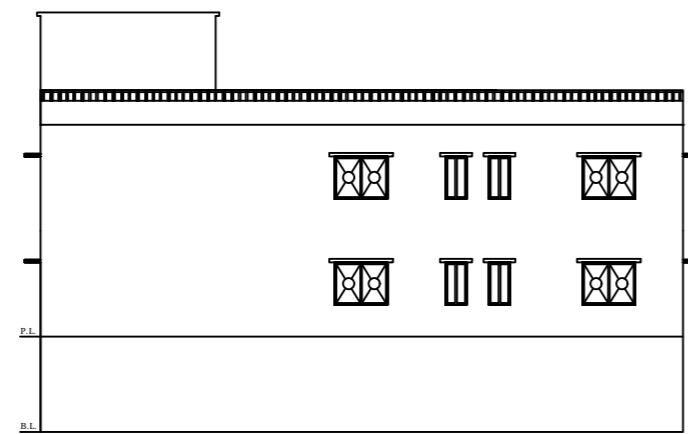

NORTH SIDE ELEVATION

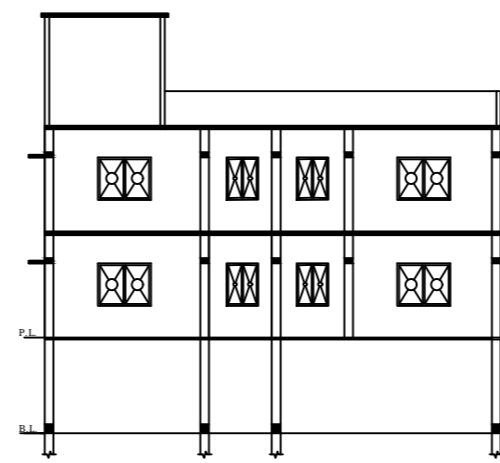

SECTION-YY

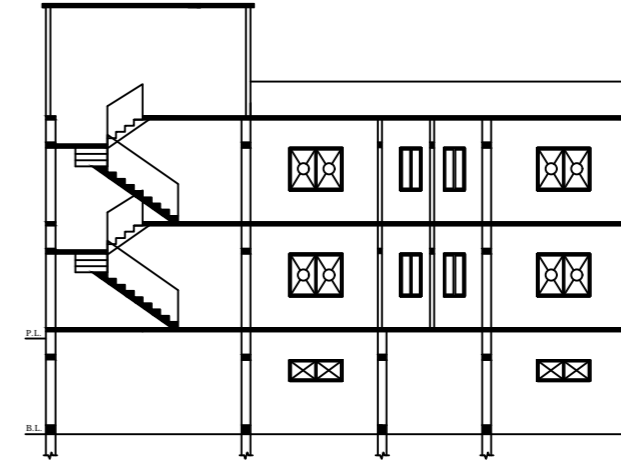

SECTION-XX

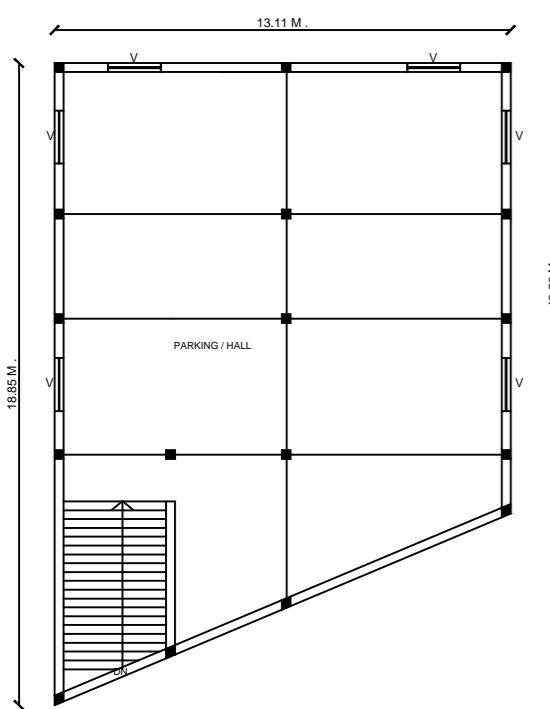

PROPOSED BASMENT FLOOR PLAN

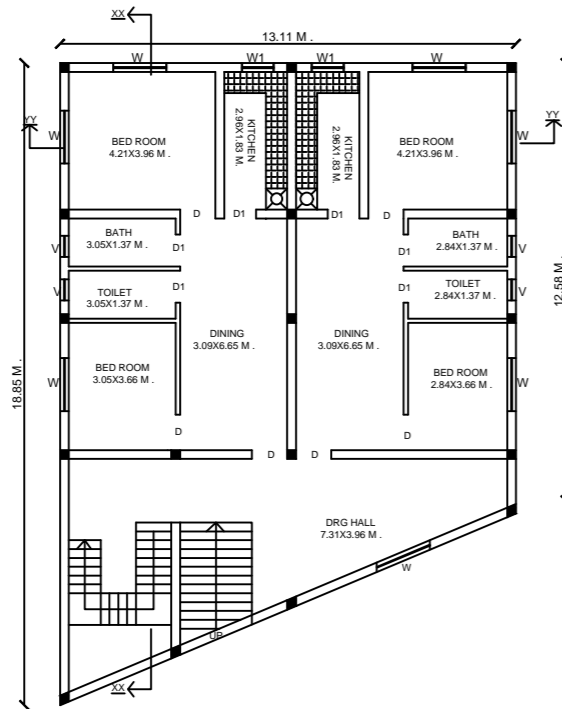

PROPOSED GROUND FLOOR PLAN

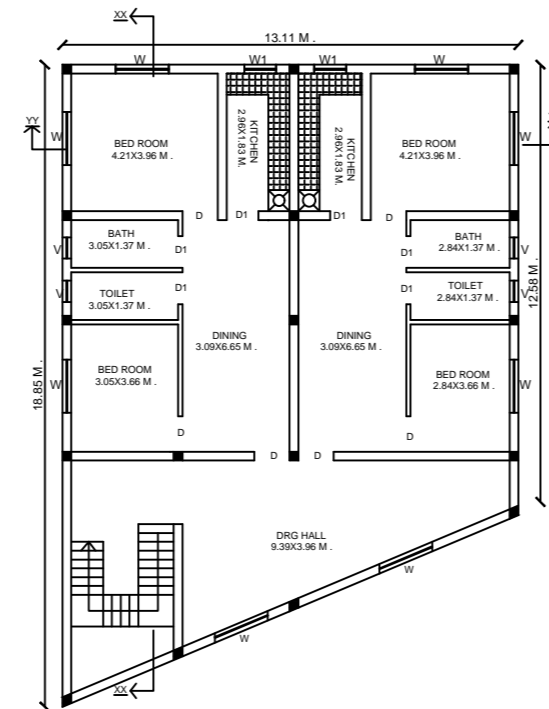

PROPOSED FIRST FLOOR PLAN

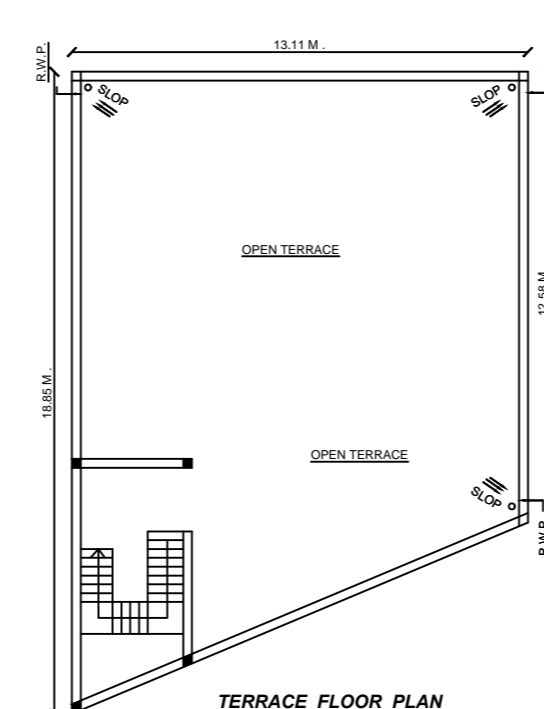

TERRACE FLOOR PLAN

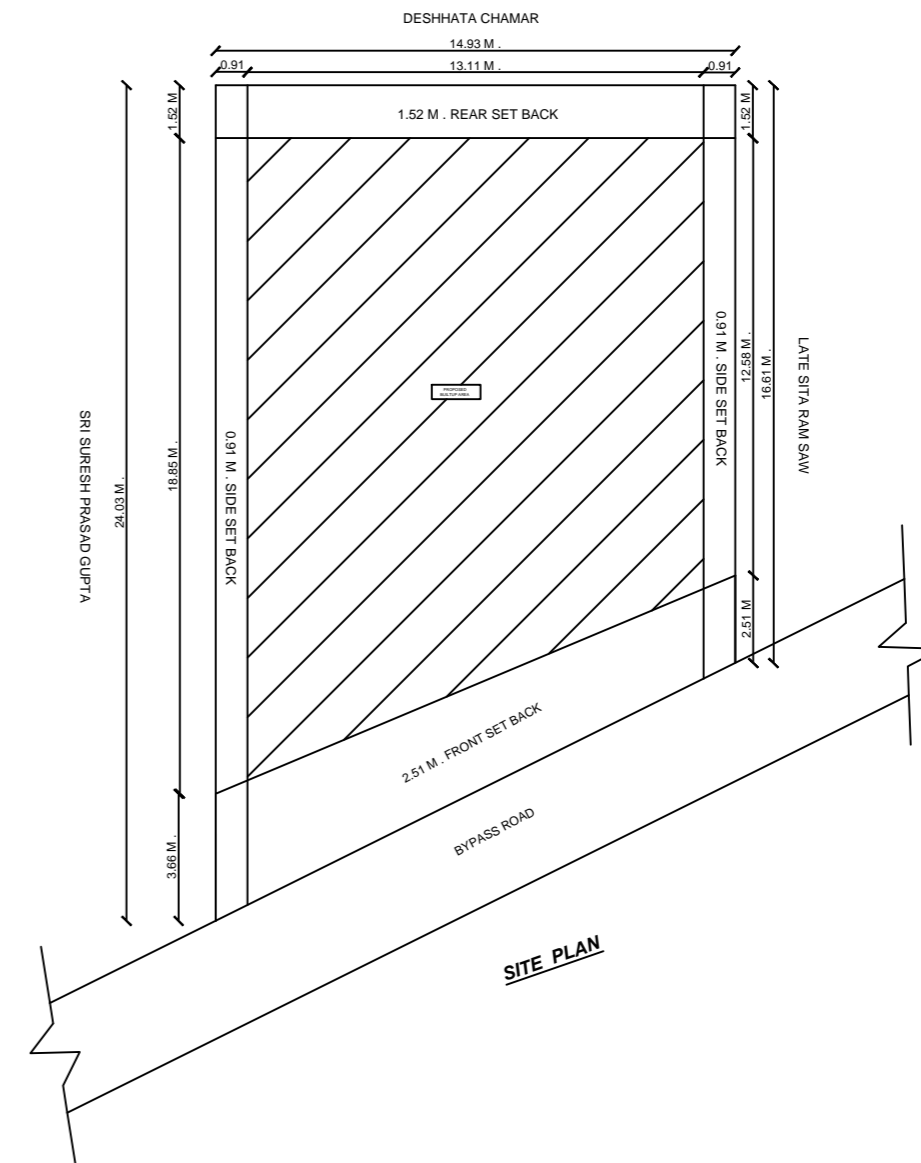

SITE PLAN

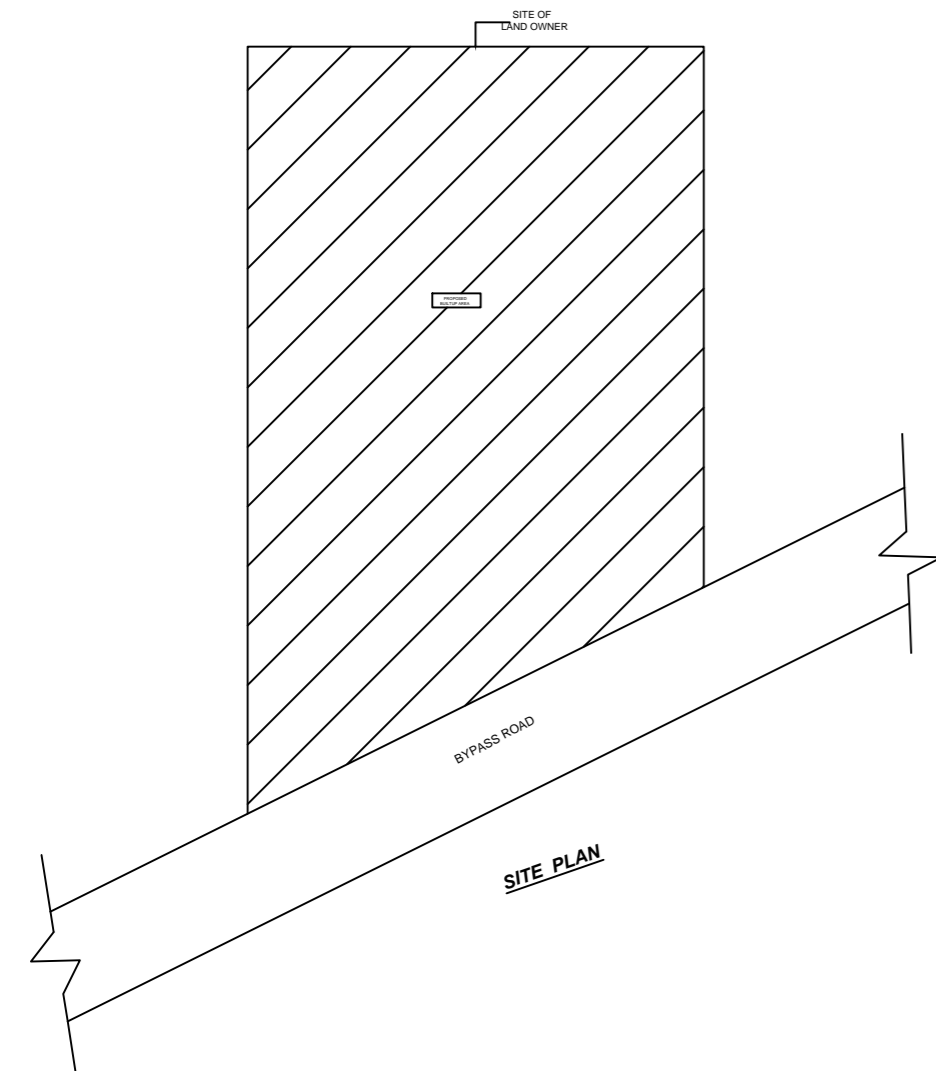

SITE PLAN

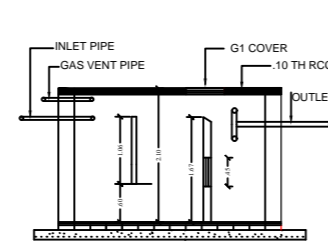

SECTION (N.T.S)

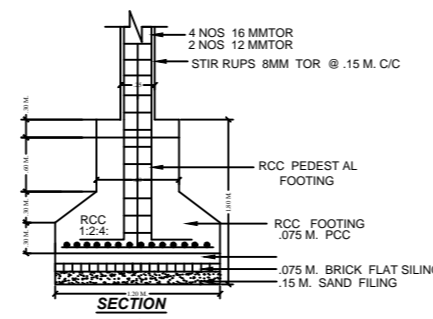

SECTION (N.T.S)

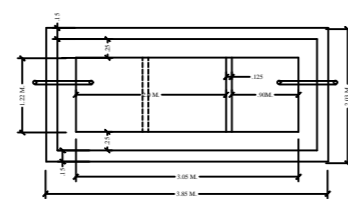

PLAN (N.T.S)

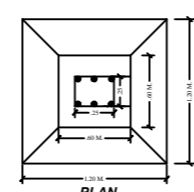

PLAN

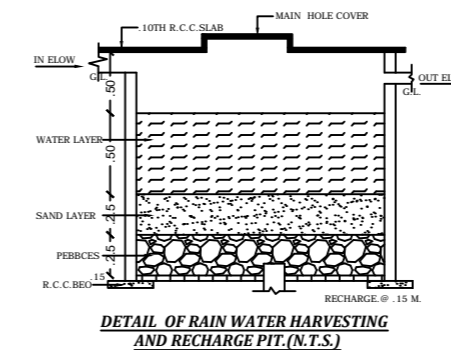
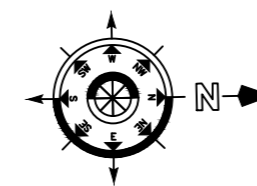

DETAIL OF RAIN WATER HARVESTING AND RECHARGE PIT (N.T.S)

SCHEDULE OF DS & WS		
TYPE	SIZE	REMARKS
D	1.06 M.X2.10 M.	F PANELED
D1	0.06 M.X2.10 M.	F PANELED
D2	0.75 M.X2.10 M.	F PANELED
W	1.50 M.X1.20 M.	F GLAZZED
W1	1.20 M.X1.20 M.	F GLAZZED
W2	0.91 M.X1.20 M.	F GLAZZED
C.GATE	2.10 M.X2.10 M.	IRON

SPECIFICATION	
1	DETAIL OF R.C.C. FOOTING COLUMN FON (1:6)
2	1ST CLASS BRICK WORK IN CEMENT PLASTER (1:6)
3	1.25X.15TH. R.C.C. LINTEL BAND OVER DOOR'S & WINDOW'S
4	10TH. LIME CON. TERR.OVER . 10TH. R.C.C. ROOF SLAB(M.25)
5	SAL WOOD FRAME & SJAM WOOD SHUTTER.
6	0.012TH. IN CEMENT PLASTER IN BOTH SIDE WACC (1:6)
7	MARBLE OR MOSAIC FLOORING OVER . 110TH. DRY RAMMED KHOA OVER B.F. SOILING . OVER LOCAL SAND FILLING .
8	2 CUAT OF WHITE & COLOUR WASH AS PER CHOICE .
9	17CM.WIDE & 30 CM. PUCCA DRAIN AROUND THE BUILDING .

TOTAL PLOT AREA	=	303.37	SQM.
NET PLOT AREA	=	303.37	SQM.
TOTAL OPEN LAND AREA	=	97.35	SQM.
BASMENT FLOOR AREA	=	206.02	SQM.
G. FLOOR BUILT UP AREA	=	206.02	SQM.
FIRST FLOOR B/A	=	206.02	SQM.
TOTAL B/A	=	618.06	SQM.
F.A.R.	=	2.0	
% OF COVRED AREA	=	67	%
BUILDING HEIGHT	=	6.0	M.

PROPOSED RESIDENTIAL BUILDING OF
 NAME- SMT. SHAIL GUPTA
 W/O. - SRI PRAMOD KUMAR GUPTA
 MAUZA - LATEHAR
 P.S. - LATEHAR
 P.S. NO. - 250
 WARD NO. -
 KHATA NO. - 123
 H. NO. -
 PLOT NO. - 462
 TOUZI NO. - 51
 DIST. - LATEHAR (JHARKHAND)

MAP APPROVED BY

SIGNATURE OF APPLICANT

SIGNATURE OF ENGINEER