

(Scale - 1:200)

FAR & Tenement Details (Table 4c-1)

Building	No. of Same Bldg	Gross Built Up Area (Sq.mt.)	Deductions From Gross BUA/Area in Sq.mt.)		Total Built Up Area (Sq.mt.)	Deductions (Area in Sq.mt.)		Proposed FAR Area (Sq.mt.)	Total FAR Area (Sq.mt.)	Total Consumed Additional FAR Area (Sq.mt.)	Tnmt (No.)
			Cutout			Balcony	Parking				
ABC (123)	1	334.36	19.02		315.34	9.41	12.29	293.64	293.64	293.64	01
Grand Total	1	334.36	19.02		315.34	9.41	12.29	293.64	293.64	293.64	01

Proposal Basic Information

Proposal File No.	LNPC/BP/0021/W02/2024
Owner Name	MUNDRIKA SINGH RADHIKA SING
Khata No	14
Plot No	68
Village Name	Mako
Use	Residential
SubUse	Bungalow/ Dwelling / Non Apartment

Building USE/SUBUSE Details

Building Name	Building Use	Building SubUse	Building Structure	Floor Name	Floor Use	Floor SubUse	FAR Name	FAR Use	FAR SubUse
ABC (123)	Residential	Bungalow/ Dwelling / Non Apartment	Non-Highrise	GROUND FLOOR PLAN	Residential	Bungalow/ Dwelling / Non Apartment	Residential FAR	Residential	Bungalow/ Dwelling / Non Apartment
				FIRST FLOOR PLAN	Residential	Bungalow/ Dwelling / Non Apartment	Residential FAR	Residential	Bungalow/ Dwelling / Non Apartment
				TERRACE FLOOR PLAN	Residential	Bungalow/ Dwelling / Non Apartment	-	-	-

AREA STATEMENT LATEHAR NAGAR PANCHAYAT		VERSION NO: 1.0.71
		VERSION DATE: 16/10/2020
PROJECT DETAIL:		
Region: JHARKHAND URBAN LOCAL BODIES	Plot Use: Residential	
District: LATEHAR	Plot SubUse: Bungalow/ Dwelling / Non Apartment	
Authority: LATEHAR NAGAR PANCHAYAT	PlotNearby/ReligiousStructure: NA	
Inward_No: LNPC/BP/0021/W02/2024	Plot/SubPlot No: 68	
Application Type: General Proposal	North: Plot No. - PRADEEP AGRWAL	
Project Type: Building Permission	South: Plot No. - RAMKHELWAN MANJHI	
Nature of Development: New	East: Road Width - 3.66	
Location of Development Area: New Area	West: Plot No. - MUNNI SHING	
AREA DETAILS:		
AREA OF PLOT (Minimum)	(A)	SQ.MT. 1021.61
Deduction for NetPlot Area		
Surrender Free of Cost		39.12
Total		39.12
NET AREA OF PLOT(Gross Plot Area - Deduction from Gross Plot area)	(A-Deductions)	982.49
Deduction for Balance Plot Area(from Gross Plot Area)		
Surrender Free of Cost		39.12
Common Plot		98.68
Total		137.80
BALANCE AREA OF PLOT(Net Plot Area - Recreational/Amenity space)	(A-Deductions)	883.81
PLOT AREA FOR COVERAGE(Net Plot Area)	(A-Deductions)	982.49
Plot Area for FAR (Net Plot Area + RoadWidening Area)	(A-Deductions)	1021.61
COVERAGE CHECK		
Permissible Coverage area (60.00 %)		589.49
Proposed Coverage Area (17.49 %)		171.83
Total Prop. Coverage Area (17.49 %)		171.83
Balance coverage area (42.51 %)		417.66
FAR CHECK		
Perm. FAR Area (1.500)		1532.42
Total Perm. FAR area		1532.42
Residential FAR		293.64
Proposed FAR Area		293.64
Total Proposed FAR Area		293.64
Consumed FAR (Factor)		0.29
Balance FAR Area		1238.78
BUILT UP AREA CHECK		
Total Proposed BuiltUp Area		315.34
ARCHITECT (Regd)	TASLIM ANSARI	
ENGINEER (Regd)		
SUPERVISOR (Regd)		
OWNER (Regd)	MUNDRIKA SINGH RADHIKA SING	
DEVELOPMENT AUTHORITY		LOCAL BODY

COLOR INDEX	
PLOT BOUNDARY	Black
ABUTTING ROAD	Green
PROPOSED CONSTRUCTION	Red
COMMON PLOT	Yellow
ROAD WIDENING AREA	Blue
EXISTING (To be retained)	Light Blue
EXISTING (To be demolished)	Light Yellow

Buildingwise Floor FAR Details

Floor Name	Building Name		Total	
	Proposed Built Up Area (Sq.mt.)	Proposed FAR Area (Sq.mt.)	Total Proposed Built Up Area (Sq.mt.)	Total FAR Area (Sq.mt.)
Ground Floor	171.83	159.54	171.83	159.54
First Floor	143.51	134.10	143.51	134.10
Terrace Floor	0.00	0.00	0.00	0.00
Total :	315.34	293.64	315.34	293.64

LTP NAME AND SIGNATURE	STRUCTURAL ENG'S NAME AND SIGNATURE	BUILDER NAME AND SIGNATURE	DIGITAL SIGNATURE
TASLIM ANSARI LNPC/ENG/0018/2022			

Proposal Basic Information	
Proposal File No.	LNPC/BP/0021/W02/2024
Owner Name	MUNDRIKA SINGH RADHIKA SING
Khata No	14
Plot No	68
Village Name	Mako
Use	Residential
SubUse	Bungalow/ Dwelling / Non Apartment

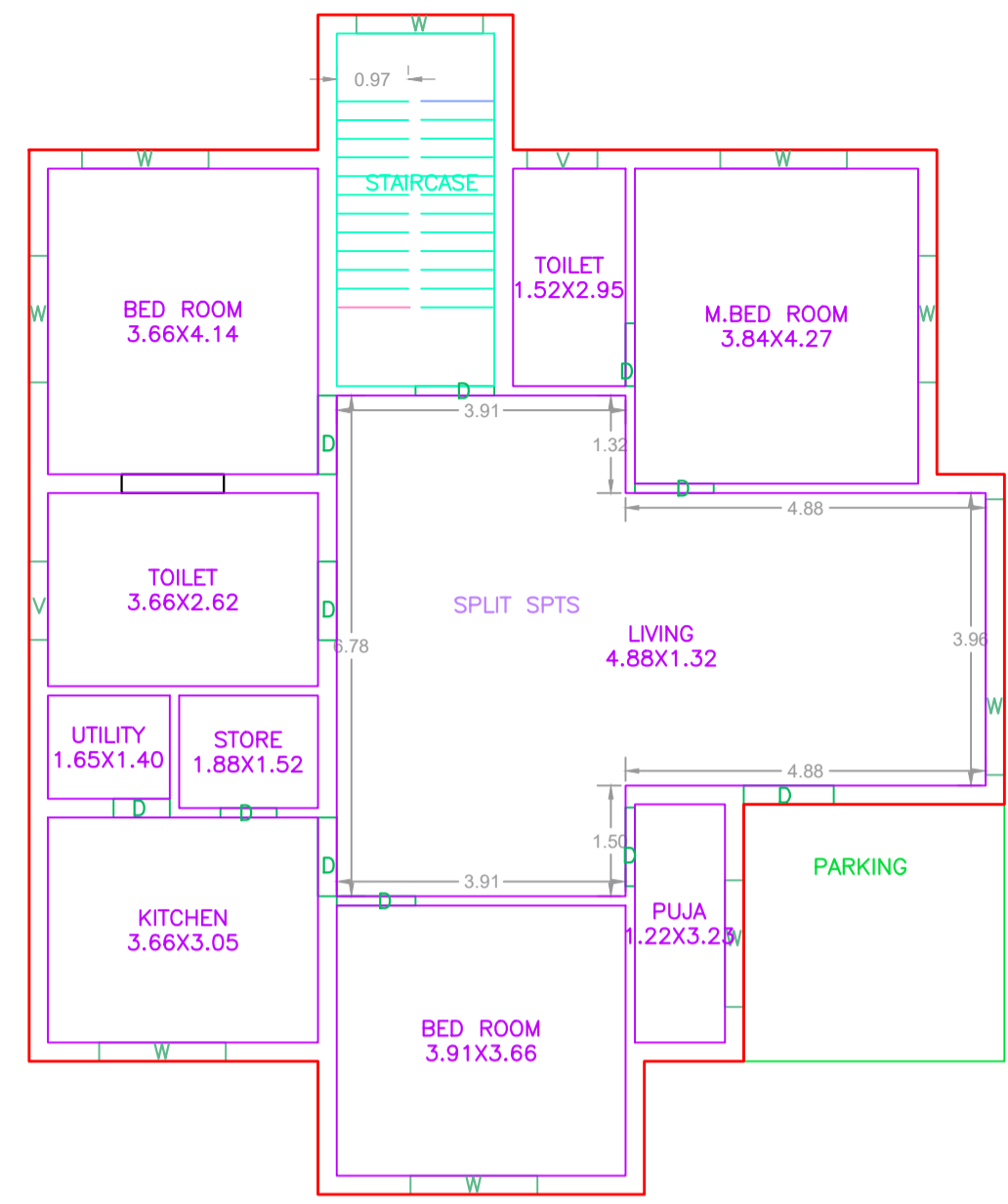

GROUND FLOOR PLAN (Proposed) (SCALE 1:100)

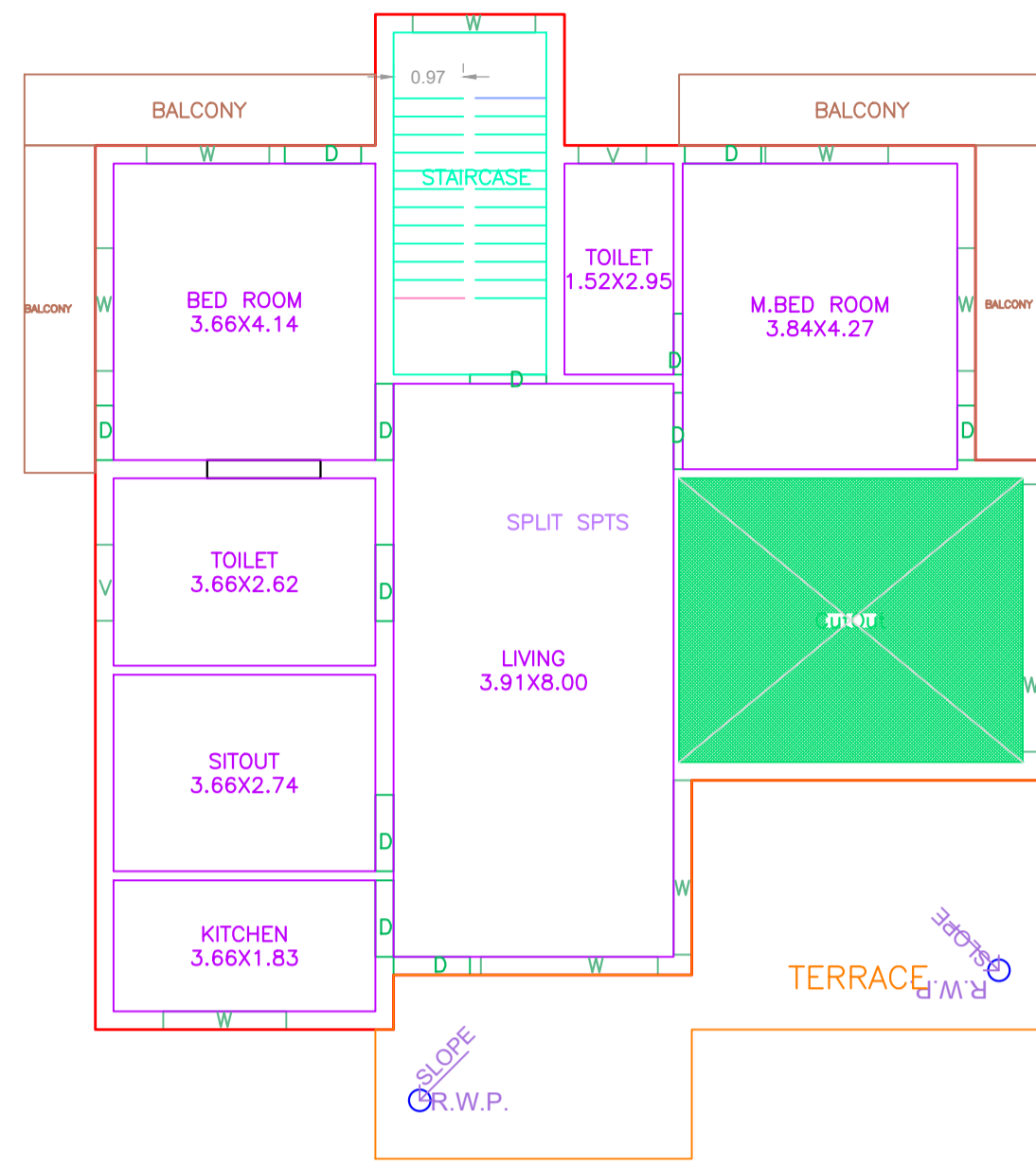

FIRST FLOOR PLAN (Proposed) (SCALE 1:100)

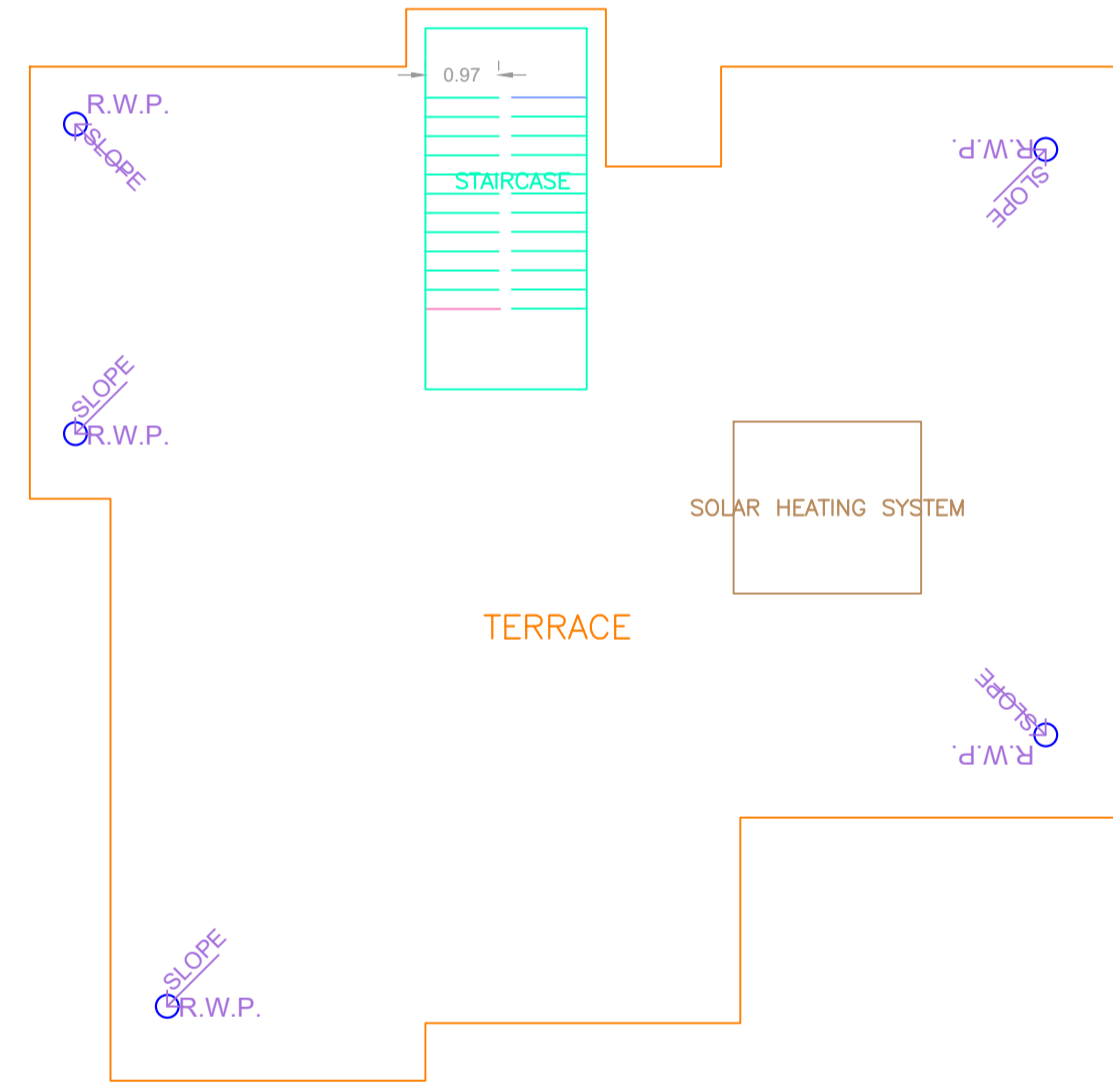

TERRACE FLOOR PLAN (SCALE 1:100)

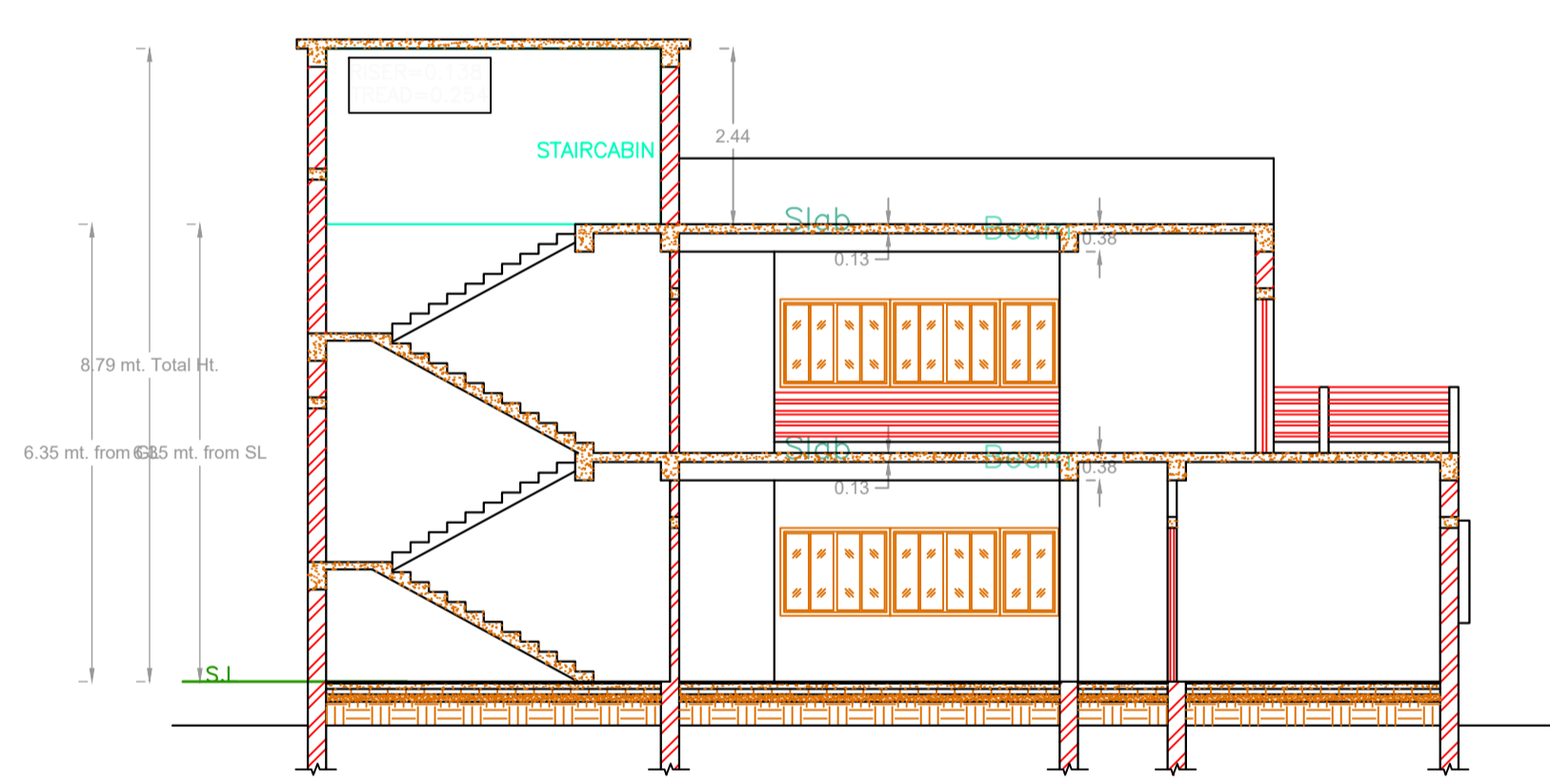

SECTION Y-Y' (SCALE- 1:100)

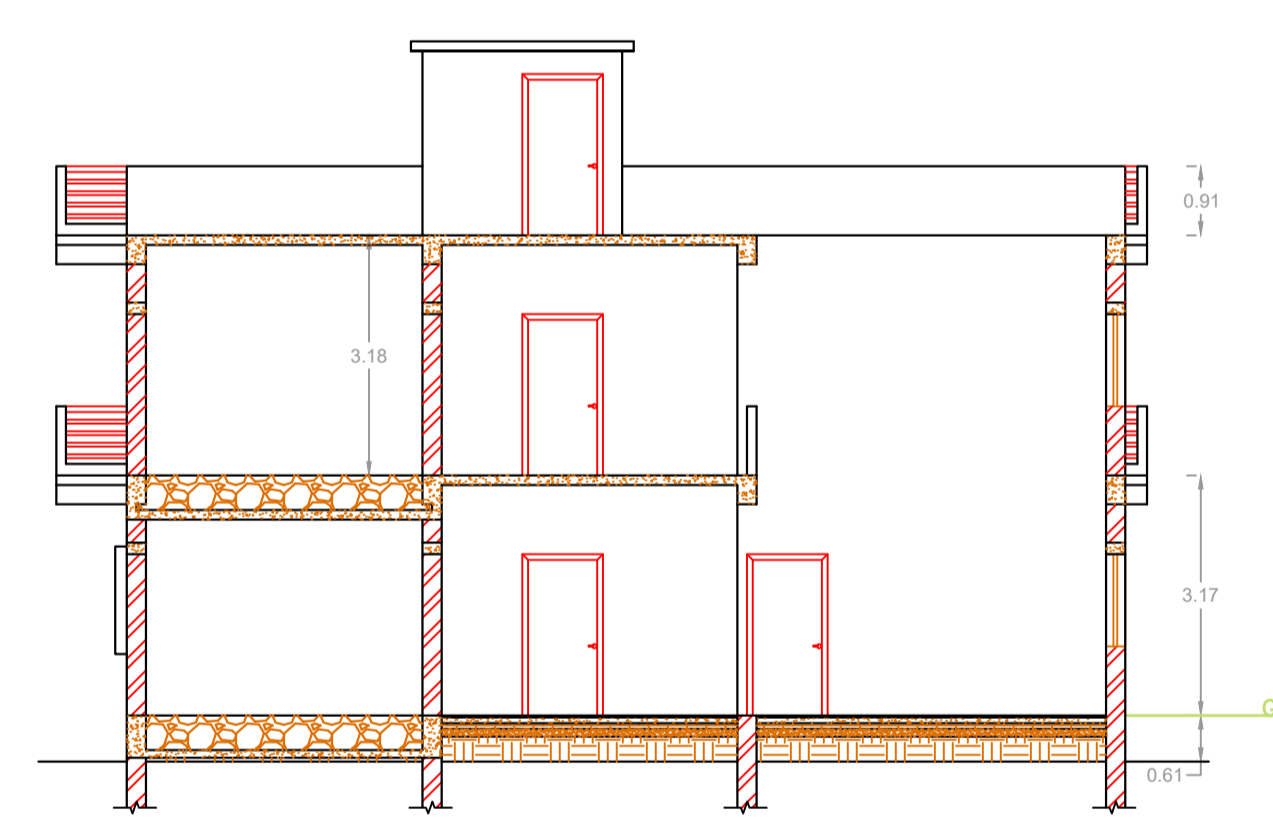

SECTION X-X' (SCALE- 1:100)

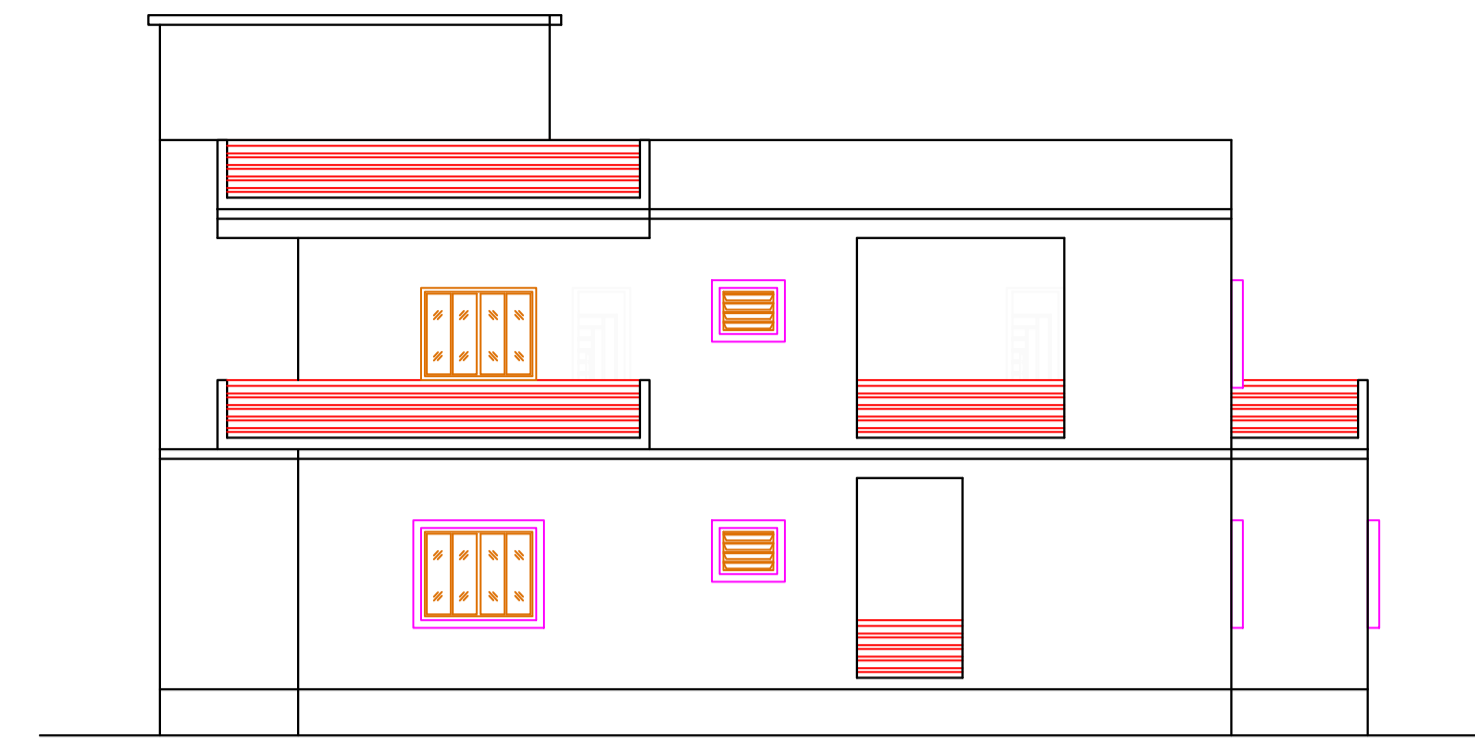

SIDE ELEVATION (SCALE- 1:100)

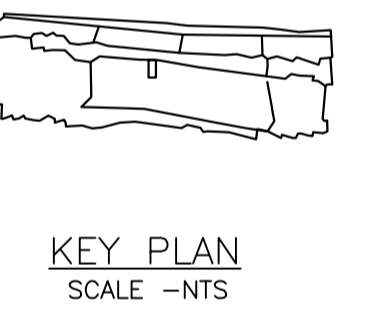
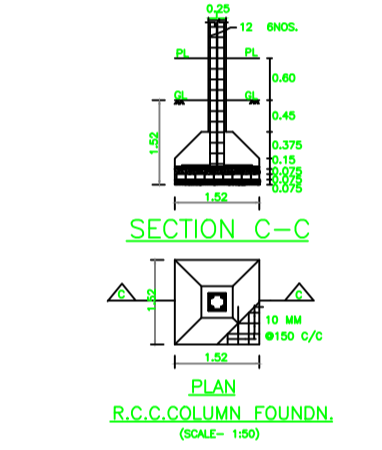
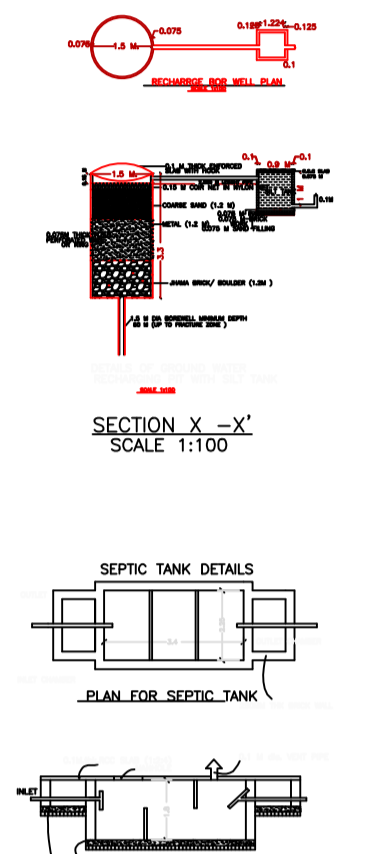

Building :ABC (123)

Floor Name	Gross Builtup Area	Deductions From Gross BUA/Area in Sq.mt.)	Total Built Up Area (Sq.mt.)	Deductions (Area in Sq.mt.)		Proposed FAR Area (Sq.mt.)	Total FAR Area (Sq.mt.)	Total Consumed Additional FAR Area (Sq.mt.)	Trmt (No.)
				Balcony	Parking				
Ground Floor	171.83	0.00	171.83	0.00	12.29	159.54	159.54	159.54	01
First Floor	162.53	19.02	143.51	9.41	0.00	134.10	134.10	134.10	00
Terrace Floor	0.00	0.00	0.00	0.00	0.00	0.00	0.00	0.00	00
Total :	334.36	19.02	315.34	9.41	12.29	293.64	293.64	293.64	01
Total Number of Same Buildings :	1								
Total :	334.36	19.02	315.34	9.41	12.29	293.64	293.64	293.64	01

SCHEDULE OF DOOR:

BUILDING NAME	NAME	LENGTH	HEIGHT	NOS
ABC (123)	D	0.76	2.10	04
ABC (123)	D	0.85	2.10	02
ABC (123)	D	1.07	2.10	16
ABC (123)	D	1.22	2.10	01

SCHEDULE OF WINDOW/VENTILATION:

BUILDING NAME	NAME	LENGTH	HEIGHT	NOS
ABC (123)	V	0.95	0.61	02
ABC (123)	V	1.06	0.61	02
ABC (123)	W	1.72	1.20	14
ABC (123)	W	2.43	1.20	01
ABC (123)	W	2.47	1.20	01
ABC (123)	W	3.73	1.20	01

Balcony Calculations Table

FLOOR	SIZE	AREA	TOTAL AREA
FIRST FLOOR PLAN	0.99 X 4.90 X 1 X 1	4.86	18.82
	0.99 X 4.57 X 1 X 1	4.53	
	0.99 X 5.13 X 1 X 1	5.08	
	0.99 X 4.40 X 1 X 1	4.35	
Total	-	-	18.82

UnitBUA Table for Building :ABC (123)

FLOOR	Name	UnitBUA Type	UnitBUA Area	Carpet Area	No. of Rooms	No. of Tenement
GROUND FLOOR PLAN	SPLIT SPTS	FLAT	303.05	283.48	10	1
FIRST FLOOR PLAN	SPLIT SPTS	FLAT	0.00	0.00	7	0
Total:	-	-	303.05	283.48	17	1

LTP NAME AND SIGNATURE	STRUCTURAL ENG'S NAME AND SIGNATURE	BUILDER NAME AND SIGNATURE	DIGITAL SIGNATURE
TASLIM ANSARI LNPC/ENG/0018/2022			

Proposal Basic Information

Proposal File No.	LNPC/BP/0021/W02/2024
Owner Name	MUNDRIKA SINGH RADHIKA SING
Khata No	14
Plot No	68
Village Name	Mako
Use	Residential
SubUse	Bungalow/ Dwelling / Non Apartment

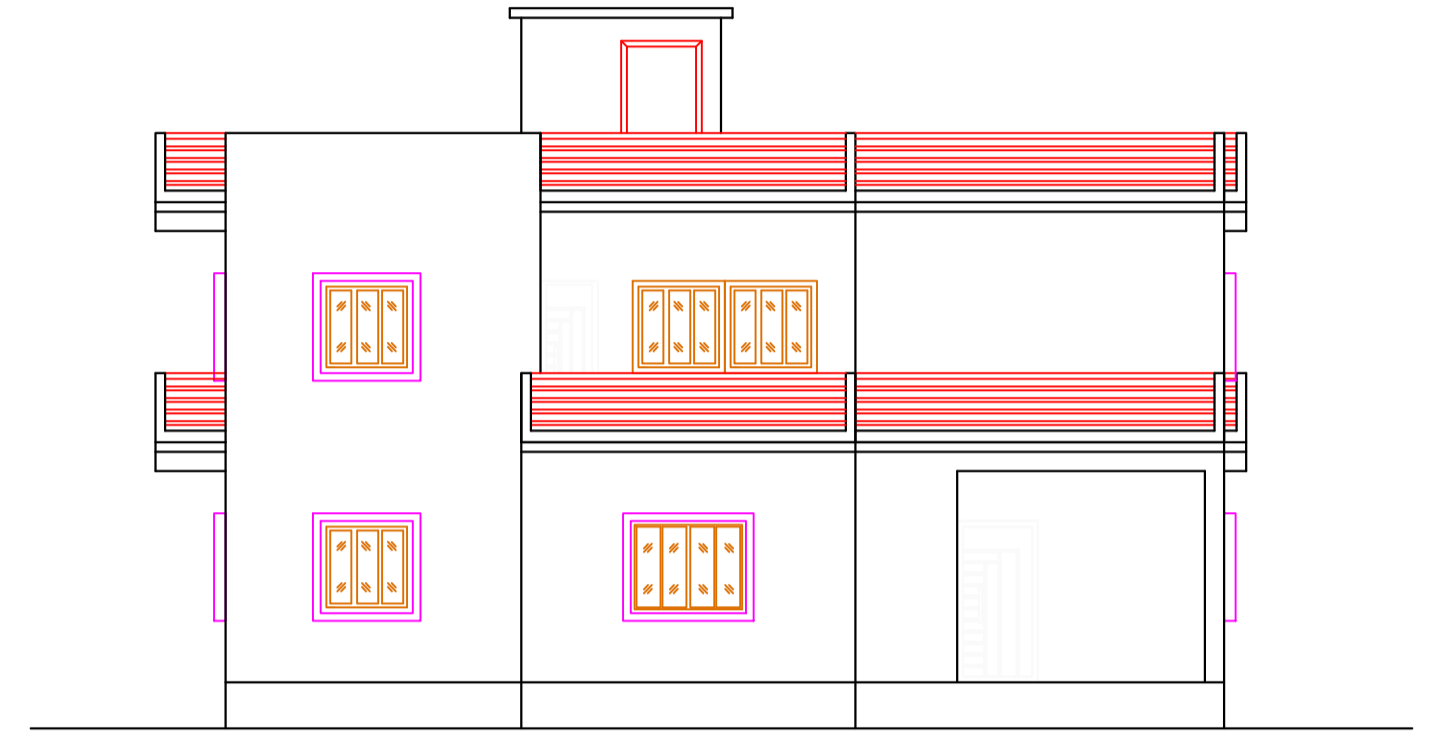

FRONT ELEVATION
(SCALE= 1:100)

LTP NAME AND SIGNATURE	STRUCTURAL ENG'S NAME AND SIGNATURE	BUILDER NAME AND SIGNATURE	DIGITAL SIGNATURE
TASLIM ANSARI LNPC/ENG/0018/2022			