

Proposal Basic Information

Proposal File No.	MJNPC/BP/0004/W08/2022
Owner Name	NISHA SAO
Khata No	169/ka/1
Plot No	1072/G/1/A
Village Name	Mihijam
Use	Residential
SubUse	Bungalow/ Dwelling / Non Apartment

AREA STATEMENT MIHIJAM NAGAR PANCHAYAT	VERSION NO.: 1.0.62	VERSION DATE: 16/10/2020
PROJECT DETAIL:		
Region: JHARKHAND URBAN LOCAL BODIES	Plot Use: Residential	
District: JAMTARA	Plot SubUse: Bungalow/ Dwelling / Non Apartment	
Authority: MIHIJAM NAGAR PANCHAYAT	Plot/Nearby/Religious/Structure: NA	
Invst. No: MJNPC/BP/0004/W08/2022	Plot/SubPlot No: 1072/G/1/A	
Application Type: General Proposal	North: -	
Project Type: Building Permission	South: -	
Nature of Development: New	East: -	
Location of Development Area: Old Area	West: -	
AREA DETAILS:		
AREA OF PLOT (Minimum)	(A)	328.77 SQ.MT.
NET AREA OF PLOT(Gross Plot Area - Deduction from Gross Plot area)	(A-Deductions)	328.77
Deduction for Balance Plot Area(from Gross Plot Area)		
Common Plot		30.10
Total		30.10
BALANCE AREA OF PLOT(Net Plot Area - Recreational/Amenity space)	(A-Deductions)	298.67
PLOT AREA FOR COVERAGE(Net Plot Area)	(A-Deductions)	328.77
Plot Area for FAR (Net Plot Area + RoadWidening Area)	(A-Deductions)	328.77
COVERAGE CHECK		
Permissible Coverage area ( 60.00 % )		197.26
Proposed Coverage Area ( 52.15 % )		171.45
Total Prop. Coverage Area ( 52.15 % )		171.45
Balance coverage area ( 7.85 % )		25.81
FAR CHECK		
Perm. FAR Area ( 2.00 )		657.54
Total Perm. FAR area		657.54
Residential FAR		328.76
Proposed FAR Area		328.76
Total Proposed FAR Area		328.76
Consumed FAR (Factor)		1.00
Balance FAR Area		328.78
BUILT UP AREA CHECK		
Total Proposed BuiltUp Area		342.90
ARCHITECT (Regd)	irshad hussain khan	
ENGINEER (Regd)		
SUPERVISOR (Regd)		
OWNER (Regd)	NISHA SAO	
DEVELOPMENT AUTHORITY LOCAL BODY		

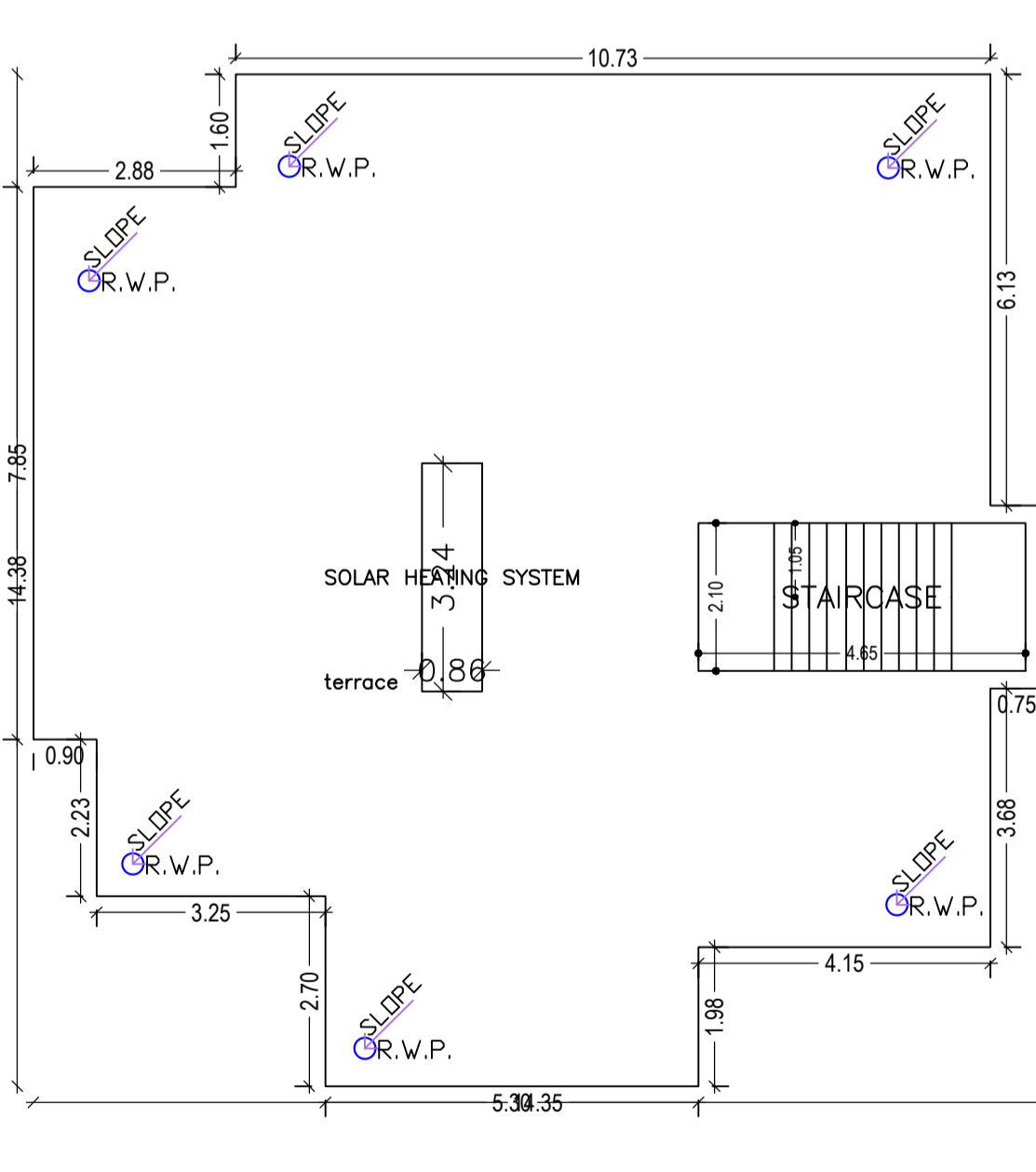
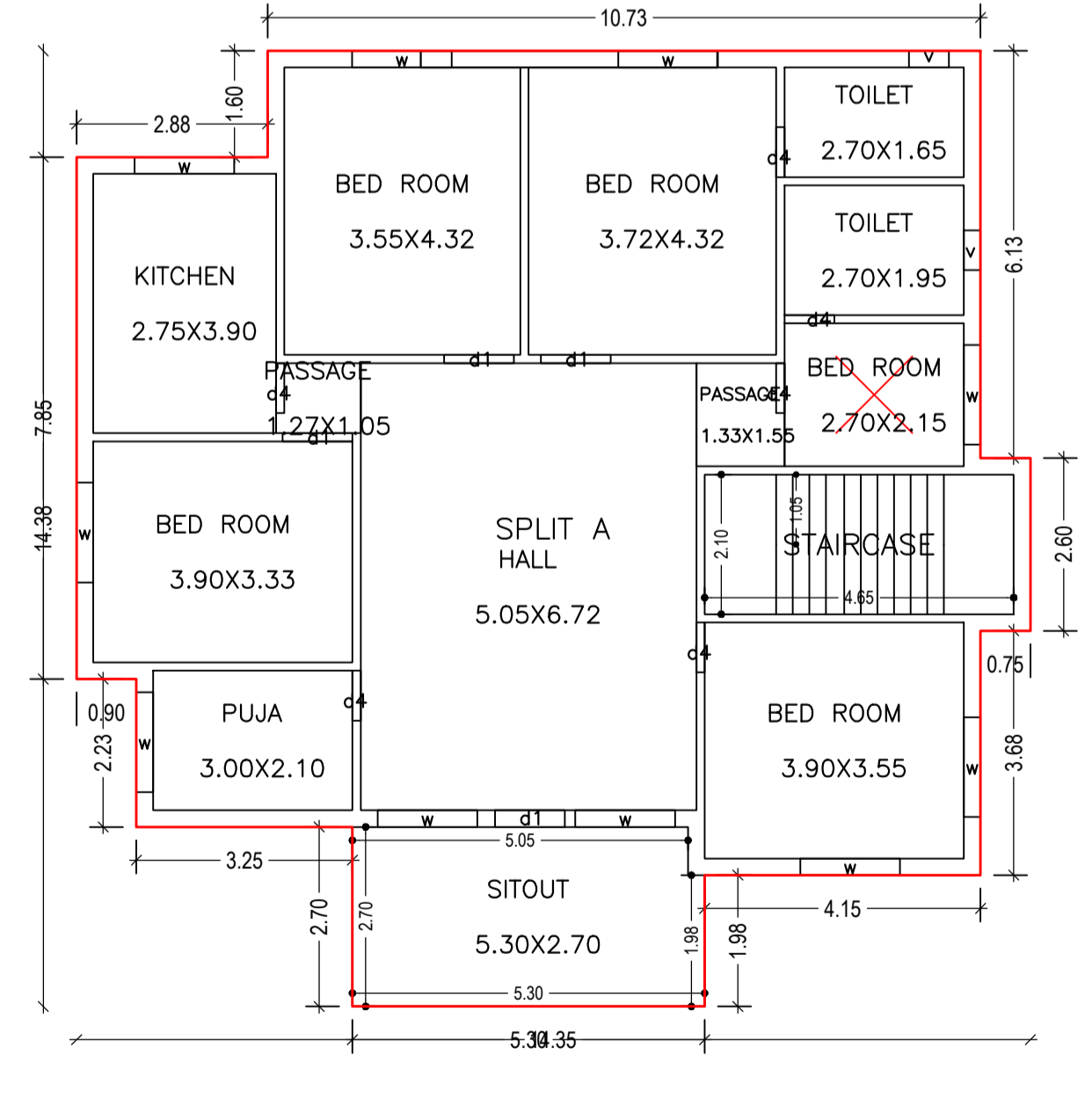
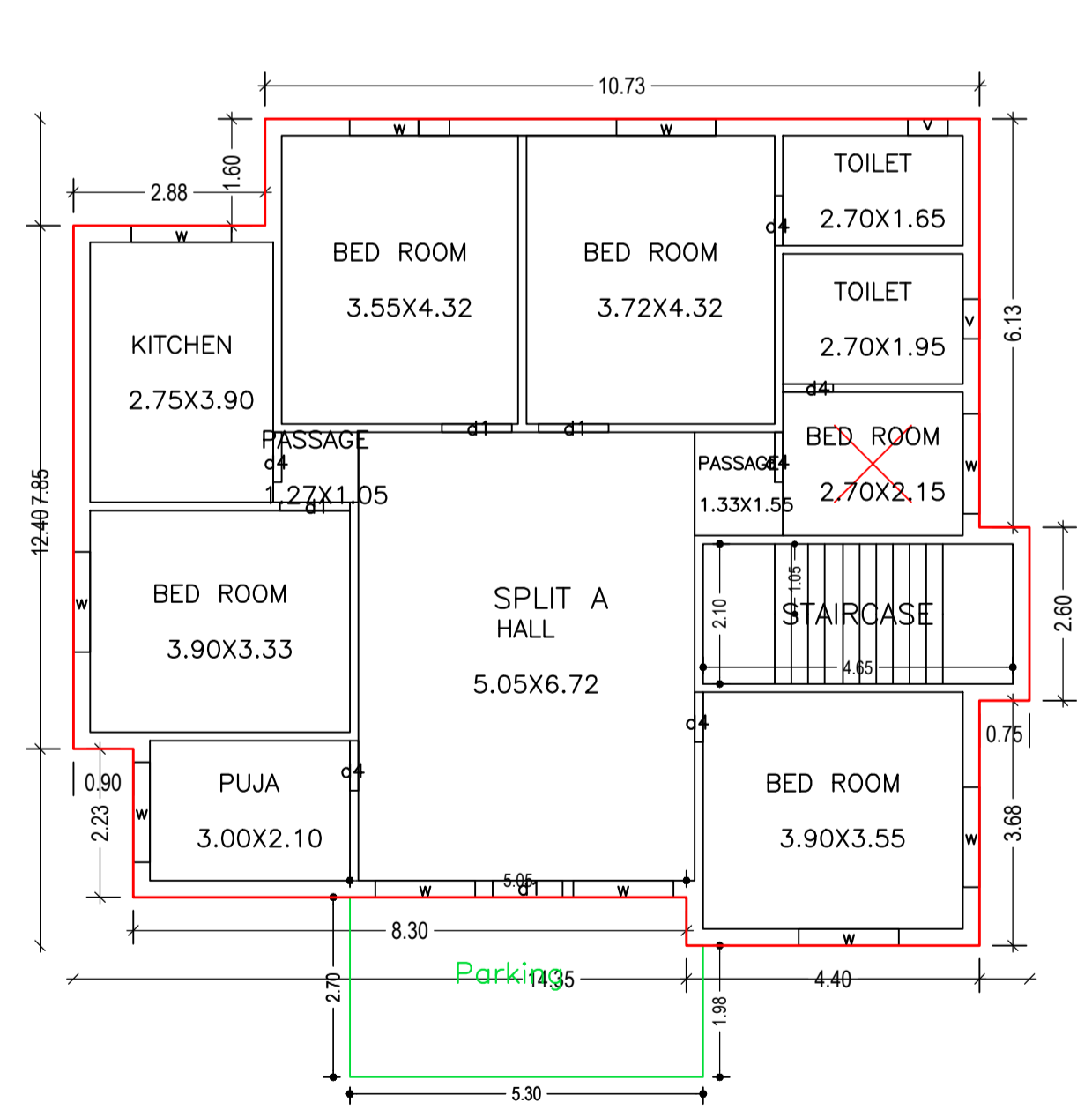
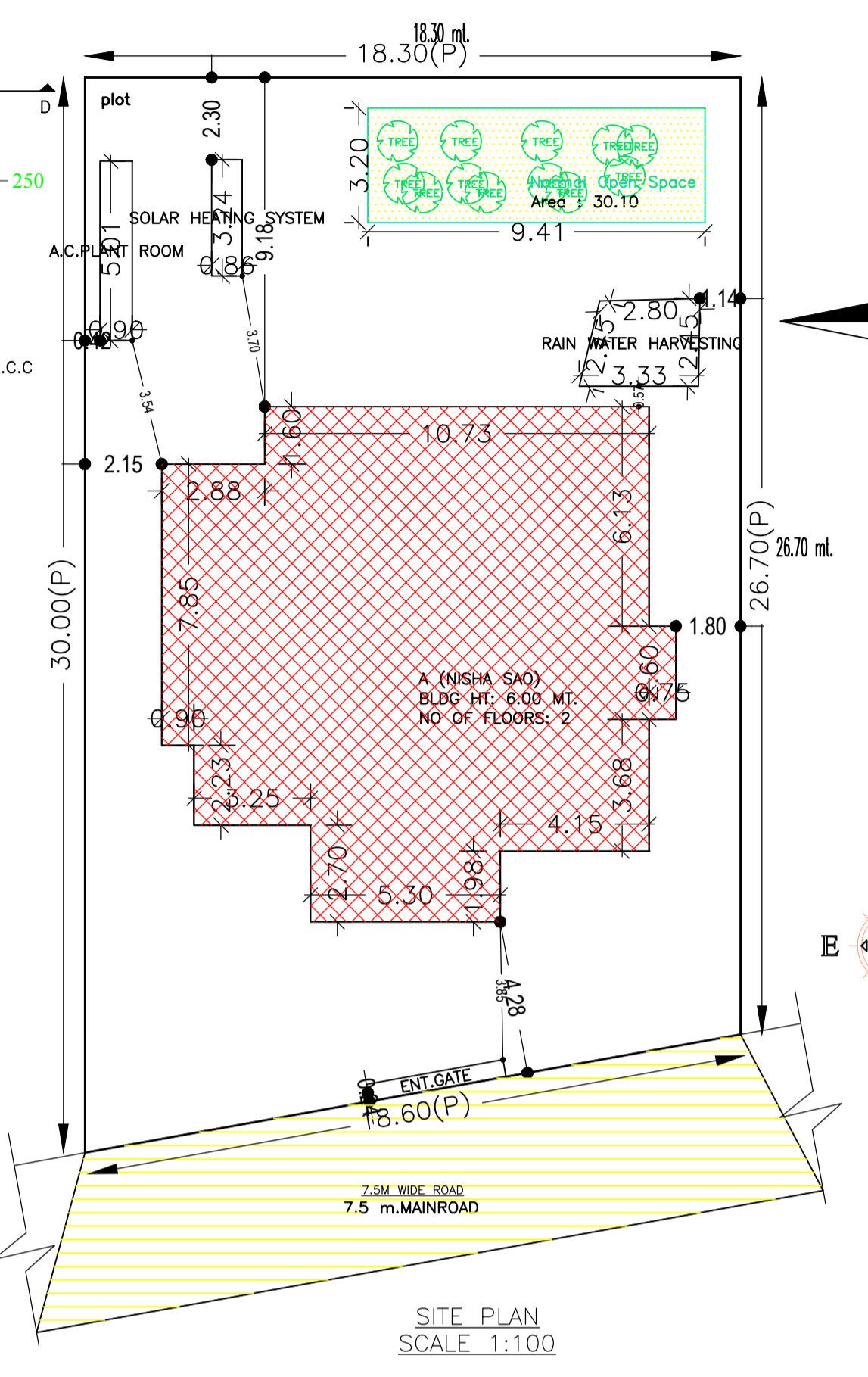
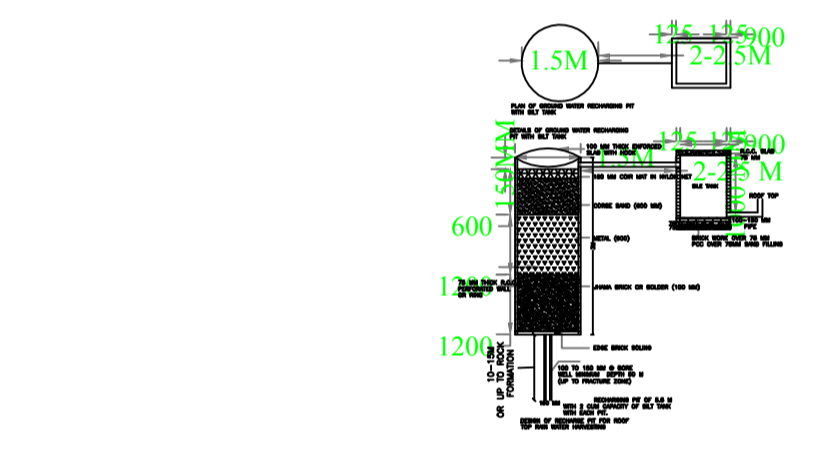
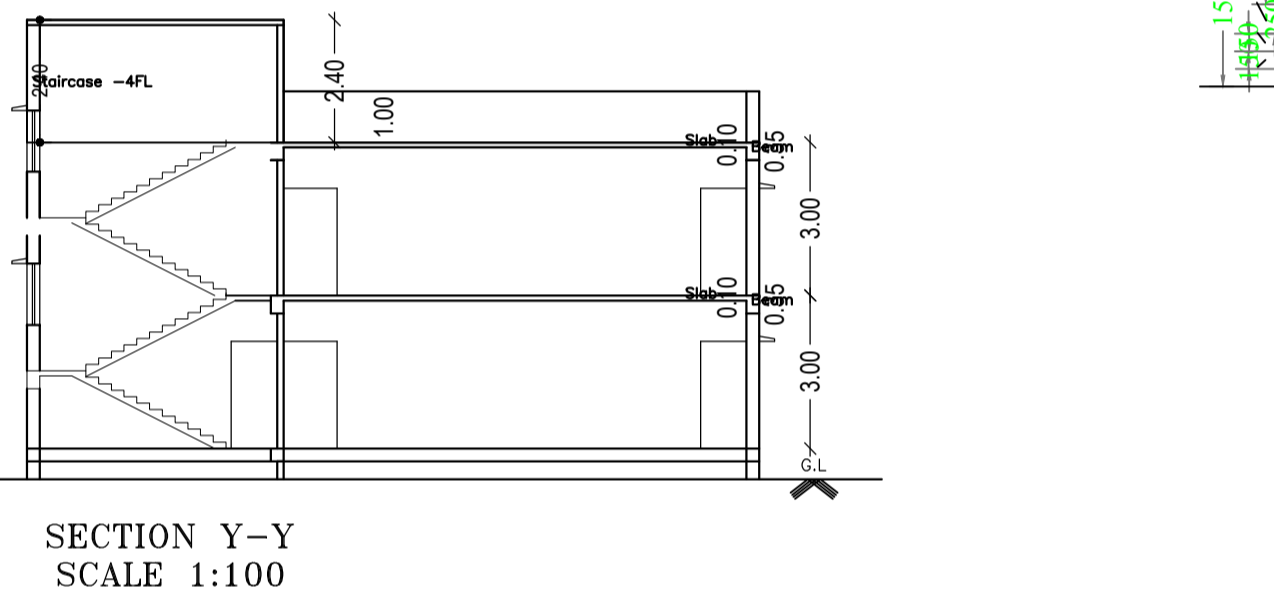
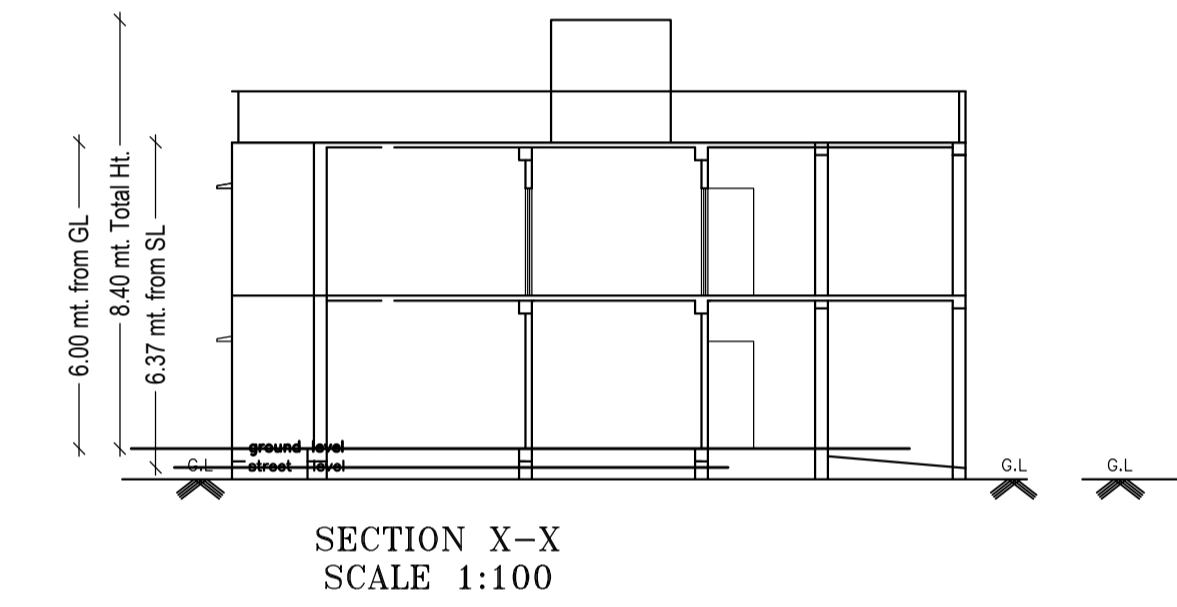
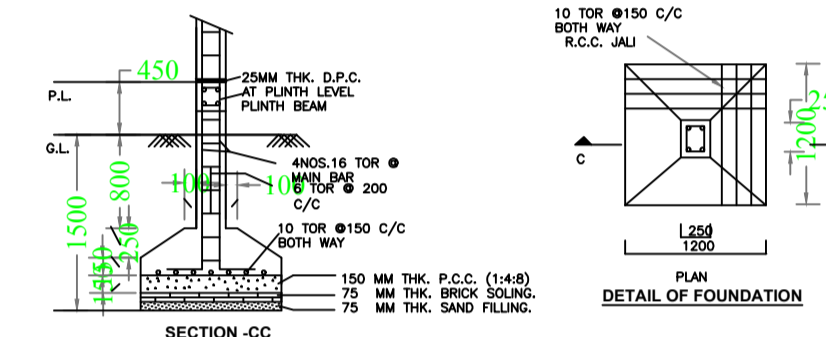
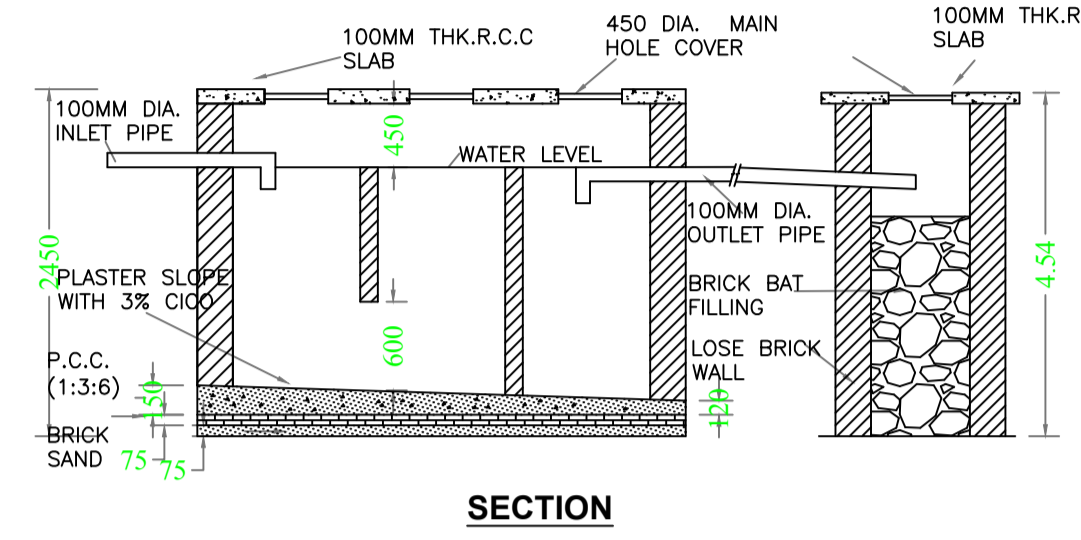
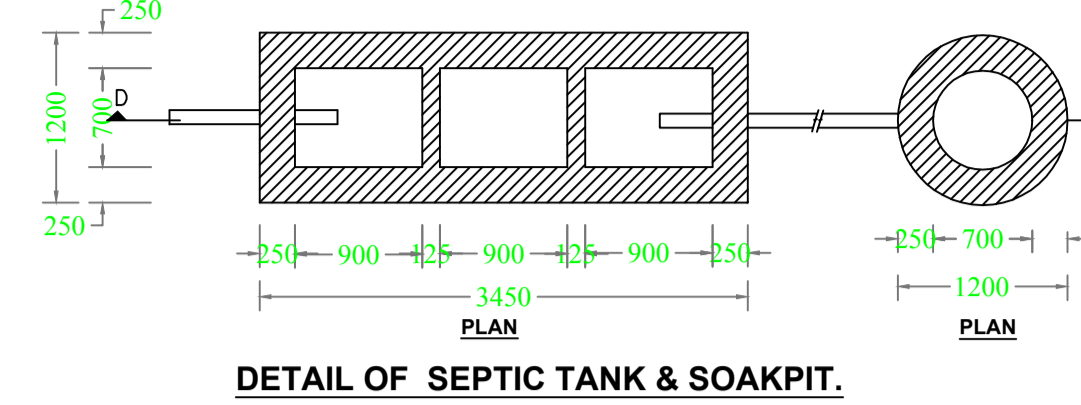
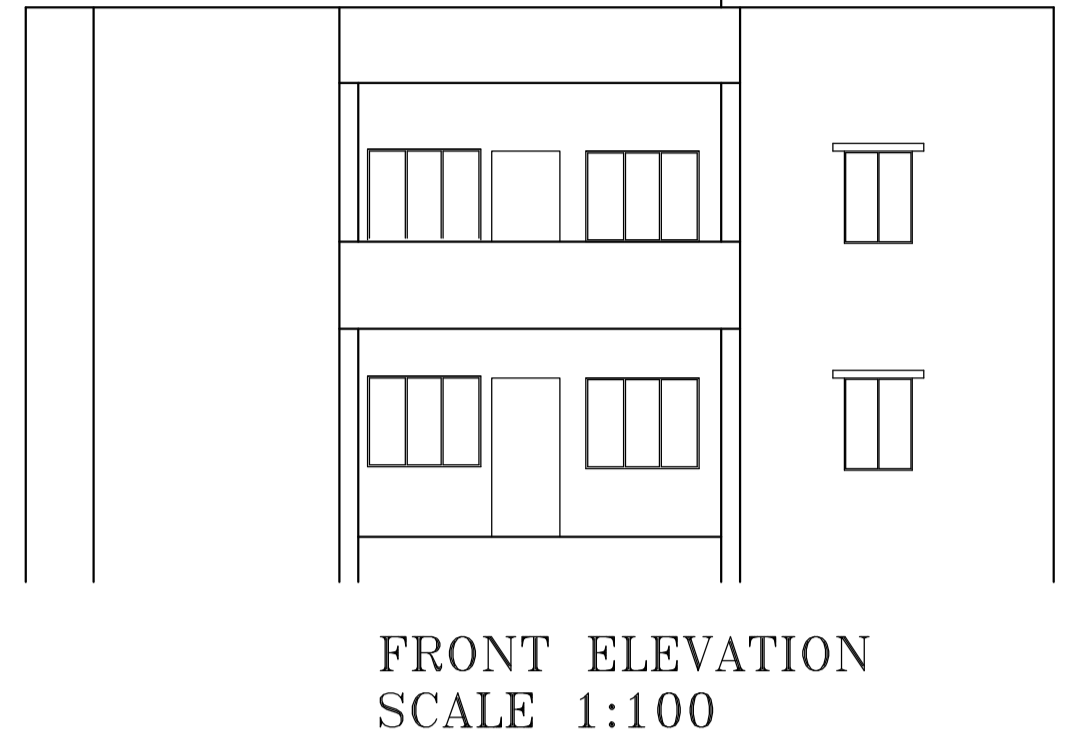
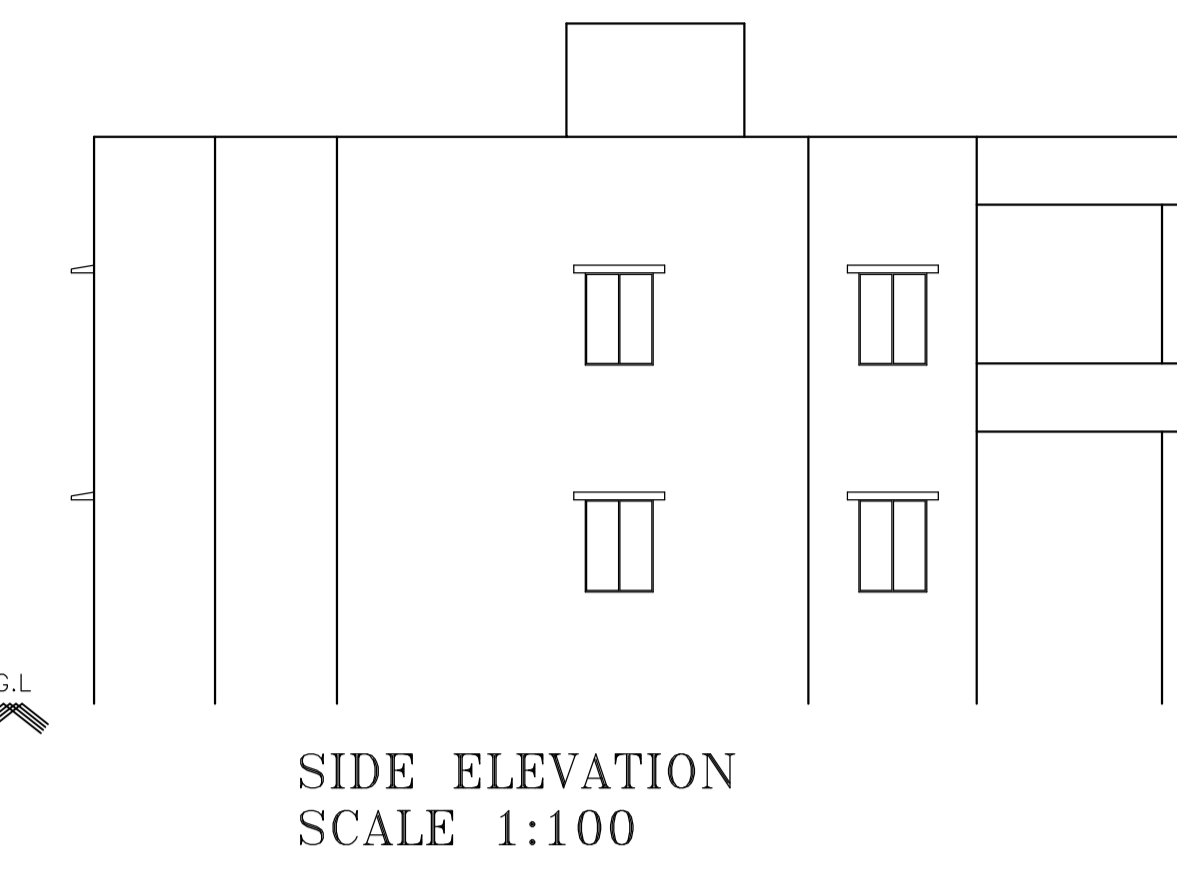

UnitBUA Table for Building :A (NISHA SAO)

FLOOR	Name	UnitBUA Type	UnitBUA Area	Carpet Area	No. of Rooms	No. of Tenement
GROUND FLOOR PLAN	SPLIT A	FLAT	328.76	328.53	12	1
FIRST FLOOR PLAN	SPLIT A	FLAT	0.00	0.00	13	0
Total:	-	-	328.76	328.53	25	1

SCHEDULE OF DOOR:

BUILDING NAME	NAME	LENGTH	HEIGHT	NOS
A (NISHA SAO)	d4	0.75	2.10	12
A (NISHA SAO)	d1	1.05	2.10	08

SCHEDULE OF WINDOW/VENTILATION:

BUILDING NAME	NAME	LENGTH	HEIGHT	NOS
A (NISHA SAO)	v	0.60	0.60	04
A (NISHA SAO)	w	1.50	1.20	20

Building :A (NISHA SAO)

Floor Name	Total Built Up Area (Sq.mt.)	Deductions (Area in Sq.mt.)	Proposed FAR Area (Sq.mt.)	Total FAR Area (Sq.mt.)	Total Consumed Additional FAR Area (Sq.mt.)	Trmt (No.)
Ground Floor	171.45	14.13	157.32	157.32	157.32	01
First Floor	171.45	0.00	171.45	171.45	171.45	00
Terrace Floor	0.00	0.00	0.00	0.00	0.00	00
Total:	342.90	14.13	328.77	328.77	328.77	01

Buildingwise Floor FAR Details

Floor Name	Building Name A (NISHA SAO)		Total	
	Proposed Built Up Area (Sq.mt.)	Proposed FAR Area (Sq.mt.)	Total Proposed Built Up Area (Sq.mt.)	Total FAR Area (Sq.mt.)
Ground Floor	171.45	157.32	171.45	157.32
First Floor	171.45	171.45	171.45	171.45
Terrace Floor	0.00	0.00	0.00	0.00
Total:	342.90	328.77	342.90	328.77

FAR & Tenement Details (Table 4c-1)

Building	No. of Same Bldg	Total Built Up Area (Sq.mt.)	Deductions (Area in Sq.mt.)	Proposed FAR Area (Sq.mt.)	Total FAR Area (Sq.mt.)	Total Consumed Additional FAR Area (Sq.mt.)	Trmt (No.)
A (NISHA SAO)	1	342.90	14.13	328.77	328.77	328.77	01
Grand Total:	1	342.90	14.13	328.77	328.77	328.77	01

Building USE/SUBUSE Details

Building Name	Building Use	Building SubUse	Building Structure
A (NISHA SAO)	Residential	Bungalow/ Dwelling / Non Apartment	Non-Highrise

COLOR INDEX

PLOT BOUNDARY	Black
ABUTTING ROAD	Green
PROPOSED CONSTRUCTION	Red
COMMON PLOT	Yellow
ROAD WIDENING AREA	Blue
EXISTING (To be retained)	Light Blue
EXISTING (To be demolished)	Dark Blue

LTP NAME AND SIGNATURE	STRUCTURAL ENG'S NAME AND SIGNATURE	BUILDER NAME AND SIGNATURE	DIGITAL SIGNATURE
irshad hussain khan MJNPC/ENG/0002/2016			