

SITE PLAN (SCALE 1:200)

Buildingwise Floor FAR Details

Floor Name	A (BUILDING)		Total	
	Proposed Built Up Area (Sq.mt.)	Proposed FAR Area (Sq.mt.)	Total Proposed Built Up Area (Sq.mt.)	Total FAR Area (Sq.mt.)
Ground Floor	180.67	180.67	180.67	180.67
First Floor	195.46	195.46	195.46	195.46
Terrace Floor	0.00	0.00	0.00	0.00
Total :	376.13	376.13	376.13	376.13

Proposal Basic Information

Proposal File No.	RNP/BP/0019/W30/2019
Owner Name	MODI MAHTO
Khata No.	23
Plot No.	1018
Village Name	Village1
Use	Residential
SubUse	Bungalow/ Dwelling / Non Apartment

FAR & Tenement Details (Table 4c-1)

Building	No. of Same Bldg	Total Built Up Area (Sq.mt.)	Proposed FAR Area (Sq.mt.) Resi.	Total FAR Area (Sq.mt.)	Total Consumed Additional FAR Area (Sq.mt.)	Tnmt (No.)
A (BUILDING)	1	376.13	376.13	376.13	376.13	01
Grand Total :	1	376.13	376.13	376.13	376.13	01

COLOR INDEX

PLOT BOUNDARY	Black
ABUTTING ROAD	Green
PROPOSED CONSTRUCTION COMMON PLOT	Red
ROAD WIDENING AREA	Yellow
EXISTING (To be retained)	Blue
EXISTING (To be demolished)	Orange

Building USE/SUBUSE Details

Building Name	Building Use	Building SubUse	Building Structure
A (BUILDING)	Residential	Residential Bldg/Apartment	Non-Highrise

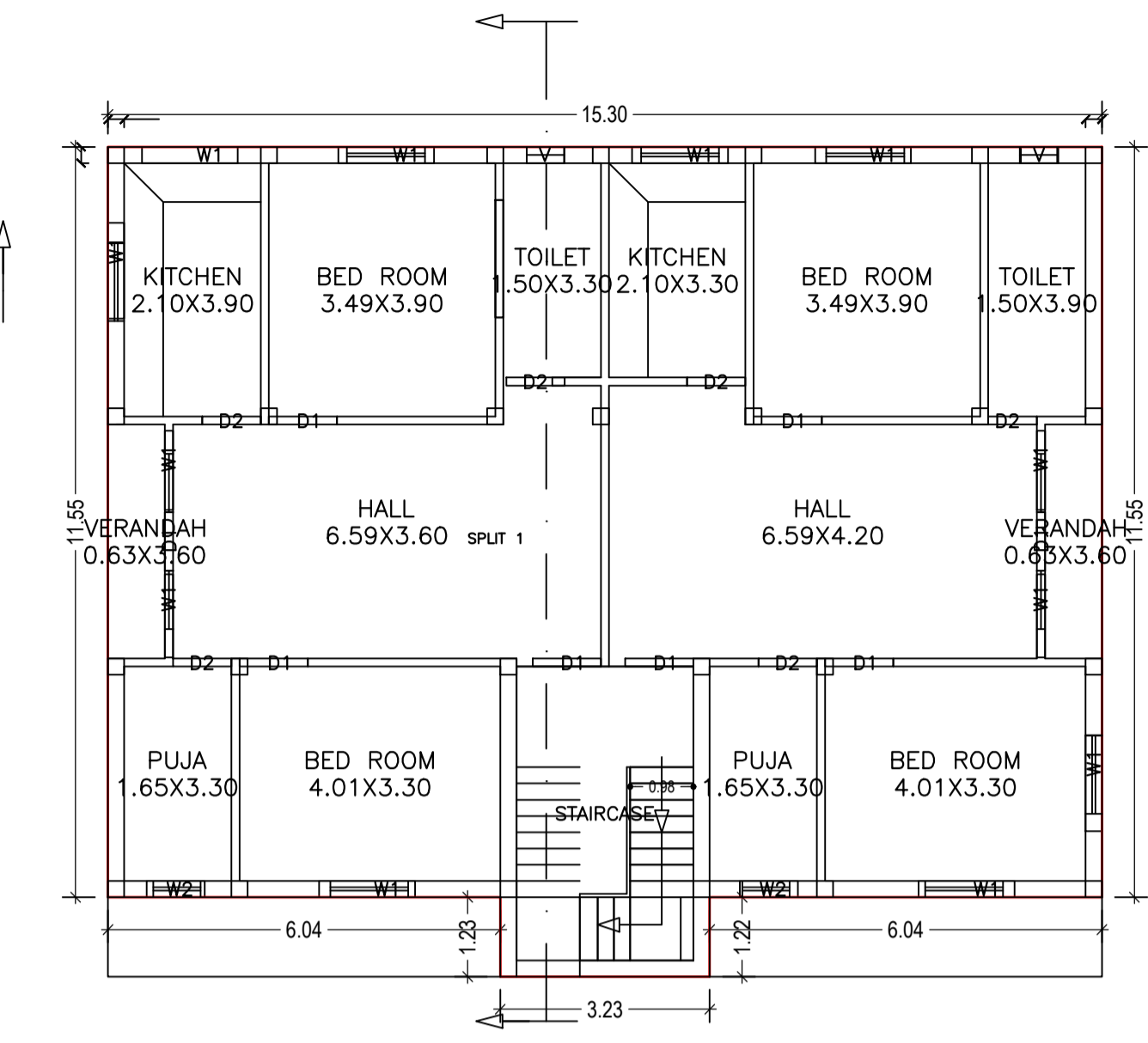

GROUND FLOOR PLAN (Proposed) (SCALE 1:100)

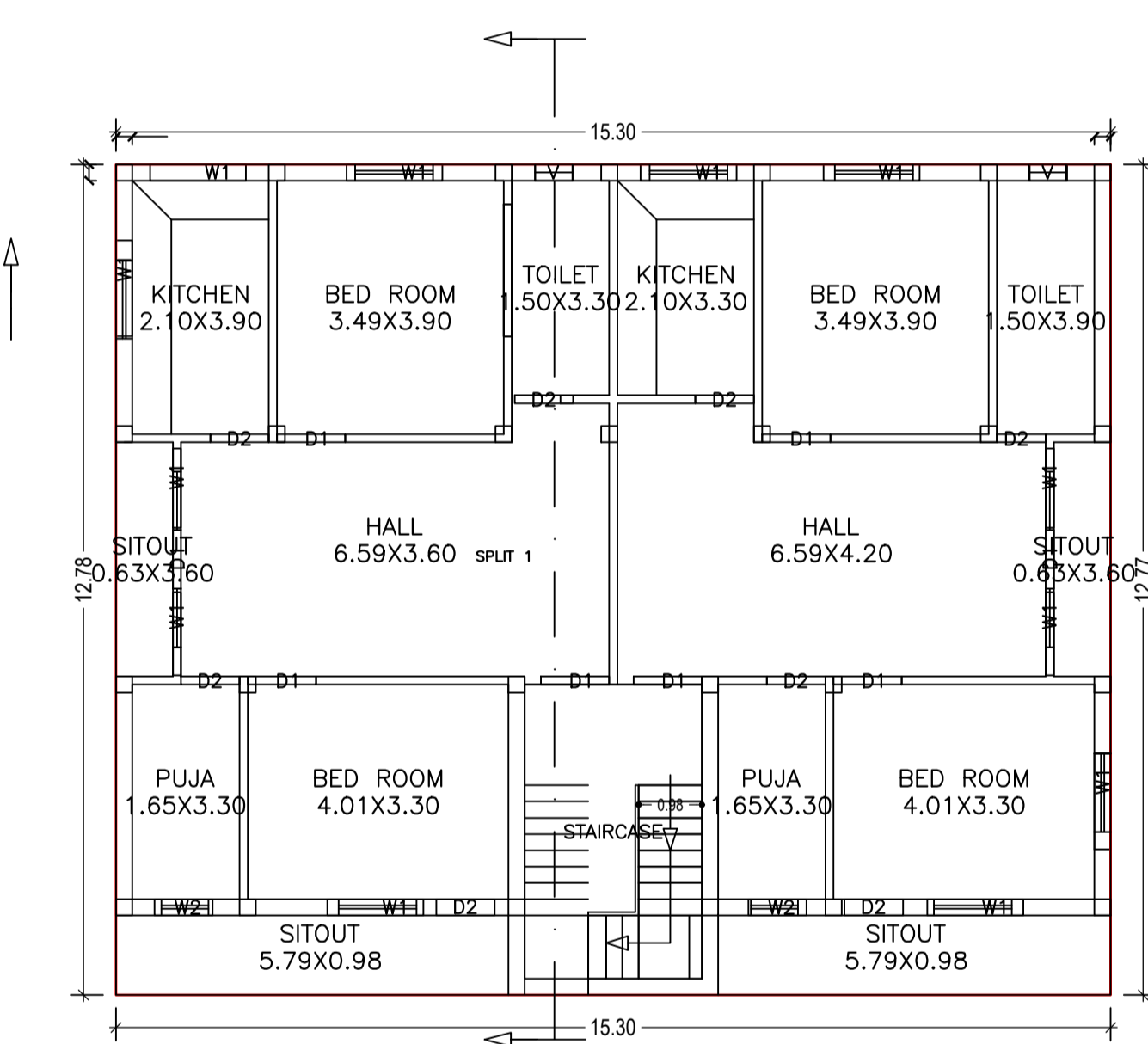

FIRST FLOOR PLAN (Proposed) (SCALE 1:100)

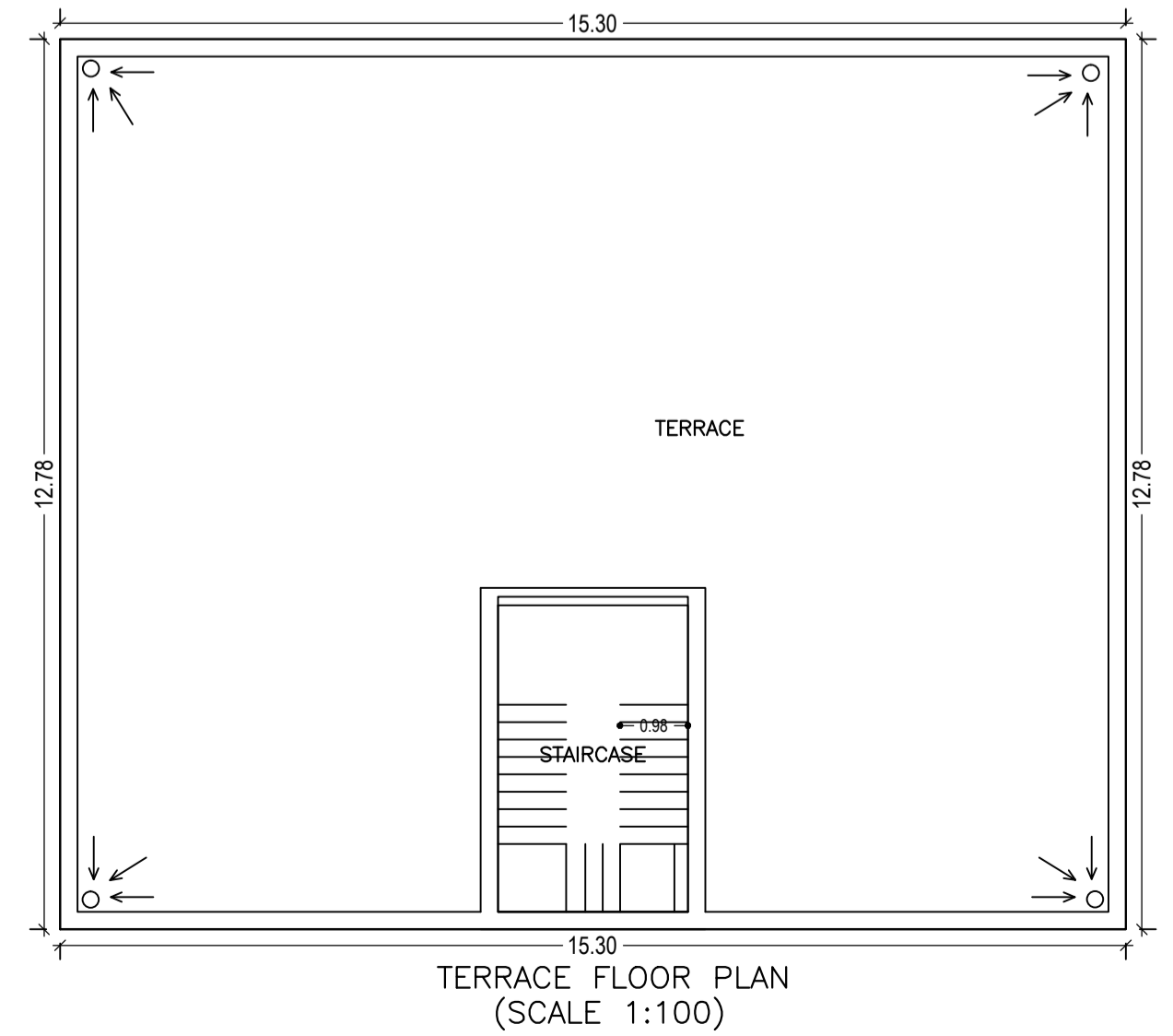

TERRACE FLOOR PLAN (SCALE 1:100)

AREA STATEMENT

AREA OF PLOT (Minimum)	(A)	SQ.MT.
AREA OF PLOT (Minimum)	(A)	461.97
Deduction for NetPlot Area		
Surrender Free of Cost		9.86
Total		9.86
NET AREA OF PLOT(Gross Plot Area - Deduction from Gross Plot area)	(A-Deductions)	452.11
Deduction for Balance Plot Area(from Gross Plot Area)		
Surrender Free of Cost		9.86
Common Plot		43.89
Total		53.76
BALANCE AREA OF PLOT(Net Plot Area - Recreational/Amenity space)	(A-Deductions)	408.21
PLOT AREA FOR COVERAGE(Net Plot Area)	(A-Deductions)	452.11
Plot Area for FAR (Net Plot Area + RoadWidening Area)	(A-Deductions)	461.97
COVERAGE CHECK		
Permissible Coverage area (60.00 %)		271.27
Proposed Coverage Area (39.96 %)		180.67
Total Prop. Coverage Area (39.96 %)		180.67
Balance coverage area (20.04 %)		90.60
FAR CHECK		
Perm. FAR Area (1.50)		692.96
Total Perm. FAR area		692.96
Residential FAR		376.12
Proposed FAR Area		376.12
Total Proposed FAR Area		376.12
Consumed FAR (Factor)		0.81
Balance FAR Area		316.84
BUILT UP AREA CHECK		
Total Proposed BuiltUp Area		376.13
ARCHITECT (Regd)	LALIT KUMAR	
ENGINEER (Regd)		
SUPERVISOR (Regd)		
OWNER (Regd)	MODI MAHTO	
DEVELOPMENT AUTHORITY	LOCAL BODY	

SCHEDULE OF DOOR:

BUILDING NAME	NAME	LENGTH	HEIGHT	NOS
A (BUILDING)	D2	0.75	2.10	02
A (BUILDING)	D2	0.90	2.10	12
A (BUILDING)	D1	0.90	2.10	04
A (BUILDING)	D1	1.05	2.10	12

SCHEDULE OF WINDOW/VENTILATION:

BUILDING NAME	NAME	LENGTH	HEIGHT	NOS
A (BUILDING)	V	0.58	1.20	04
A (BUILDING)	W2	0.89	1.20	04
A (BUILDING)	W1	1.22	1.20	04
A (BUILDING)	W1	1.28	1.20	04
A (BUILDING)	W1	1.48	1.20	16

Building :A (BUILDING)

Floor Name	Total Built Up Area (Sq.mt.)	Proposed FAR Area (Sq.mt.) Resi.	Total FAR Area (Sq.mt.)	Total Consumed Additional FAR Area (Sq.mt.)	Tnmt (No.)
Ground Floor	180.67	180.67	180.67	180.67	01
First Floor	195.46	195.46	195.46	195.46	00
Terrace Floor	0.00	0.00	0.00	0.00	00
Total :	376.13	376.13	376.13	376.13	01
Total Number of Same Buildings	1				
Total :	376.13	376.13	376.13	376.13	01

UnitBUA Table for Building :A (BUILDING)

FLOOR	Name	UnitBUA Type	UnitBUA Area	Carpet Area	No. of Rooms	No. of Tenement
GROUND FLOOR PLAN	SPLIT 1	FLAT	348.55	348.07	14	1
FIRST FLOOR PLAN	SPLIT 1	FLAT	0.00	0.00	16	0
Total:	-	-	348.55	348.07	30	1

LTP NAME AND SIGNATURE	STRUCTURAL ENG'S NAME AND SIGNATURE	BUILDER NAME AND SIGNATURE	DIGITAL SIGNATURE
LALIT KUMAR RNP/DFTMM/0003/2017			

Proposal Basic Information	
Proposal File No.	RNP/BP/0019/W30/2019
Owner Name	MODI MAHTO
Khata No	23
Plot No	1018
Village Name	Village1
Use	Residential
SubUse	Bungalow/ Dwelling / Non Apartment

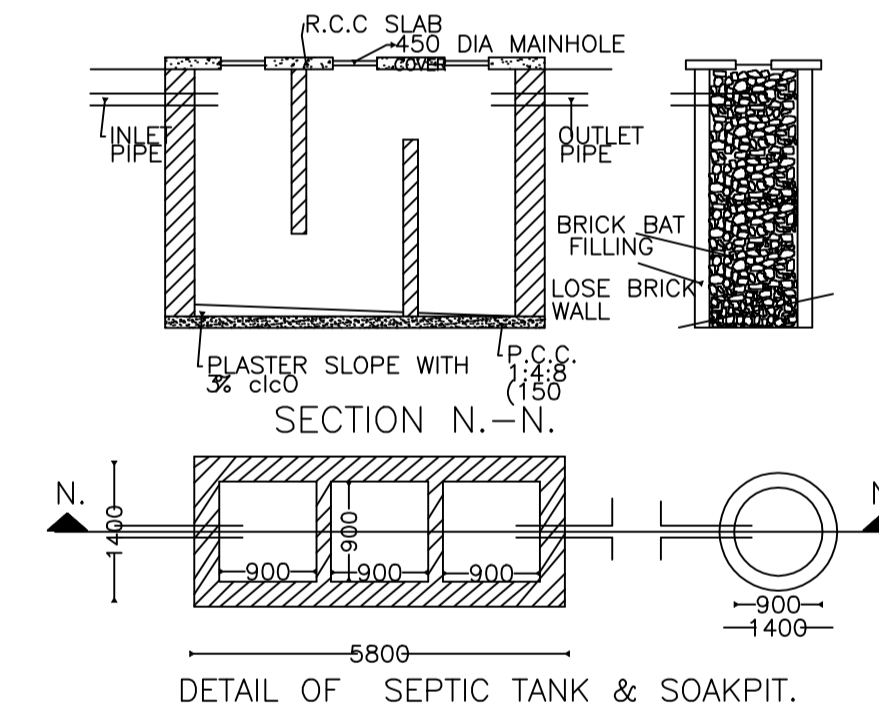
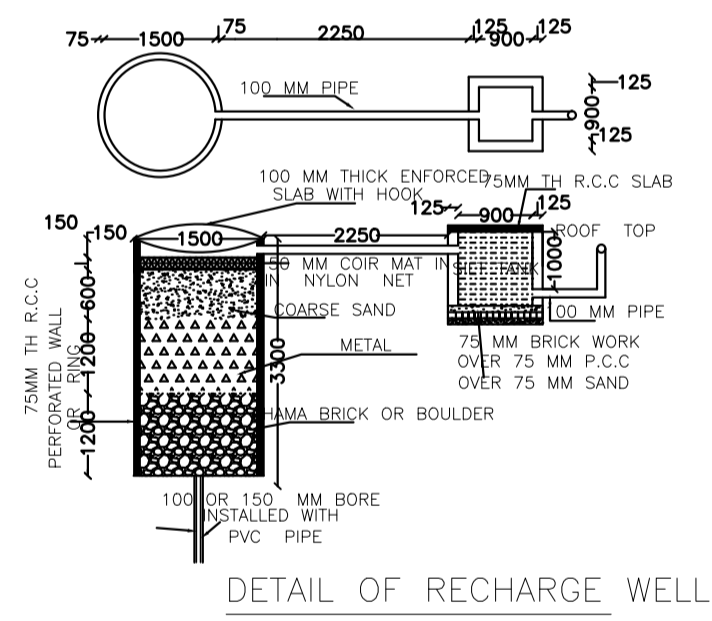
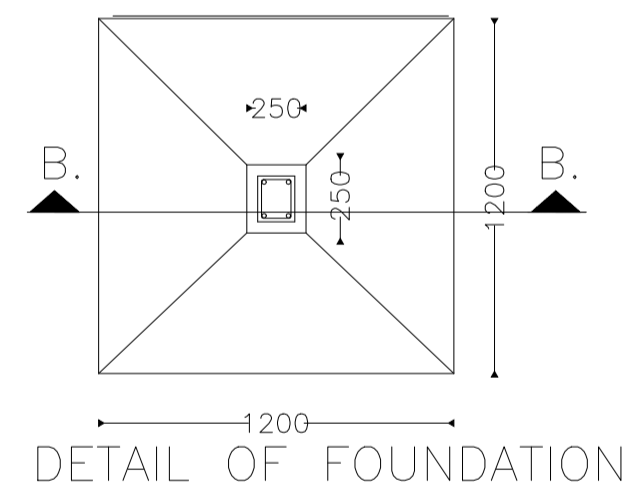
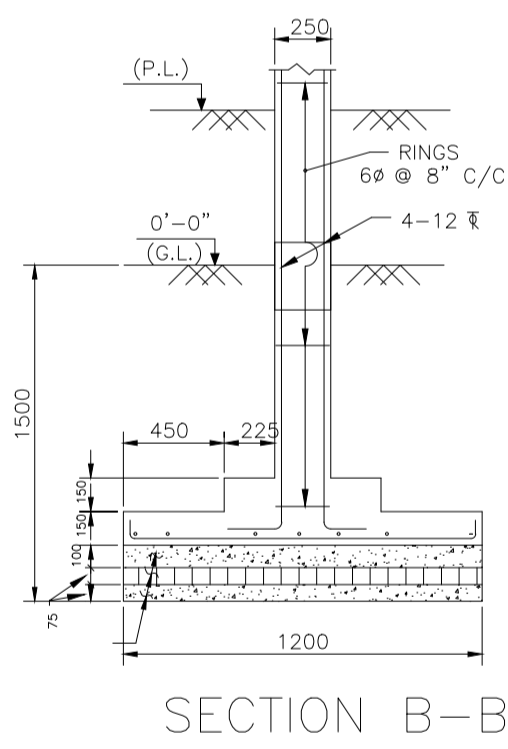
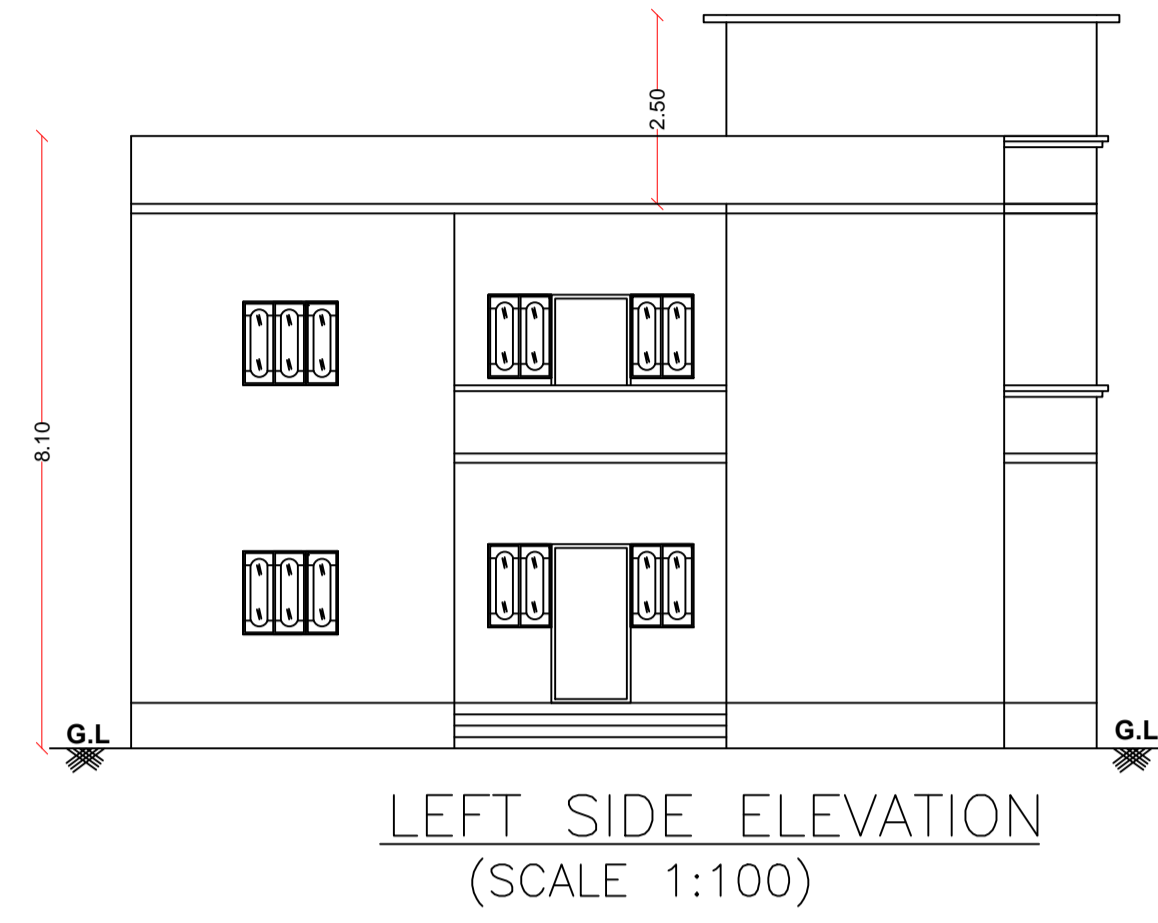
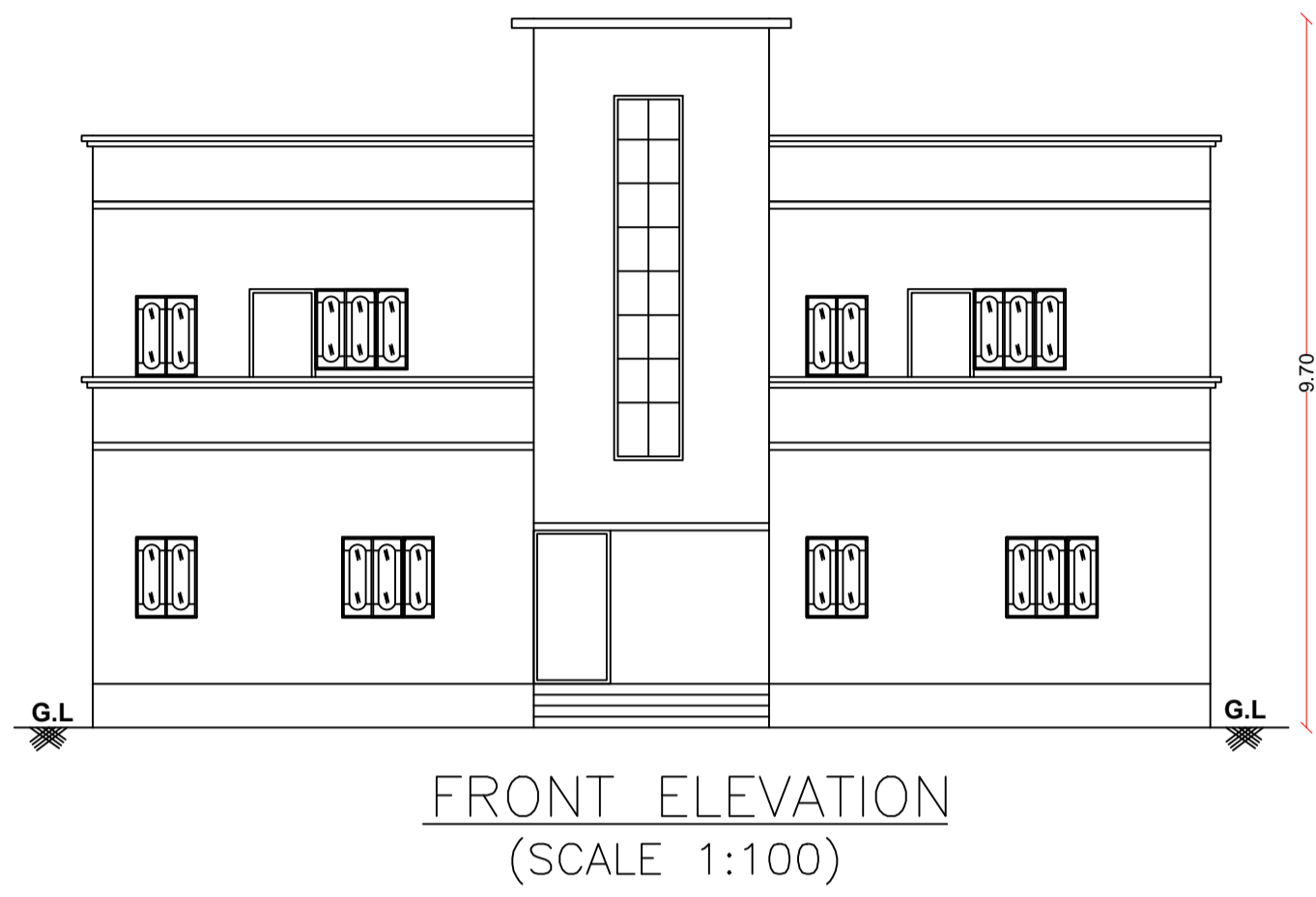

LTP NAME AND SIGNATURE	STRUCTURAL ENG'S NAME AND SIGNATURE	BUILDER NAME AND SIGNATURE	DIGITAL SIGNATURE
LALIT KUMAR RNP/DFTMN/0003/2017			