

FAR & Tenement Details (Table 4c-1)

Building	No. of Same Bldg	Total Built Up Area (Sq.mt.)	Deductions (Area in Sq.mt.)	Proposed FAR Area (Sq.mt.)	Total FAR Area (Sq.mt.)	Total Consumed Additional FAR Area (Sq.mt.)	Tnmt (No.)
I (BUILDING)	1	243.72	34.79	208.93	208.93	208.93	01
Grand Total :	1	243.72	34.79	208.93	208.93	208.93	01

Proposal Basic Information

Proposal File No.	RNP/BP/0032/W19/2021
Owner Name	KANTI RAI
Khata No	65
Plot No	1218
Village Name	Village1
Use	Residential
SubUse	Bungalow/ Dwelling / Non Apartment

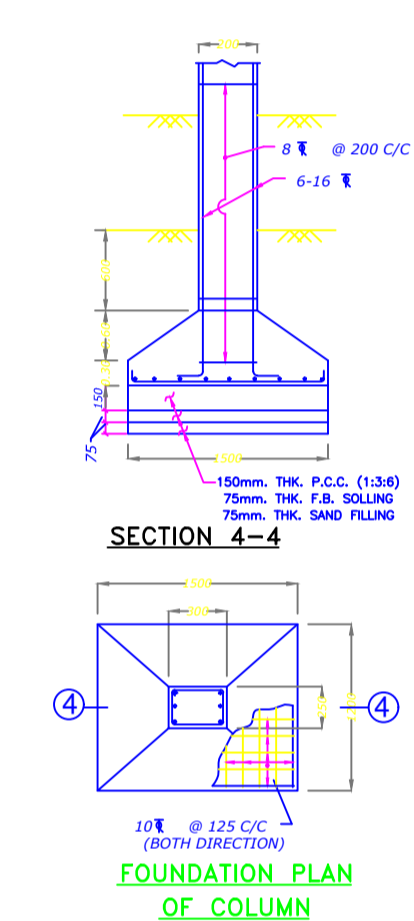
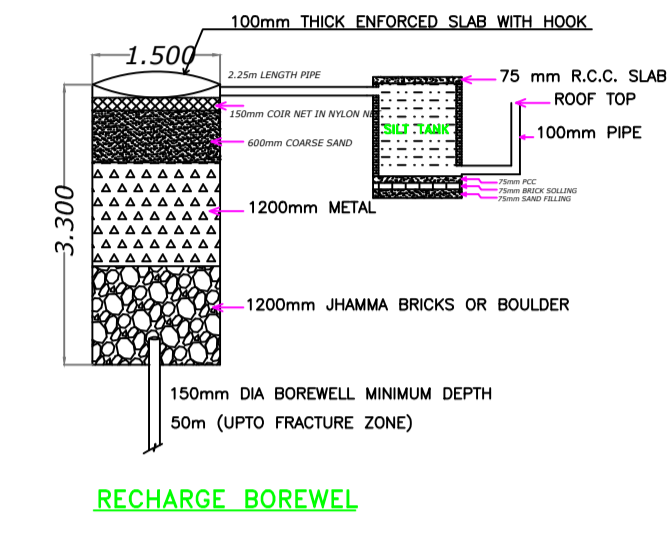

AREA STATEMENT
RAMGARH NAGAR PARISHAD

VERSION NO.: 1.0.64
VERSION DATE: 16/10/2020

AREA DETAILS:		SQ.MT.
AREA OF PLOT (Minimum)	(A)	233.80
NET AREA OF PLOT (Gross Plot Area - Deduction from Gross Plot area)	(A-Deductions)	233.80
Deduction for Balance Plot Area (from Gross Plot Area)		
Common Plot		13.48
Total		13.48
BALANCE AREA OF PLOT (Net Plot Area - Recreational/Amenity space)	(A-Deductions)	220.32
PLOT AREA FOR COVERAGE (Net Plot Area)	(A-Deductions)	233.80
Plot Area for FAR (Net Plot Area + Road Widening Area)	(A-Deductions)	233.80
COVERAGE CHECK		
Permissible Coverage area (70.00 %)		163.66
Proposed Coverage Area (52.12 %)		121.86
Total Prop. Coverage Area (52.12 %)		121.86
Balance coverage area (17.88 %)		41.80
FAR CHECK		
Perm. FAR Area (1.500)		350.70
Total Perm. FAR area		350.70
Residential FAR		208.93
Proposed FAR Area		208.93
Total Proposed FAR Area		208.93
Consumed FAR (Factor)		0.89
Balance FAR Area		141.77
BUILT UP AREA CHECK		
Total Proposed BuiltUp Area		243.72
ARCHITECT (Regd)	Ismail Ajad	
ENGINEER (Regd)		
SUPERVISOR (Regd)		
OWNER (Regd)	KANTI RAI	
DEVELOPMENT AUTHORITY LOCAL BODY		

SITE PLAN

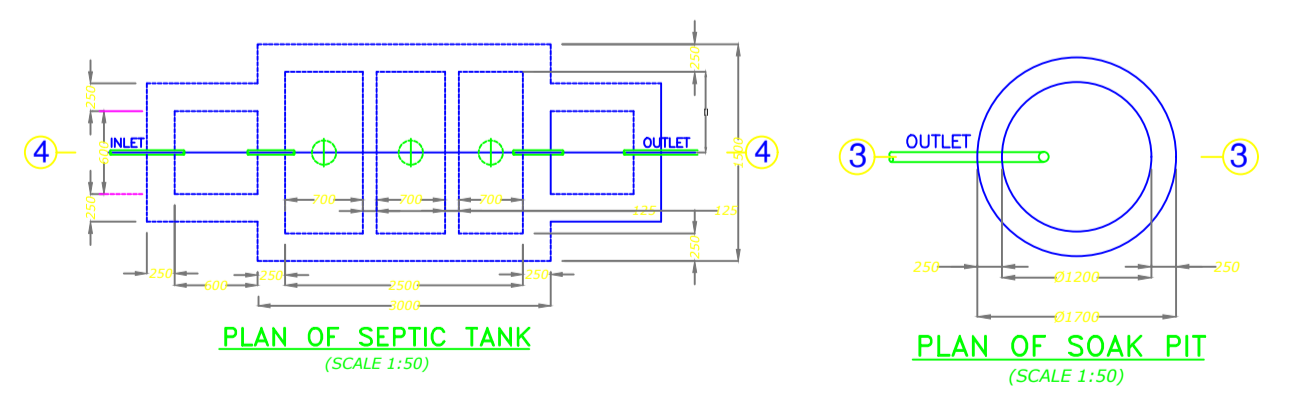
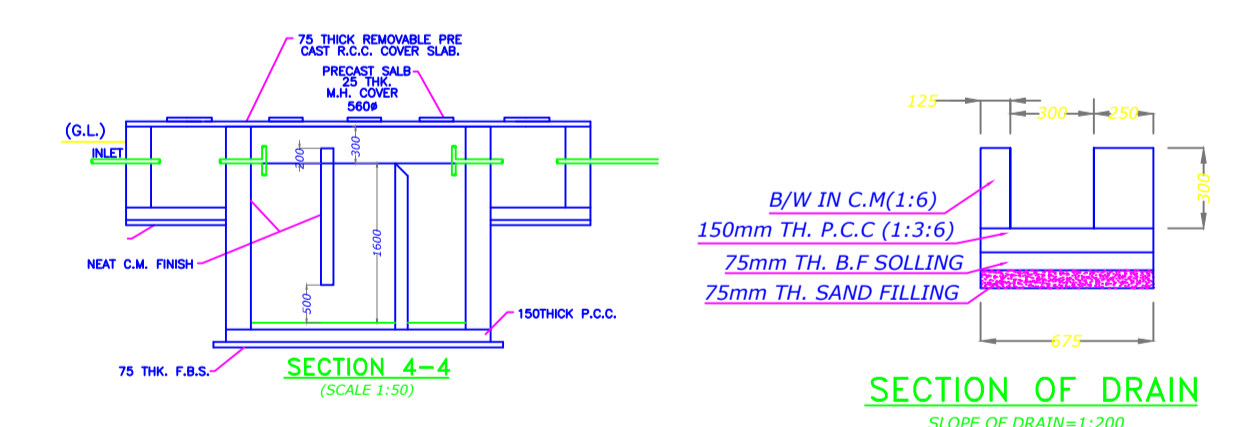
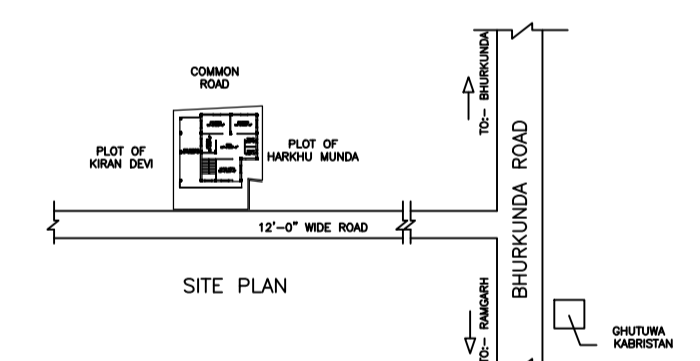
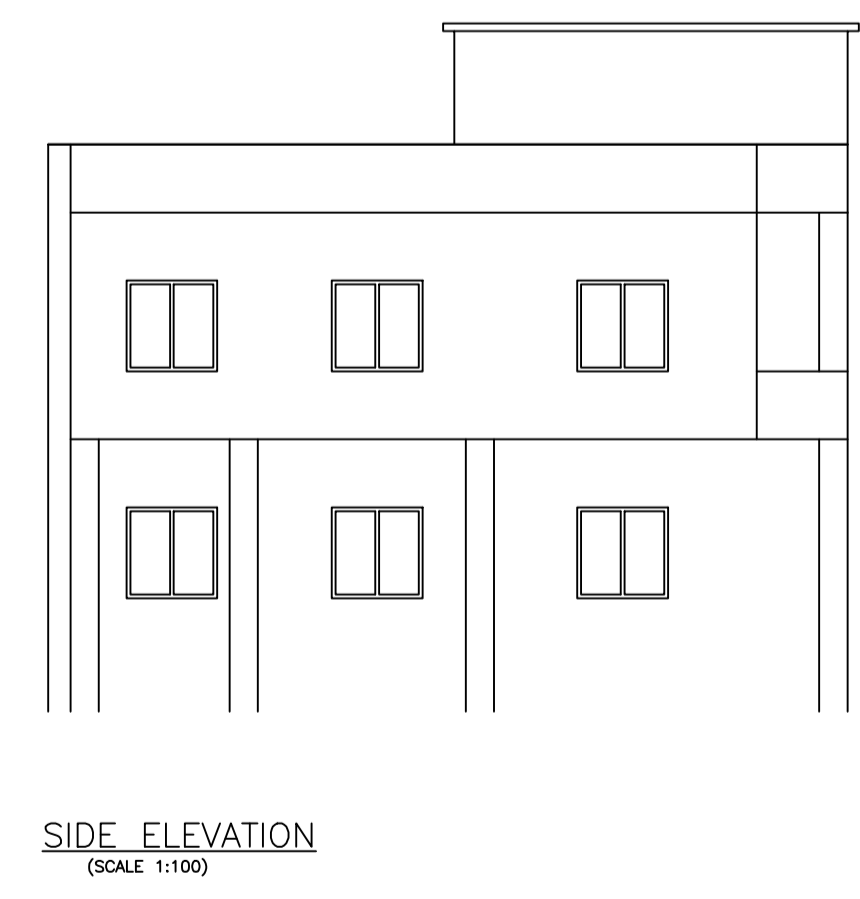
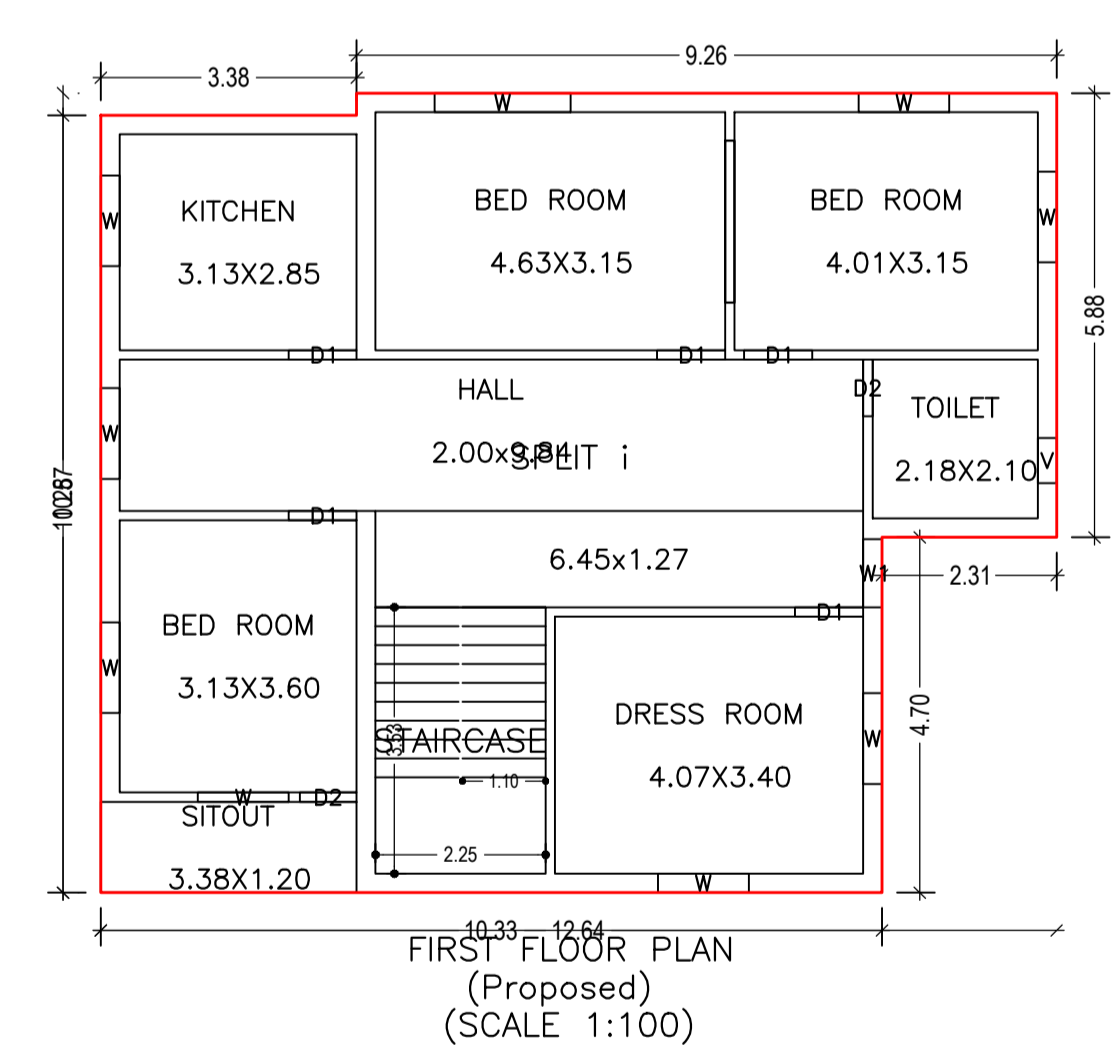
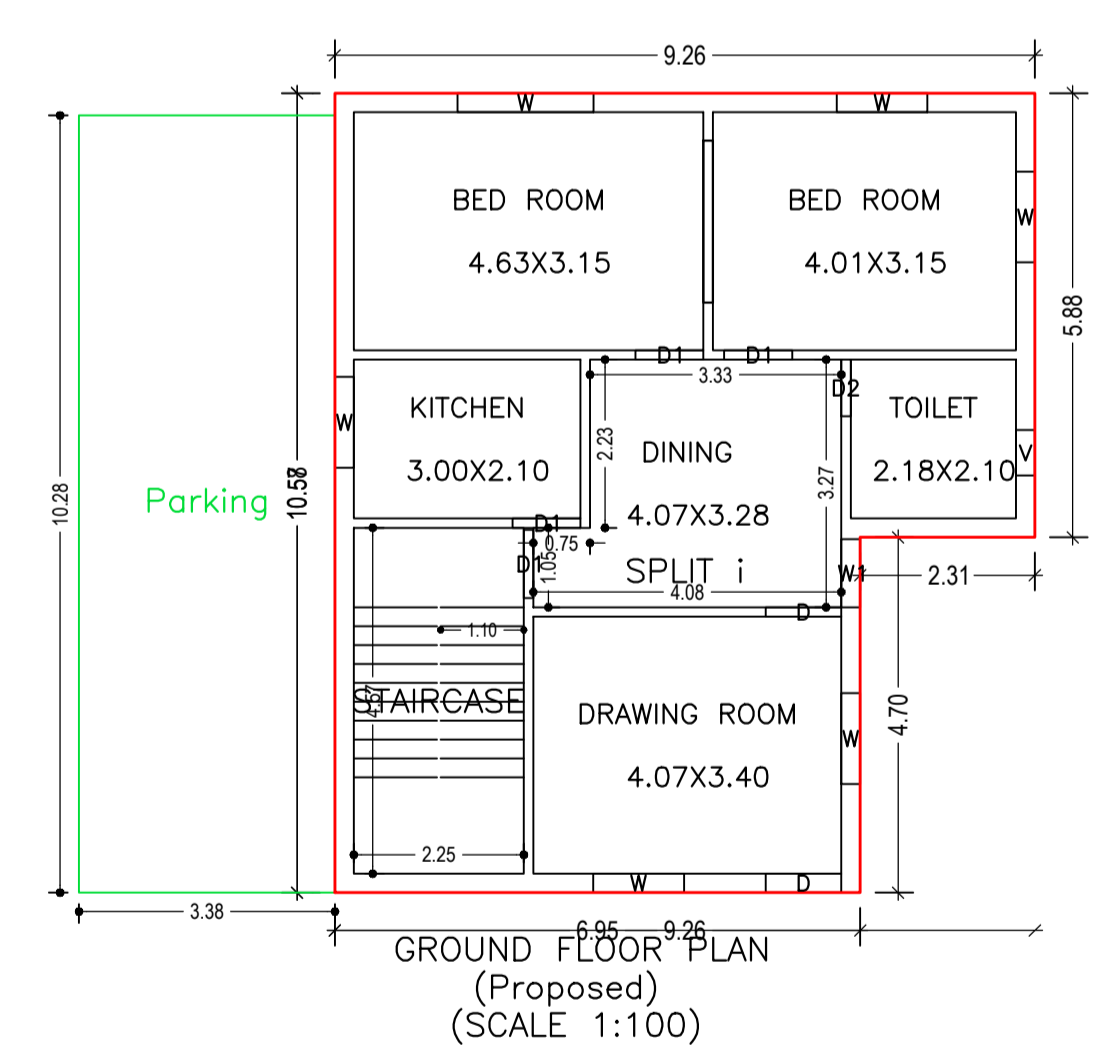

COLOR INDEX

PLOT BOUNDARY	Black
ABUTTING ROAD	Red
PROPOSED CONSTRUCTION	Green
COMMON PLOT	Yellow
ROAD WIDENING AREA	Orange
EXISTING (To be retained)	Blue
EXISTING (To be demolished)	Light Blue

Building : I (BUILDING)

Floor Name	Total Built Up Area (Sq.mt.)	Deductions (Area in Sq.mt.)	Proposed FAR Area (Sq.mt.)	Total FAR Area (Sq.mt.)	Total Consumed Additional FAR Area (Sq.mt.)	Tnmt (No.)
Ground Floor	121.86	34.79	87.07	87.07	87.07	01
First Floor	121.86	0.00	121.86	121.86	121.86	00
Terrace Floor	0.00	0.00	0.00	0.00	0.00	00
Total :	243.72	34.79	208.93	208.93	208.93	01
Total Number of Same Buildings	1					
Total :	243.72	34.79	208.93	208.93	208.93	01

SCHEDULE OF DOOR:

BUILDING NAME	NAME	LENGTH	HEIGHT	NOS
I (BUILDING)	D2	0.75	2.10	03
I (BUILDING)	D1	0.90	2.10	09
I (BUILDING)	D	1.00	2.10	02

SCHEDULE OF WINDOW/VENTILATION:

BUILDING NAME	NAME	LENGTH	HEIGHT	NOS
I (BUILDING)	V	0.60	0.60	02
I (BUILDING)	W1	0.90	1.20	02
I (BUILDING)	W	1.20	1.20	13
I (BUILDING)	W	1.80	1.20	02

UnitBUA Table for Building : I (BUILDING)

FLOOR	Name	UnitBUA Type	UnitBUA Area	Carpet Area	No. of Rooms	No. of Tenement
GROUND FLOOR PLAN	SPLIT i	FLAT	188.98	188.45	6	1
FIRST FLOOR PLAN	SPLIT i	FLAT	0.00	0.00	8	0
Total:	-	-	188.98	188.45	14	1

Buildingwise Floor FAR Details

Floor Name	Building Name I (BUILDING)		Total	
	Proposed Built Up Area (Sq.mt.)	Proposed FAR Area (Sq.mt.)	Total Proposed Built Up Area (Sq.mt.)	Total FAR Area (Sq.mt.)
Ground Floor	121.86	87.07	121.86	87.07
First Floor	121.86	121.86	121.86	121.86
Terrace Floor	0.00	0.00	0.00	0.00
Total :	243.72	208.93	243.72	208.93

Building USE/SUBUSE Details

Building Name	Building Use	Building SubUse	Building Structure
I (BUILDING)	Residential	Bungalow/ Dwelling / Non Apartment	Non-Highrise

LTP NAME AND SIGNATURE	STRUCTURAL ENG'S NAME AND SIGNATURE	BUILDER NAME AND SIGNATURE	DIGITAL SIGNATURE
Ismail Ajad RNP/DFTMM/0003/2019			