

FOUNDATION PLAN
OF COLUMN

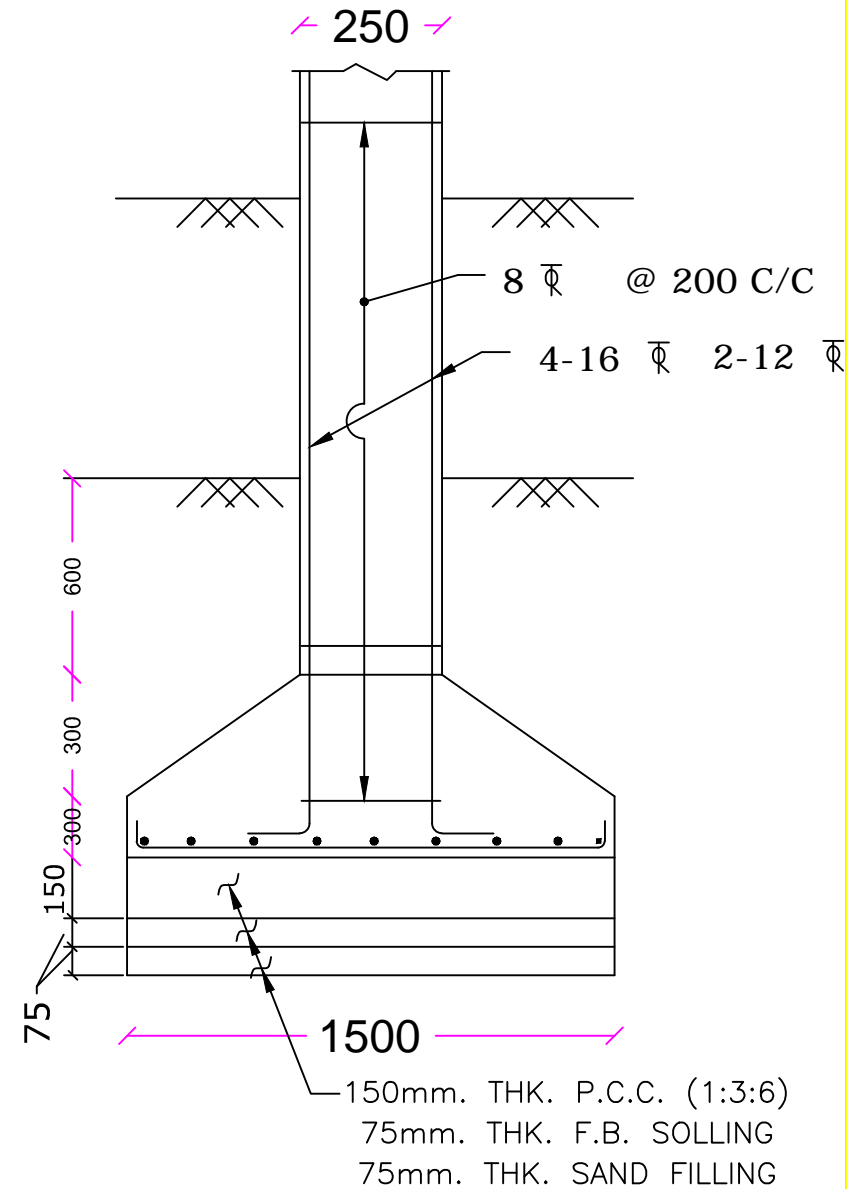

SECTION 4-4