

SITE PLAN
SCALE: -1:100

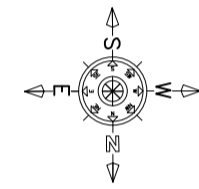

SITE PLAN

FAR & Tenement Details (Table 4c-1)

Building	No. of Same Bldg	Total Built Up Area (Sq.mt.)	Deductions (Area in Sq.mt.)	Proposed FAR Area (Sq.mt.)	Total FAR Area (Sq.mt.)	Total Consumed Additional FAR Area (Sq.mt.)	Tnmt (No.)
A (BUILDING)	1	62.89	Parking 9.44	53.45	53.45	53.45	01
Grand Total :	1	62.89	9.44	53.45	53.45	53.45	01

Proposal Basic Information

Proposal File No.	RNP/BP/0043/W11/2023
Owner Name	NANDLAL RAM
Khata No	71
Plot No	763
Village Name	Village1
Use	Residential
SubUse	Bungalow/ Dwelling / Non Apartment

AREA STATEMENT	VERSION NO. : 1.0.66
RAMGARH NAGAR	VERSION DATE: 16/10/2020
PARISHAD	
PROJECT DETAIL:	
Region: JHARKHAND URBAN LOCAL BODIES	Plot Use: Residential
District: RAMGARH	Plot SubUse: Bungalow/ Dwelling / Non Apartment
Authority: RAMGARH NAGAR PARISHAD	PlotNearbyReligiousStructure: NA
Inward No: RNP/BP/0043/W11/2023	Plot/SubPlot No: 763
Application Type: General Proposal	North: Road Width - 9.14
Project Type: Building Permission	South: -
Nature of Development: New	East: -
Location of Development Area: New Area	West: -
AREA DETAILS:	SQ.MT.
AREA OF PLOT (Minimum)	(A) 159.08
Deduction for NetPlot Area	
Surrender Free of Cost	53.67
Total	53.67
NET AREA OF PLOT(Gross Plot Area - Deduction from Gross Plot area)	(A-Deductions) 105.40
Deduction for Balance Plot Area(from Gross Plot Area)	
Surrender Free of Cost	53.67
Common Plot	10.21
Total	63.89
BALANCE AREA OF PLOT(Net Plot Area - Recreational/Amenity space)	(A-Deductions) 95.19
PLOT AREA FOR COVERAGE(Net Plot Area)	(A-Deductions) 105.40
Plot Area for FAR (Net Plot Area + RoadWidening Area)	(A-Deductions) 159.08
COVERAGE CHECK	
Permissible Coverage area (70.00 %)	73.78
Proposed Coverage Area (59.67 %)	62.89
Total Prop. Coverage Area (59.67 %)	62.89
Balance coverage area (10.33 %)	10.89
FAR CHECK	
Perm. FAR Area (2.000)	318.16
Total Perm. FAR area	318.16
Residential FAR	53.45
Proposed FAR Area	53.45
Total Proposed FAR Area	53.45
Consumed FAR (Factor)	0.34
Balance FAR Area	264.71
BUILT UP AREA CHECK	
Total Proposed BuiltUp Area	62.89
ARCHITECT (Regd)	Md Afroz Alam
ENGINEER (Regd)	
SUPERVISOR (Regd)	
OWNER (Regd)	NANDLAL RAM
DEVELOPMENT AUTHORITY	LOCAL BODY

COLOR INDEX	
PLOT BOUNDARY	[Red Line]
ABUTTING ROAD	[Green Line]
PROPOSED CONSTRUCTION	[Blue Line]
COMMON PLOT	[Yellow Line]
ROAD WIDENING AREA	[Orange Line]
EXISTING (To be retained)	[Purple Line]
EXISTING (To be demolished)	[Light Blue Line]

Buildingwise Floor FAR Details

Floor Name	Building Name A (BUILDING)		Total	
	Proposed Built Up Area (Sq.mt.)	Proposed FAR Area (Sq.mt.)	Total Proposed Built Up Area (Sq.mt.)	Total FAR Area (Sq.mt.)
Ground Floor	62.89	53.45	62.89	53.45
Terrace Floor	0.00	0.00	0.00	0.00
Total :	62.89	53.45	62.89	53.45

Building USE/SUBUSE Details

Building Name	Building Use	Building SubUse	Building Structure
A (BUILDING)	Residential	Bungalow/ Dwelling / Non Apartment	Non-Highrise

LTP NAME AND SIGNATURE	STRUCTURAL ENG'S NAME AND SIGNATURE	BUILDER NAME AND SIGNATURE	DIGITAL SIGNATURE
Md Afroz Alam RNP/ENG/0006/2017			

Proposal Basic Information

Proposal File No.	RNP/BP/0043/W11/2023
Owner Name	NANDLAL RAM
Khata No	71
Plot No	763
Village Name	Village1
Use	Residential
SubUse	Bungalow/ Dwelling / Non Apartment

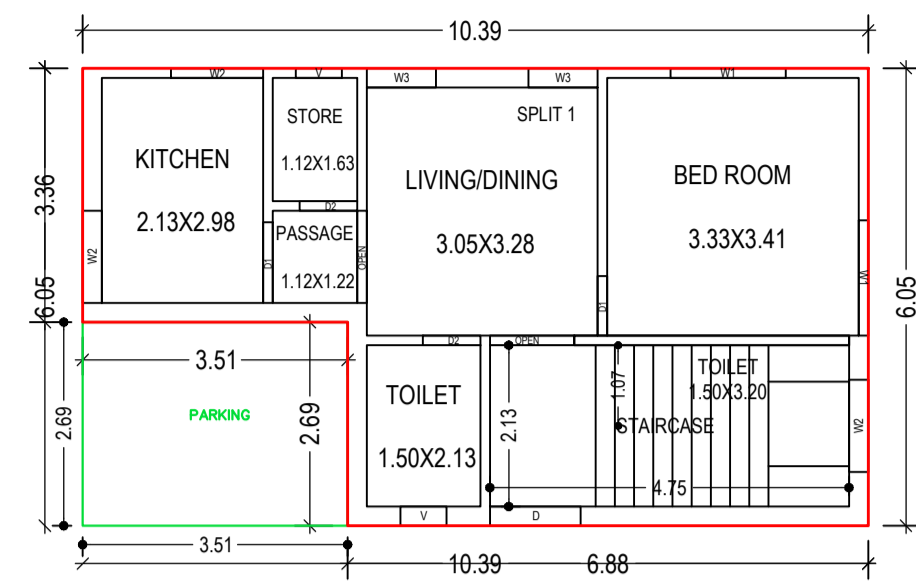

GROUND FLOOR PLAN (Proposed) (SCALE 1:100)

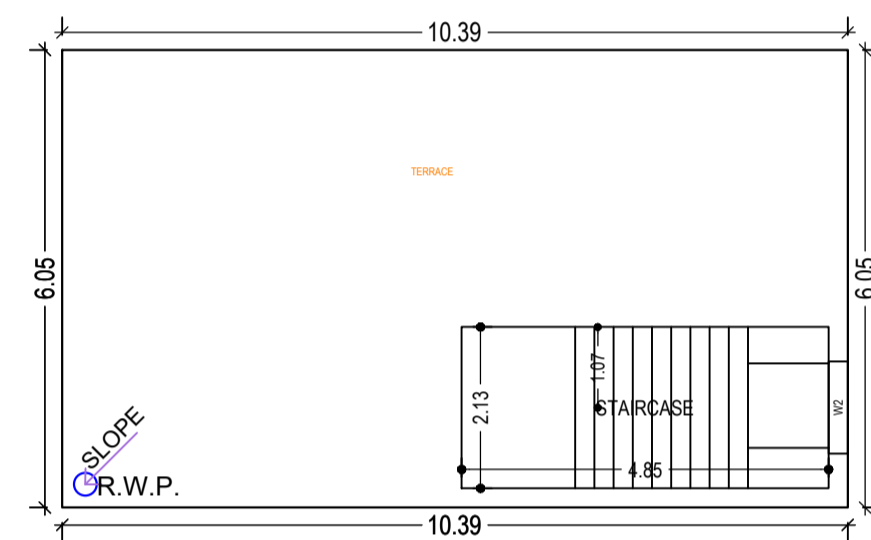

TERRACE FLOOR PLAN (SCALE 1:100)

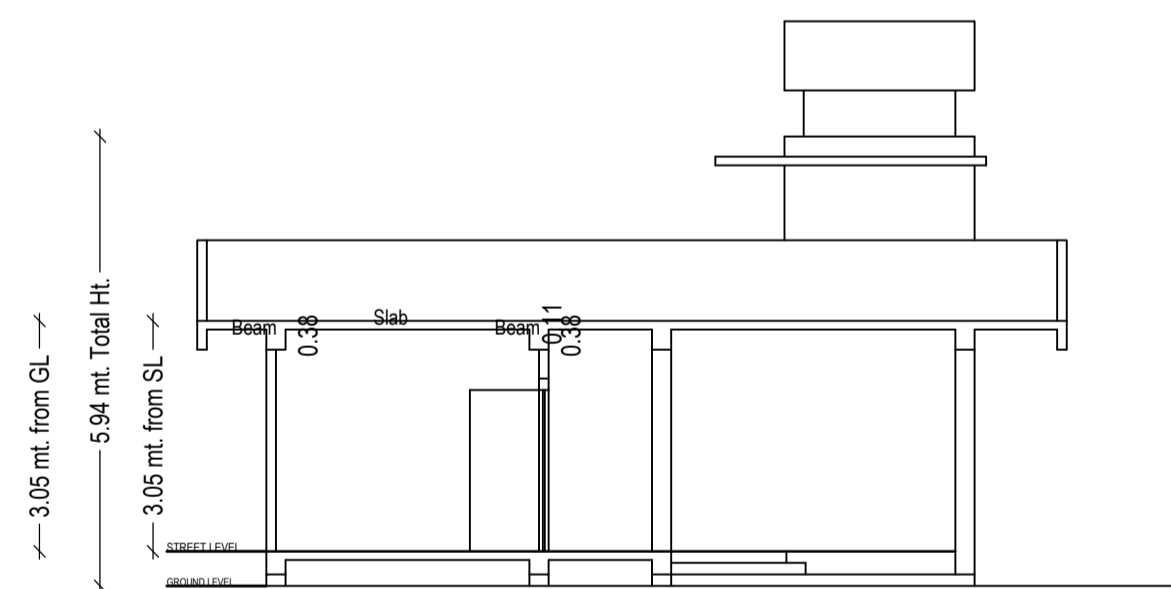

SECTION AT:-YY (SCALE:-1:100)

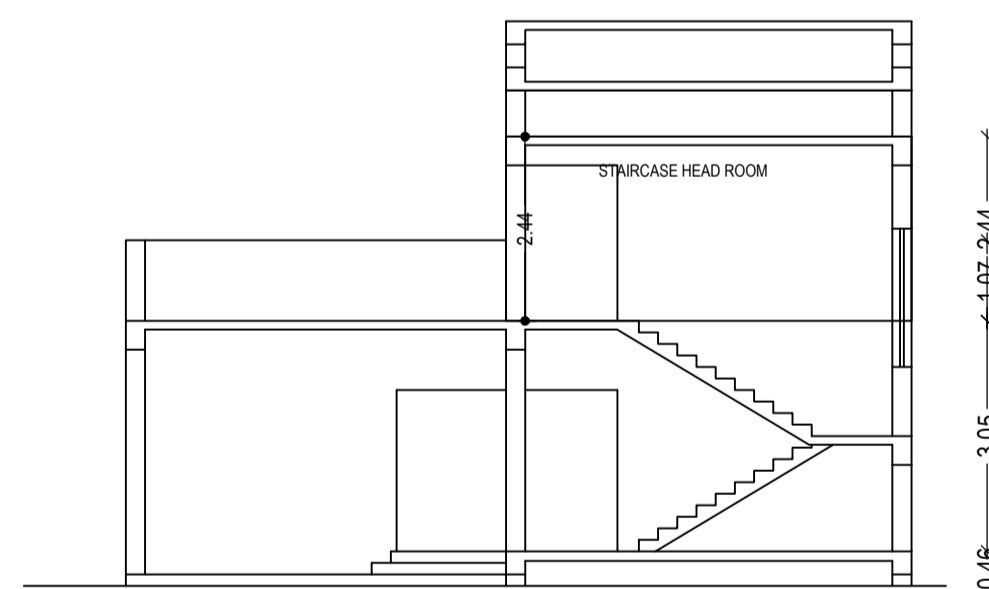

SECTION AT:-XX (SCALE:-1:100)

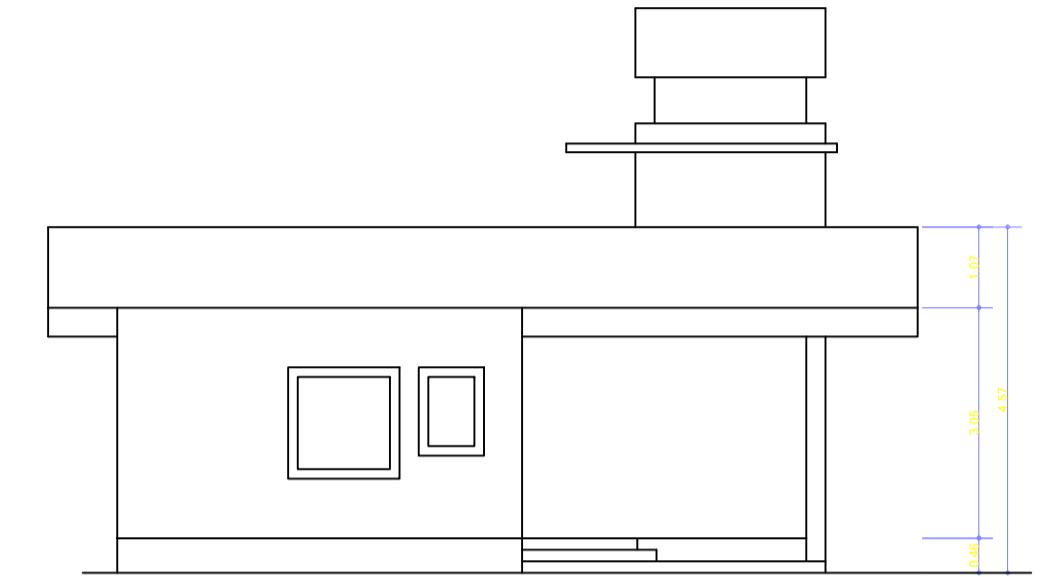
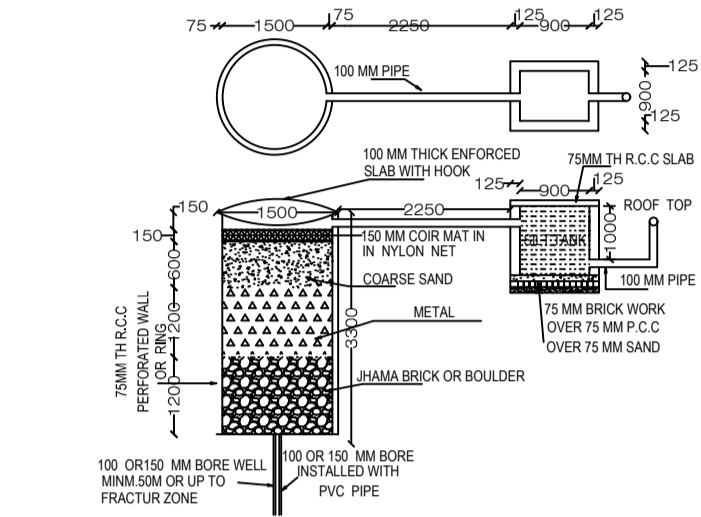

LEFT ELEVATION

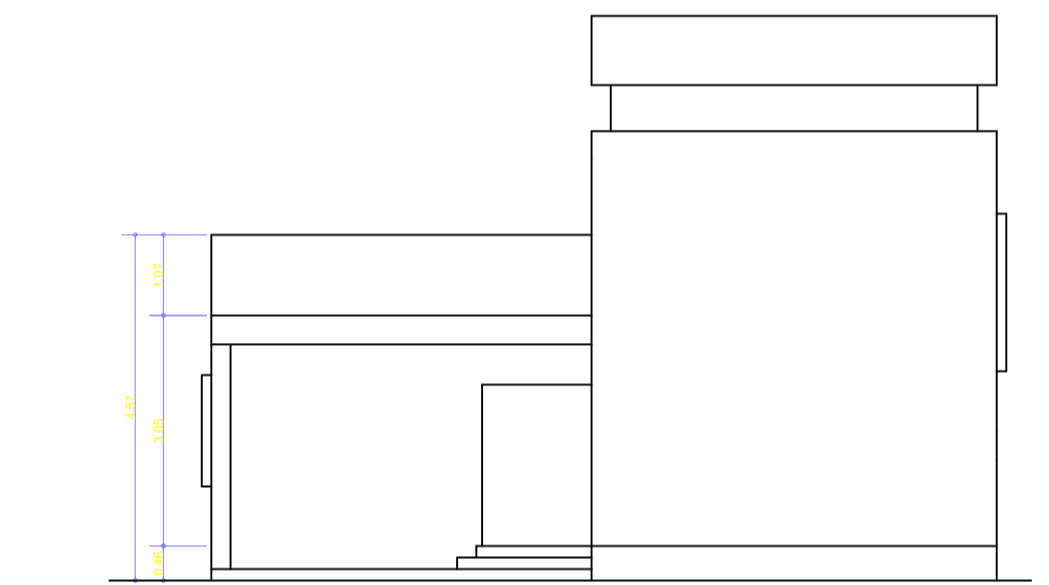
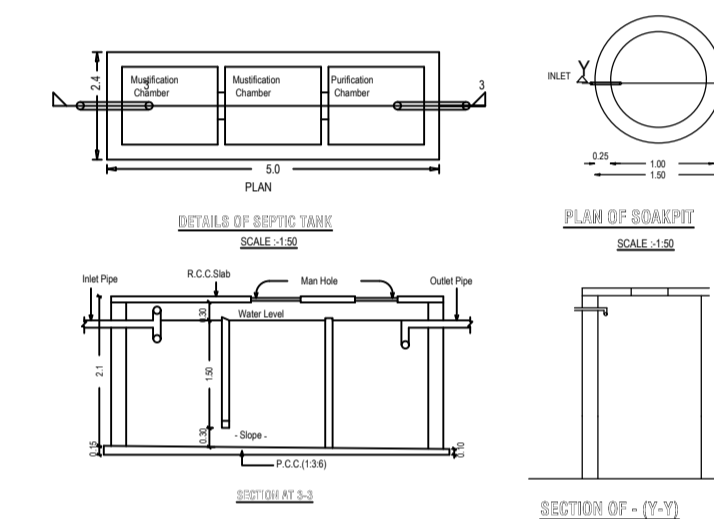

FRONT ELEVATION

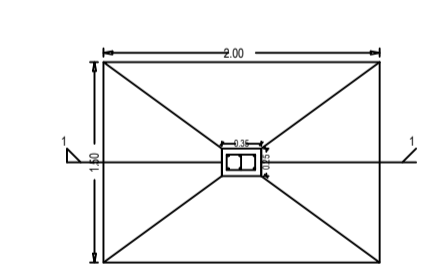
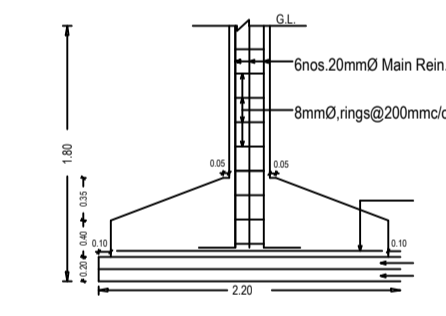

DETAILS OF FOUNDATION (SCALE:-1:50)

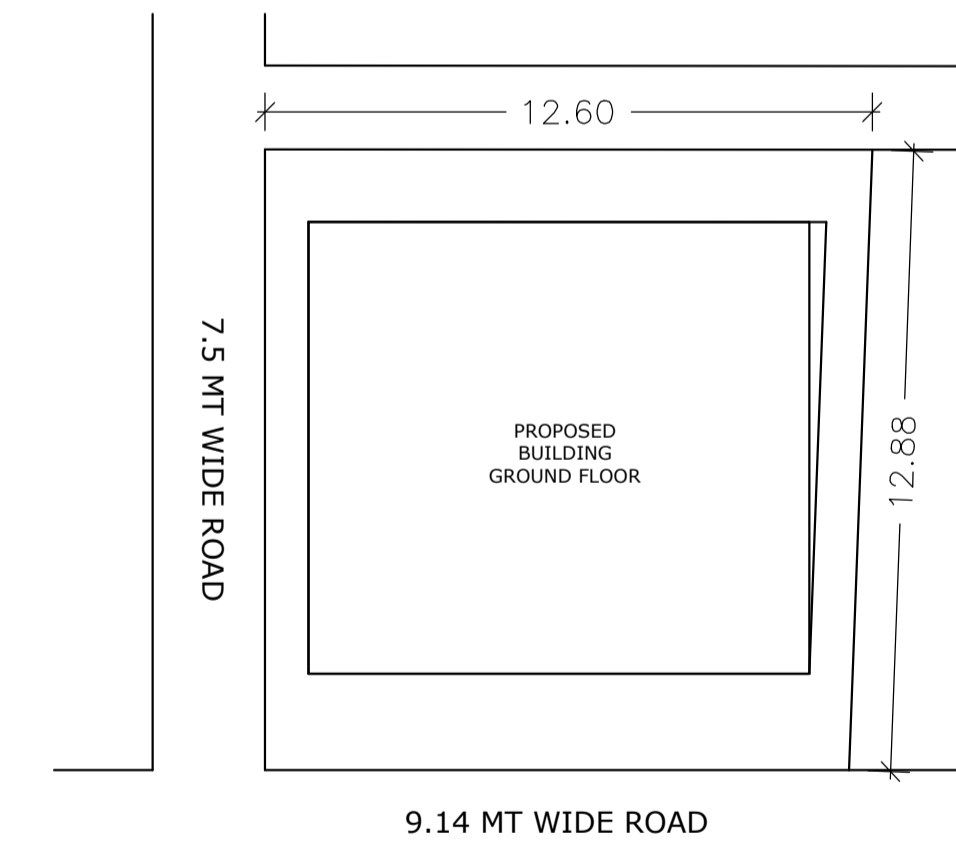

SITE PLAN (SCALE:-1:100)

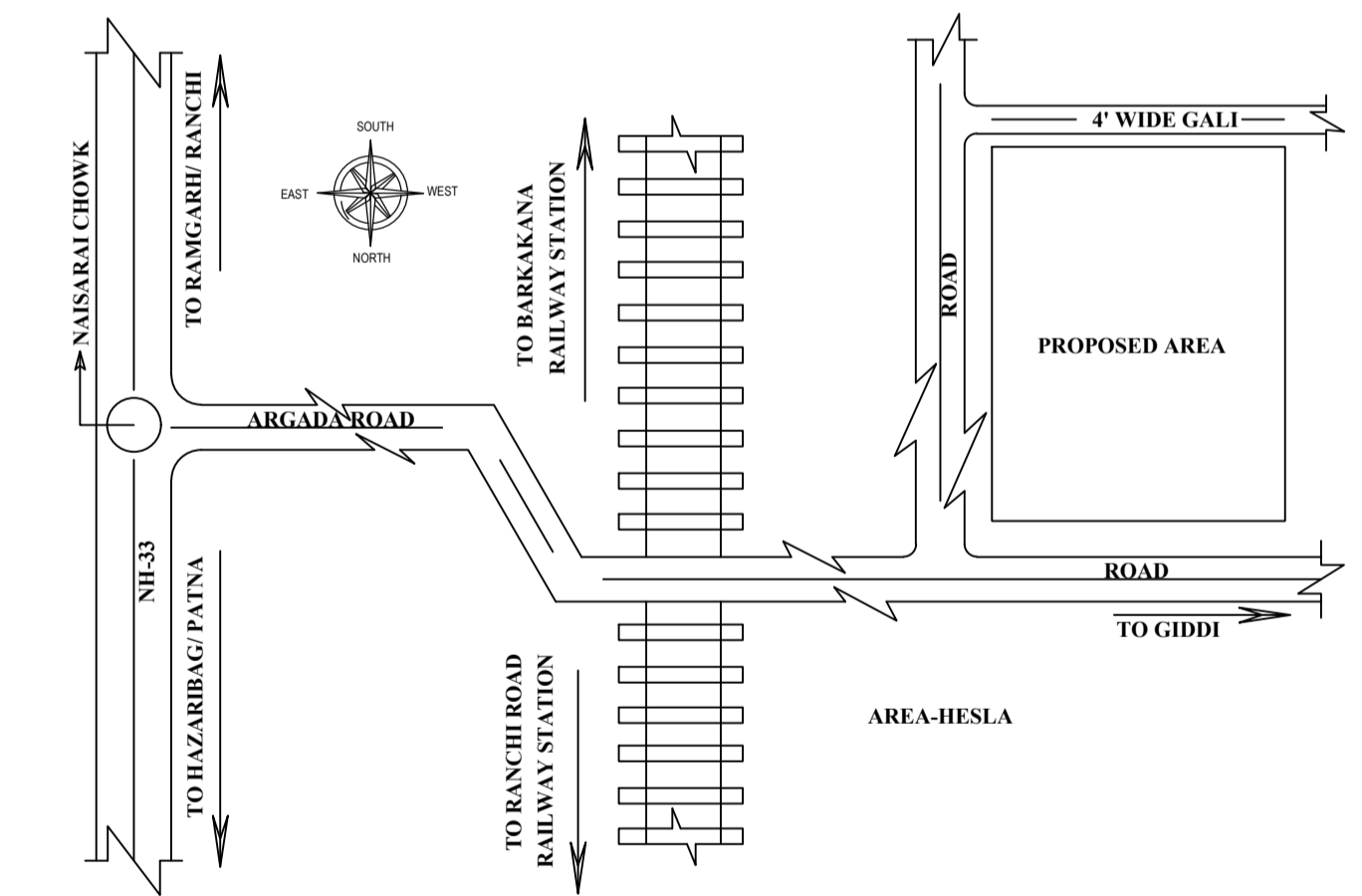

Building :A (BUILDING)

Floor Name	Total Built Up Area (Sq.mt.)	Deductions (Area in Sq.mt.)	Proposed FAR Area (Sq.mt.)	Total FAR Area (Sq.mt.)	Total Consumed Additional FAR Area (Sq.mt.)	Trmt (No.)
Ground Floor	62.89	9.44	53.45	53.45	53.45	01
Terrace Floor	0.00	0.00	0.00	0.00	0.00	00
Total :	62.89	9.44	53.45	53.45	53.45	01
Total Number of Same Buildings	1					
Total :	62.89	9.44	53.45	53.45	53.45	01

SCHEDULE OF DOOR:

BUILDING NAME	NAME	LENGTH	HEIGHT	NOS
A (BUILDING)	D2	0.76	2.10	02
A (BUILDING)	D1	0.79	2.10	01
A (BUILDING)	D1	1.07	2.10	01
A (BUILDING)	OPEN	1.12	2.10	01
A (BUILDING)	OPEN	1.22	2.10	01

SCHEDULE OF WINDOW/VENTILATION:

BUILDING NAME	NAME	LENGTH	HEIGHT	NOS
A (BUILDING)	V	0.61	1.20	02
A (BUILDING)	W3	0.91	1.20	02
A (BUILDING)	W2	1.22	1.20	04
A (BUILDING)	W1	1.52	1.20	02

UnitBUA Table for Building :A (BUILDING)

FLOOR	Name	UnitBUA Type	UnitBUA Area	Carpet Area	No. of Rooms	No. of Tenement
GROUND FLOOR PLAN	SPLIT 1	FLAT	46.62	46.16	6	1
Total:	-	-	46.62	46.16	6	1

LTP NAME AND SIGNATURE	STRUCTURAL ENG'S NAME AND SIGNATURE	BUILDER NAME AND SIGNATURE	DIGITAL SIGNATURE
Md Afroz Alam RNP/ENG/0006/2017			