

SITE PLAN

FAR & Tenement Details (Table 4c-1)

Building	No. of Same Bldg	Total Built Up Area (Sq.mt.)	Proposed FAR Area (Sq.mt.) Resi.	Total FAR Area (Sq.mt.)	Total Consumed Additional FAR Area (Sq.mt.)	Tnmt (No.)
A (SMT PREMA DEVI)	1	181.16	181.16	181.16	181.16	01
Grand Total :	1	181.16	181.16	181.16	181.16	01

Proposal Basic Information

Proposal File No.	RNP/3P/044/W02/2023
Owner Name	SMT PREMA DEVI
Khata No	52
Plot No	780
Village Name	Village
Use	Residential
SubUse	Bungalow/ Dwelling / Non Apartment

AREA STATEMENT	VERSION NO. : 1.0.66
RAMGARH NAGAR	VERSION DATE: 16/10/2020
PARISHAD	
PROJECT DETAIL:	
Region: JHARKHAND URBAN LOCAL BODIES	Plot Use: Residential
District: RAMGARH	Plot SubUse: Bungalow/ Dwelling / Non Apartment
Authority: RAMGARH NAGAR PARISHAD	PlotNearbyReligiousStructure: NA
Inward No: RNP/3P/044/W02/2023	Plot/SubPlot No: 780
Application Type: General Proposal	North: Road Width - 6.09
Project Type: Building Permission	South: -
Nature of Development Area: New	East: -
Location of Development Area: Old Area	West: -
AREA DETAILS:	SQ.MT.
AREA OF PLOT (Minimum)	(A) 214.05
NET AREA OF PLOT(Gross Plot Area - Deduction from Gross Plot area)	(A-Deductions) 214.05
Deduction for Balance Plot Area(from Gross Plot Area)	
Common Plot	38.65
Total	38.65
BALANCE AREA OF PLOT(Net Plot Area - Recreational/Amenity space)	(A-Deductions) 175.40
PLOT AREA FOR COVERAGE(Net Plot Area)	(A-Deductions) 214.05
Plot Area for FAR (Net Plot Area + RoadWidening Area)	(A-Deductions) 214.05
COVERAGE CHECK	
Permissible Coverage area (70.00 %)	149.84
Proposed Coverage Area (42.32 %)	90.58
Total Prop. Coverage Area (42.32 %)	90.58
Balance coverage area (27.69 %)	59.26
FAR CHECK	
Perm. FAR Area (1.800)	385.29
Total Perm. FAR area	385.29
Residential FAR	181.16
Proposed FAR Area	181.16
Total Proposed FAR Area	181.16
Consumed FAR (Factor)	0.85
Balance FAR Area	204.13
BUILT UP AREA CHECK	
Total Proposed BuiltUp Area	181.16
ARCHITECT (Regd)	ANKIT RAJ
ENGINEER (Regd)	
SUPERVISOR (Regd)	
OWNER (Regd)	SMT PREMA DEVI
DEVELOPMENT AUTHORITY	LOCAL BODY

COLOR INDEX	
PLOT BOUNDARY	Black
ABUTTING ROAD	Green
PROPOSED CONSTRUCTION	Red
COMMON PLOT	Yellow
ROAD WIDENING AREA	Orange
EXISTING (To be retained)	Blue
EXISTING (To be demolished)	Light Yellow

Buildingwise Floor FAR Details

Floor Name	Building Name A (SMT PREMA DEVI)		Total	
	Proposed Built Up Area (Sq.mt.)	Proposed FAR Area (Sq.mt.)	Total Proposed Built Up Area (Sq.mt.)	Total FAR Area (Sq.mt.)
Ground Floor	90.58	90.58	90.58	90.58
First Floor	90.58	90.58	90.58	90.58
Terrace Floor	0.00	0.00	0.00	0.00
Total :	181.16	181.16	181.16	181.16

Building USE/SUBUSE Details

Building Name	Building Use	Building SubUse	Building Structure
A (SMT PREMA DEVI)	Residential	Bungalow/ Dwelling / Non Apartment	Non-Highrise

LTP NAME AND SIGNATURE	STRUCTURAL ENG'S NAME AND SIGNATURE	BUILDER NAME AND SIGNATURE	DIGITAL SIGNATURE
ANKIT RAJ RNP/ENG/0004/2021			

Proposal Basic Information	
Proposal File No.	RNP/EN/044/W02/2023
Owner Name	SMT PREMA DEVI
Khata No	52
Plot No	780
Village Name	Village
Use	Residential
SubUse	Bungalow/ Dwelling / Non Apartment

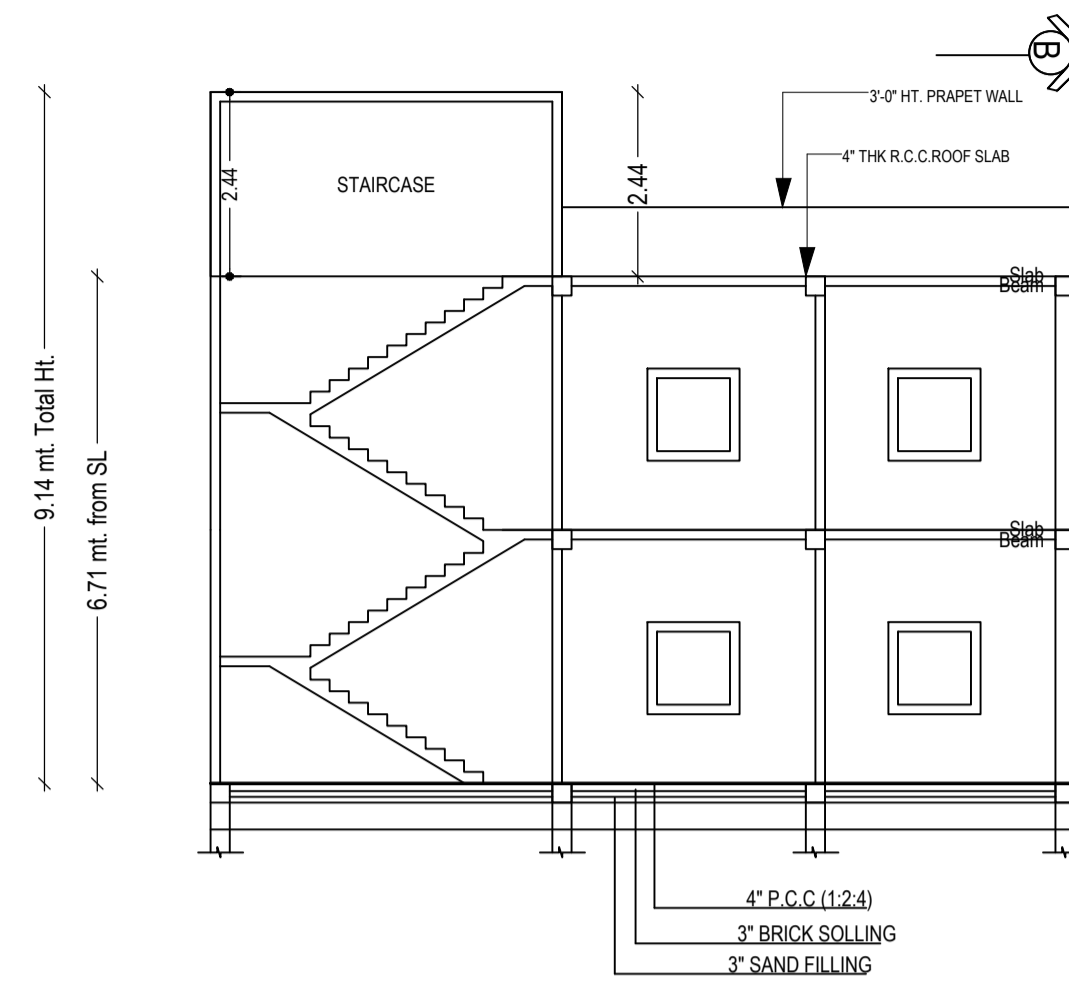
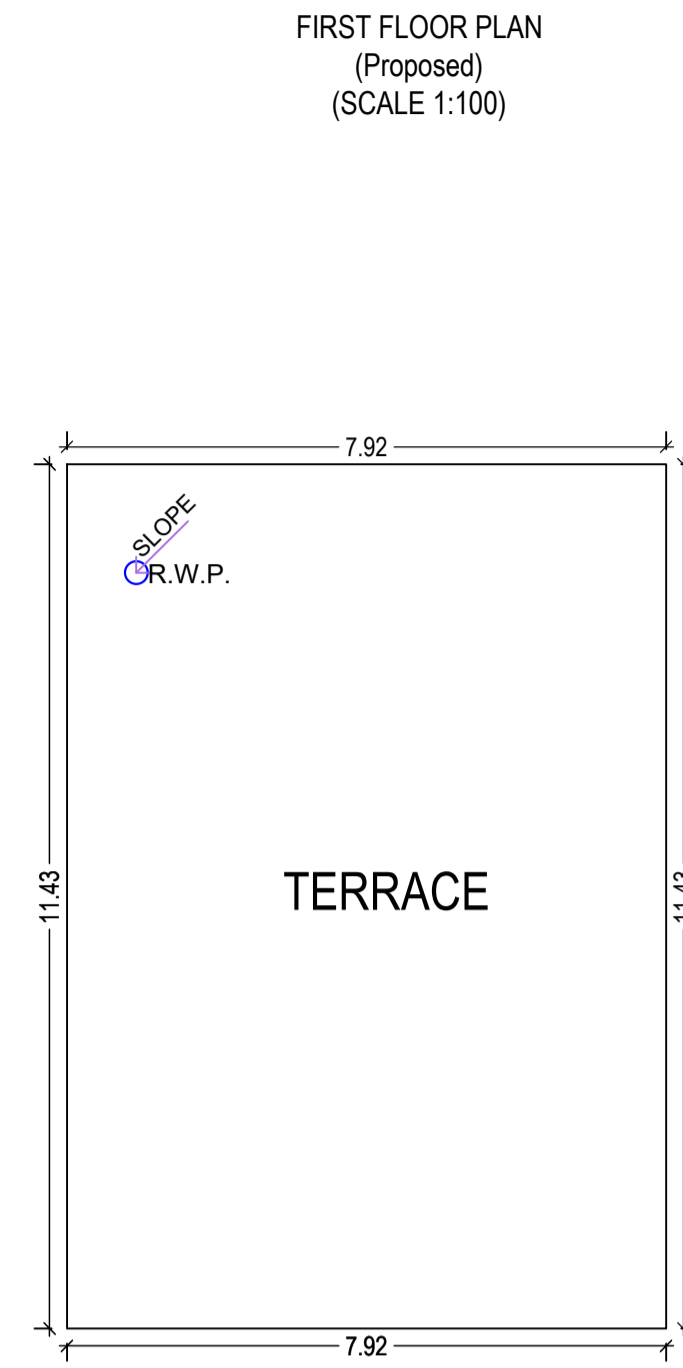
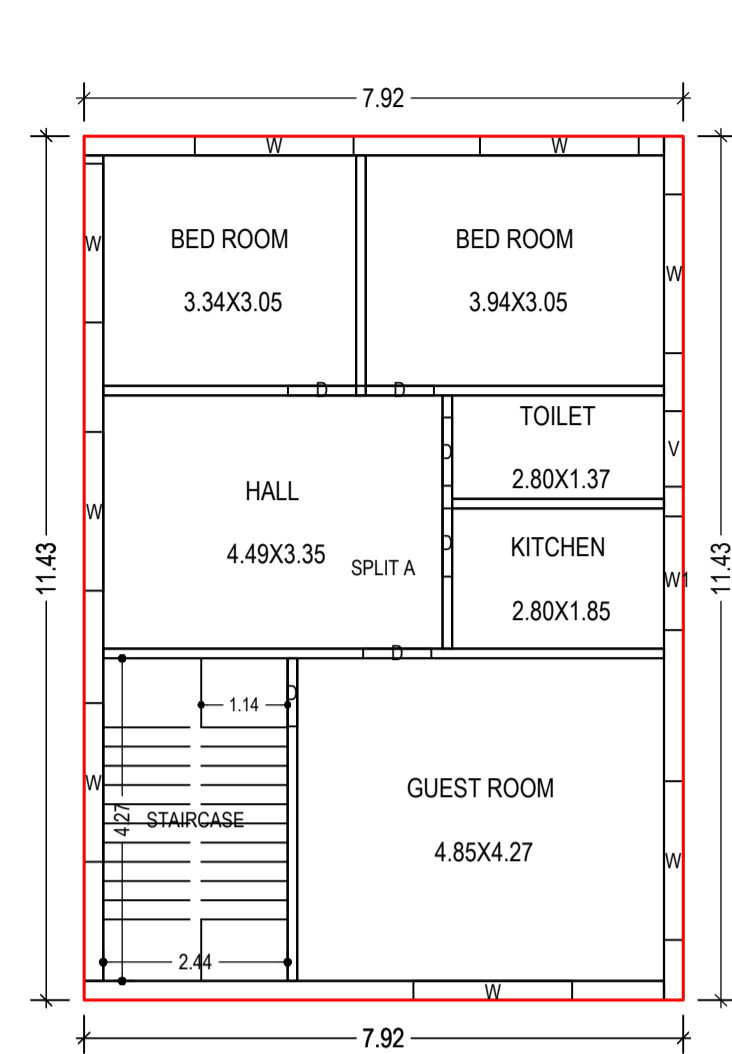
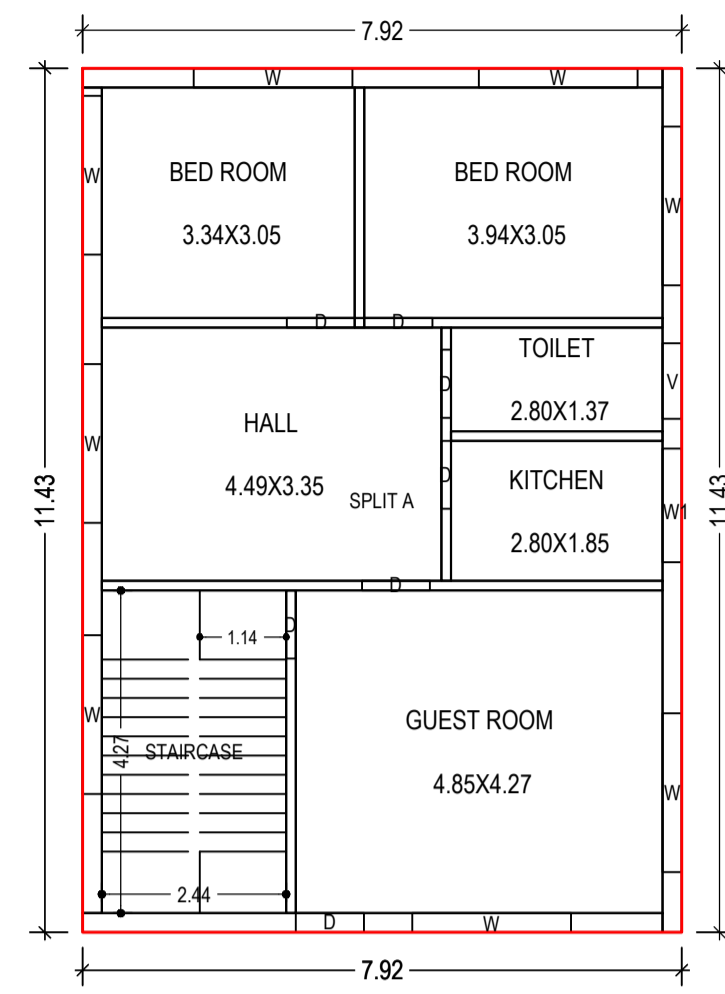

SECTION A-A

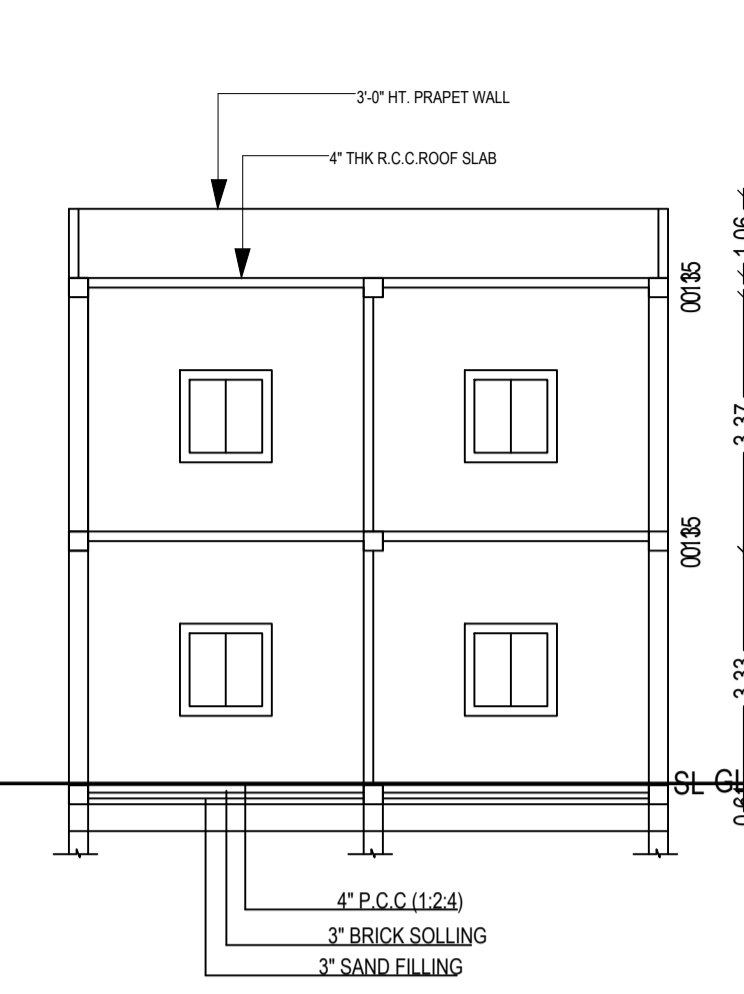

SECTION B-B

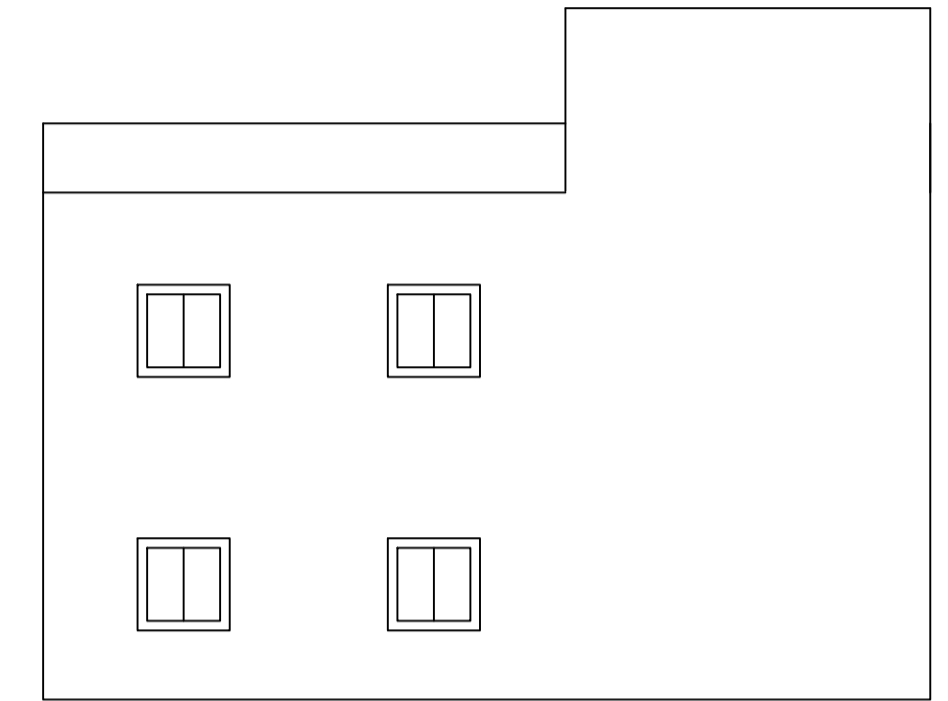

RIGHT SIDE ELEVATION

GROUND FLOOR PLAN
(Proposed)
(SCALE 1:100)

FIRST FLOOR PLAN
(Proposed)
(SCALE 1:100)

TERRACE FLOOR PLAN
(SCALE 1:100)

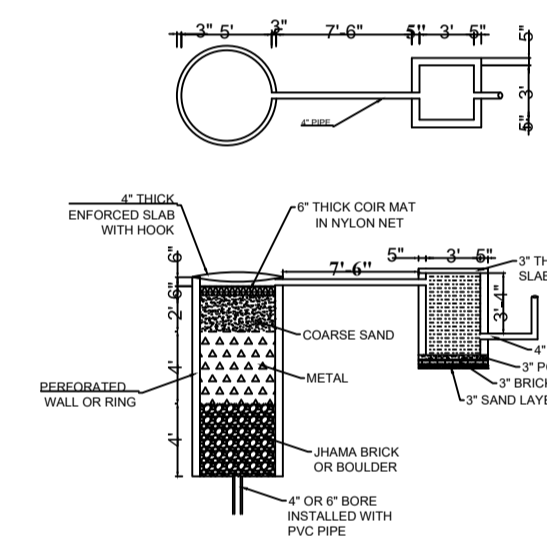

DETAIL OF RECHARGE WELL

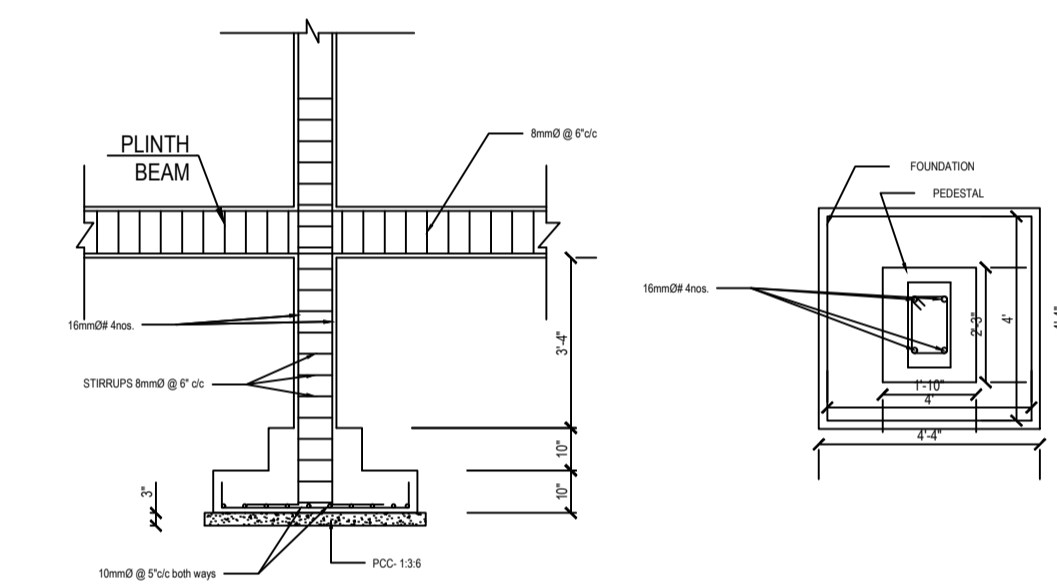

FOOTING AND COLUMN DETAIL

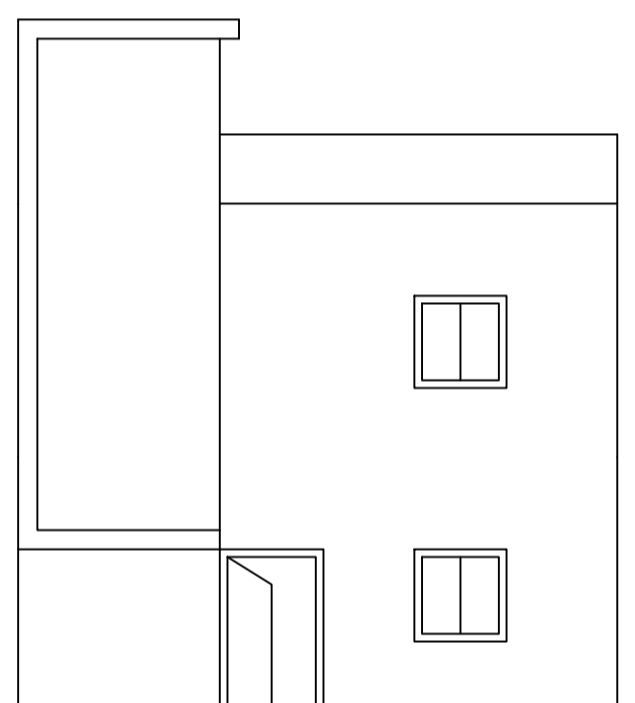

FRONT ELEVATION

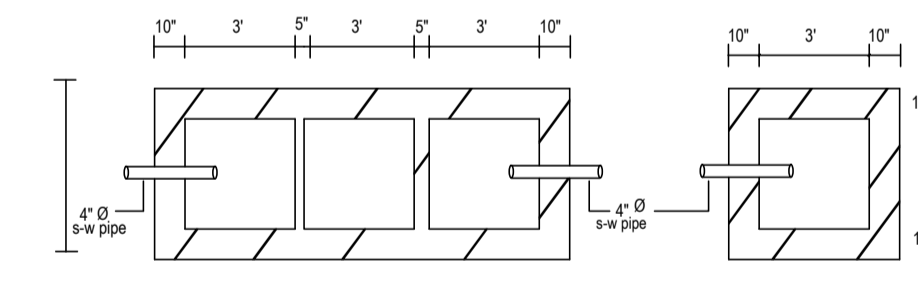

PLAN OF SEPTIC TANK & SOAK PIT

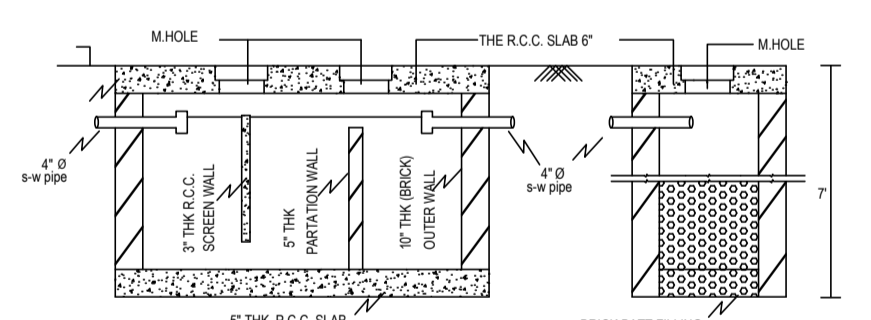

SECTION OF SEPTIC TANK AND SOAK PIT

Building :A (SMT PREMA DEVI)

Floor Name	Total Built Up Area (Sq.mt.)	Proposed FAR Area (Sq.mt.) Resi.	Total FAR Area (Sq.mt.)	Total Consumed Additional FAR Area (Sq.mt.)	Tnmt (No.)
Ground Floor	90.58	90.58	90.58	90.58	01
First Floor	90.58	90.58	90.58	90.58	00
Terrace Floor	0.00	0.00	0.00	0.00	00
Total :	181.16	181.16	181.16	181.16	01
Total Number of Same Buildings	1				
Total :	181.16	181.16	181.16	181.16	01

SCHEDULE OF DOOR:

BUILDING NAME	NAME	LENGTH	HEIGHT	NOS
A (SMT PREMA DEVI)	D	0.90	2.10	13

SCHEDULE OF WINDOW/VENTILATION:

BUILDING NAME	NAME	LENGTH	HEIGHT	NOS
A (SMT PREMA DEVI)	V	1.00	1.20	02
A (SMT PREMA DEVI)	W1	1.50	1.20	02
A (SMT PREMA DEVI)	W	2.10	1.20	16

UnitBUA Table for Building :A (SMT PREMA DEVI)

FLOOR	Name	UnitBUA Type	UnitBUA Area	Carpet Area	No. of Rooms	No. of Tenement
GROUND FLOOR PLAN	SPLIT A	FLAT	162.01	154.79	6	1
FIRST FLOOR PLAN	SPLIT A	FLAT	0.00	0.00	6	0
Total:	-	-	162.01	154.79	12	1

LTP NAME AND SIGNATURE	STRUCTURAL ENG'S NAME AND SIGNATURE	BUILDER NAME AND SIGNATURE	DIGITAL SIGNATURE
ANKIT RAJ RNP/ENG/0004/2021			

Proposal Basic Information	
Proposal File No.	RNP/EN/004/W02/2023
Owner Name	SMT PREMA DEVI
Khata No	52
Plot No	780
Village Name	Village
Use	Residential
SubUse	Bungalow/ Dwelling / Non Apartment

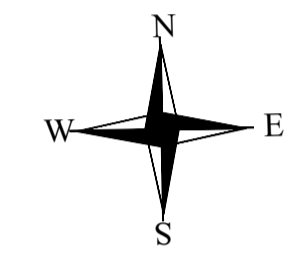
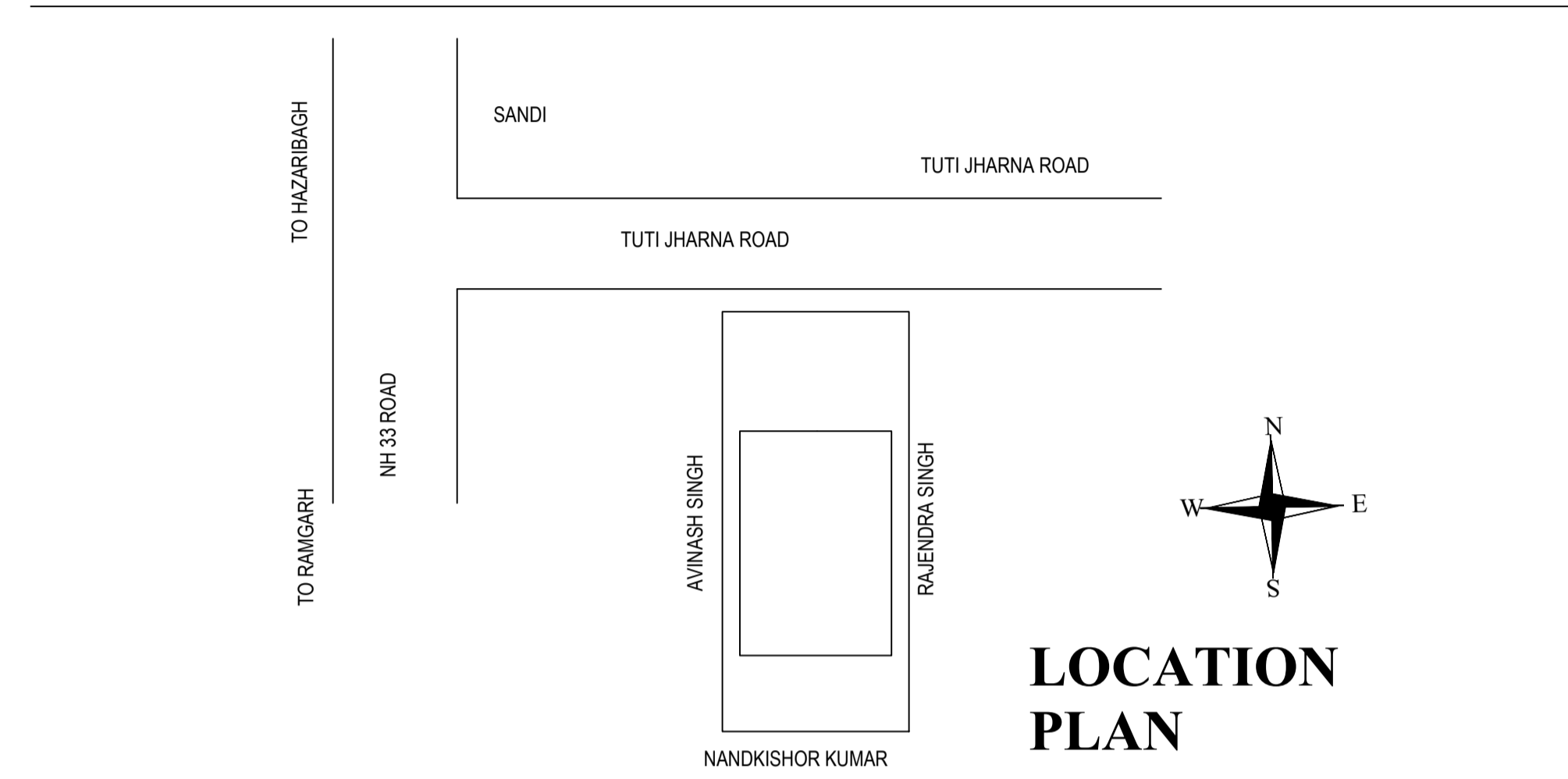

LTP NAME AND SIGNATURE	STRUCTURAL ENG'S NAME AND SIGNATURE	BUILDER NAME AND SIGNATURE	DIGITAL SIGNATURE
ANKIT RAJ RNP/ENG/0004/2021			