

Proposal Basic Information

Proposal File No.	RNP/BP/0077/W27/2023
Owner Name	SMT.REKHA DEVI
Khata No	26
Plot No	2061
Village Name	Village1
Use	Residential
SubUse	Bungalow/ Dwelling / Non Apartment

FAR & Tenement Details (Table 4c-1)

Building	No. of Same Bldg	Total Built Up Area (Sq.mt.)	Proposed FAR Area (Sq.mt.) Resi.	Total FAR Area (Sq.mt.)	Total Consumed Additional FAR Area (Sq.mt.)	Tnmt (No.)
R (BUILDING)	1	99.98	99.98	99.98	99.98	01
Grand Total :	1	99.98	99.98	99.98	99.98	01

AREA STATEMENT RAMGARH NAGAR PARISHAD	VERSION NO. : 1.0.66 VERSION DATE: 16/10/2020
PROJECT DETAIL:	
Region: JHARKHAND URBAN LOCAL BODIES	Plot Use: Residential
District: RAMGARH	Plot SubUse: Bungalow/ Dwelling / Non Apartment
Authority: RAMGARH NAGAR PARISHAD	PlotNearby/ReligiousStructure: NA
Inward No: RNP/BP/0077/W27/2023	Plot/SubPlot No: 2061
Application Type: General Proposal	North: Road Width - 4.26
Project Type: Building Permission	South: Plot No. - SABITA DEVI
Nature of Development: New	East: Road Width - 4.26
Location of Development Area: Old Area	West: Plot No. - LAKHAN SAW
AREA DETAILS:	SQ.MT.
AREA OF PLOT (Minimum)	(A) 185.66
NET AREA OF PLOT(Gross Plot Area - Deduction from Gross Plot area)	(A-Deductions) 185.66
Deduction for Balance Plot Area(from Gross Plot Area)	
Common Plot	15.41
Total	15.41
BALANCE AREA OF PLOT(Net Plot Area - Recreational/Amenity space)	(A-Deductions) 170.24
PLOT AREA FOR COVERAGE(Net Plot Area)	(A-Deductions) 185.66
Plot Area for FAR (Net Plot Area + Road Widening Area)	(A-Deductions) 185.66
COVERAGE CHECK	
Permissible Coverage area (70.00 %)	129.96
Proposed Coverage Area (53.85 %)	99.98
Total Prop. Coverage Area (53.85 %)	99.98
Balance coverage area (16.15 %)	29.98
FAR CHECK	
Perm. FAR Area (1.500)	278.49
Total Perm. FAR area	278.49
Residential FAR	99.98
Proposed FAR Area	99.98
Total Proposed FAR Area	99.98
Consumed FAR (Factor)	0.54
Balance FAR Area	178.51
BUILT UP AREA CHECK	
Total Proposed BuiltUp Area	99.98
ARCHITECT (Regd)	Ismail Ajad
ENGINEER (Regd)	
SUPERVISOR (Regd)	
OWNER (Regd)	SMT.REKHA DEVI
DEVELOPMENT AUTHORITY LOCAL BODY	

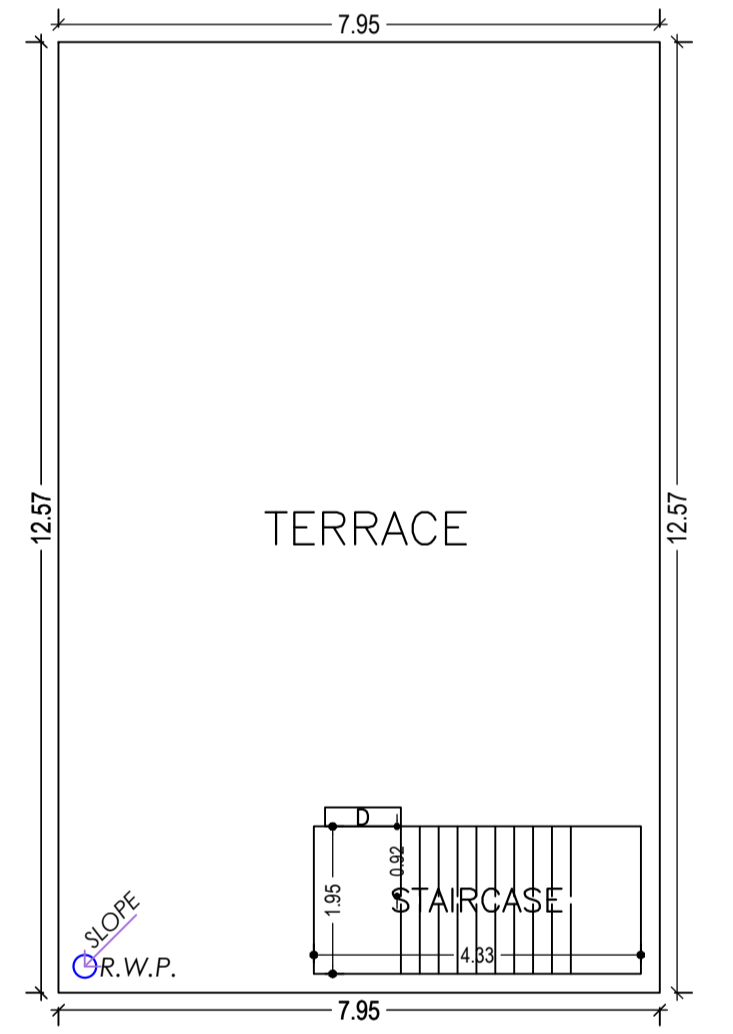
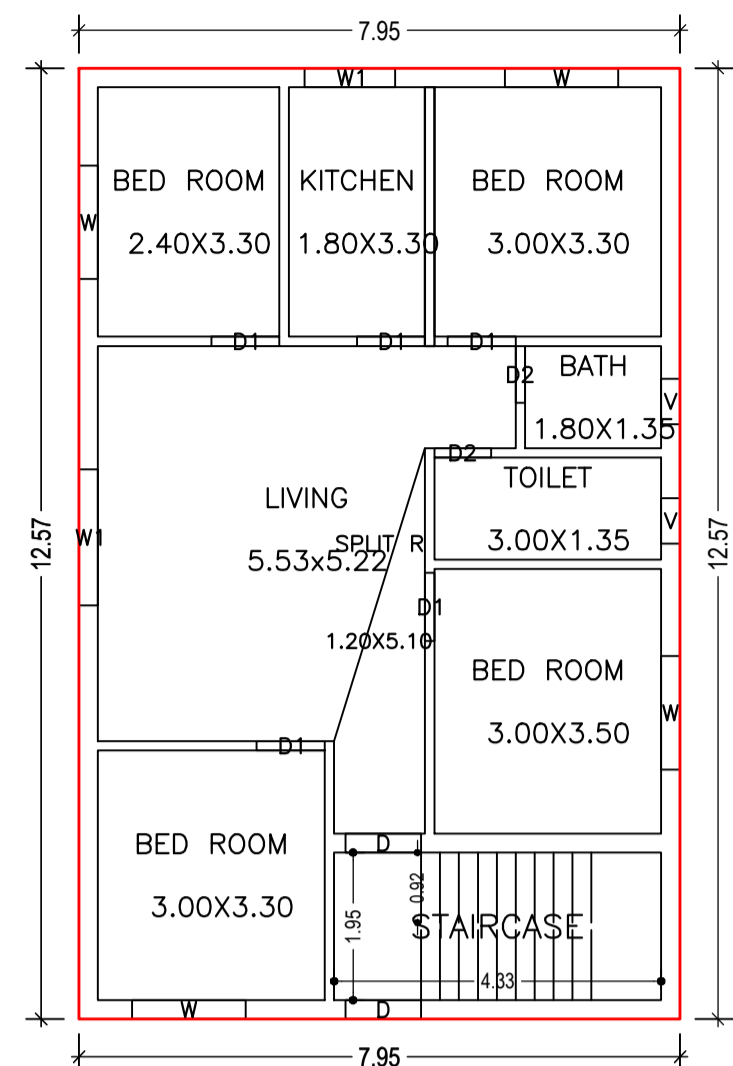
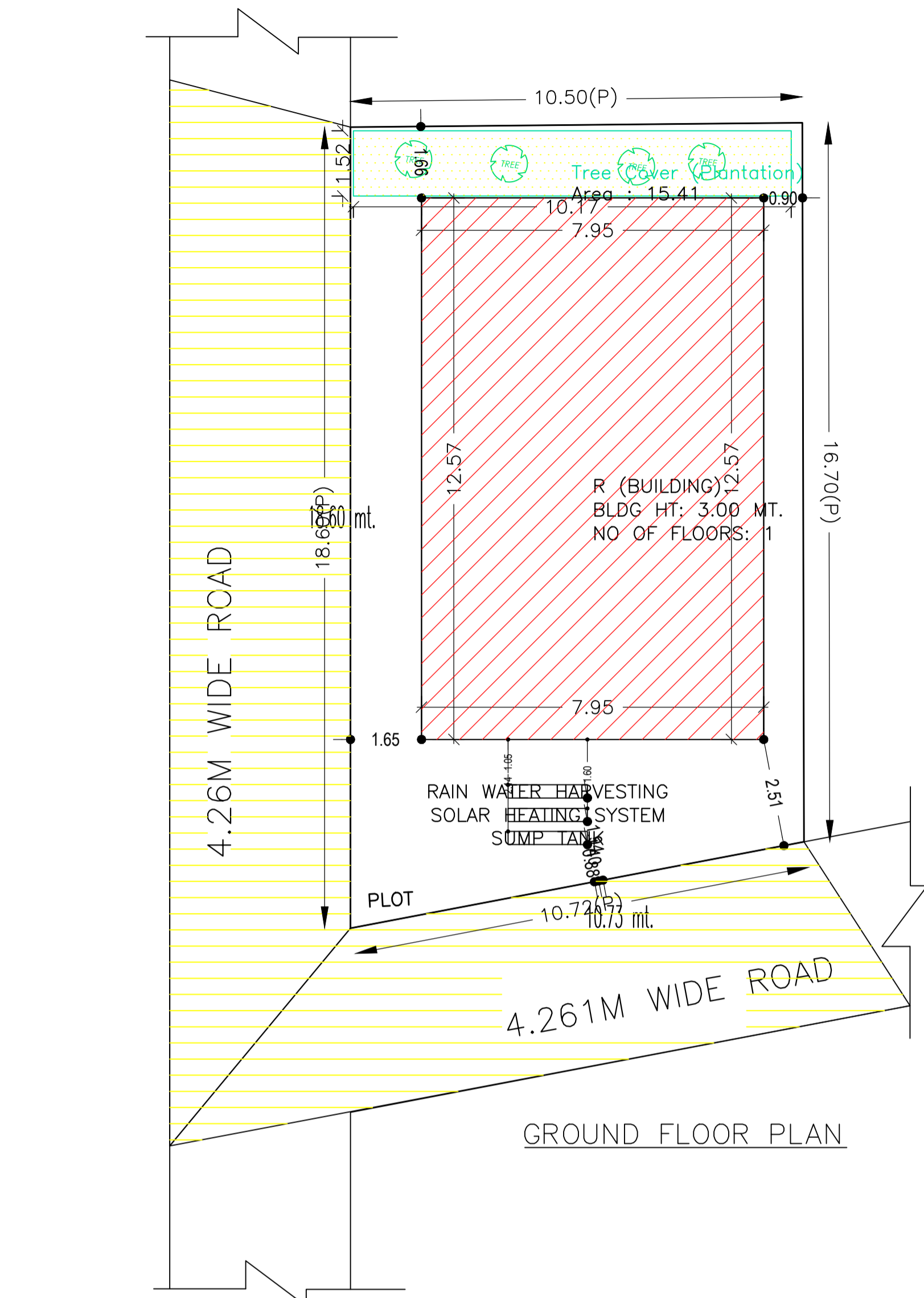
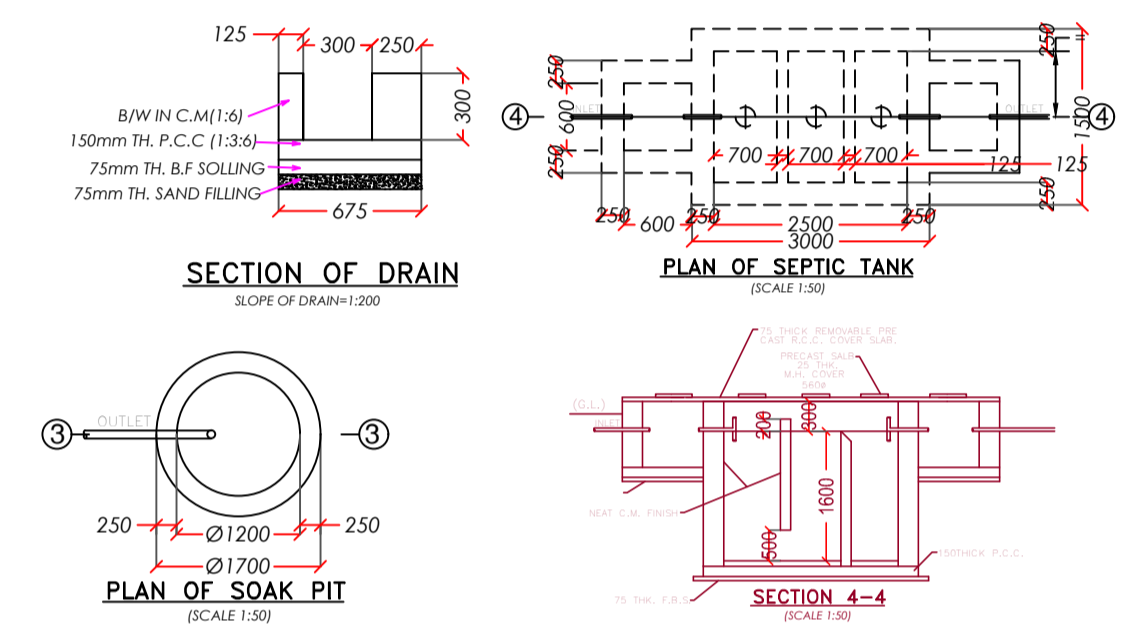
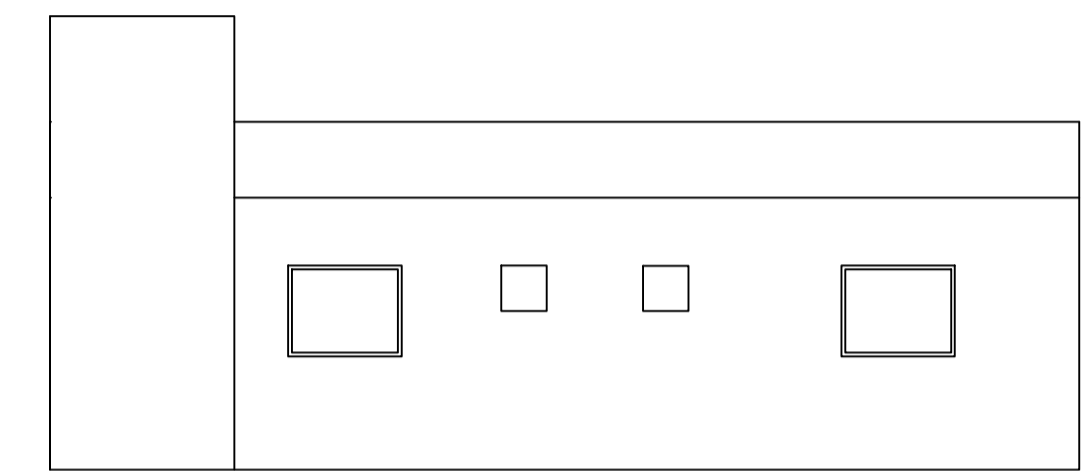

SITE PLAN

COLOR INDEX	
PLOT BOUNDARY	Black
ABUTTING ROAD	Green
PROPOSED CONSTRUCTION	Red
COMMON PLOT	Yellow
ROAD WIDENING AREA	Orange
EXISTING (To be retained)	Blue
EXISTING (To be demolished)	Light Blue

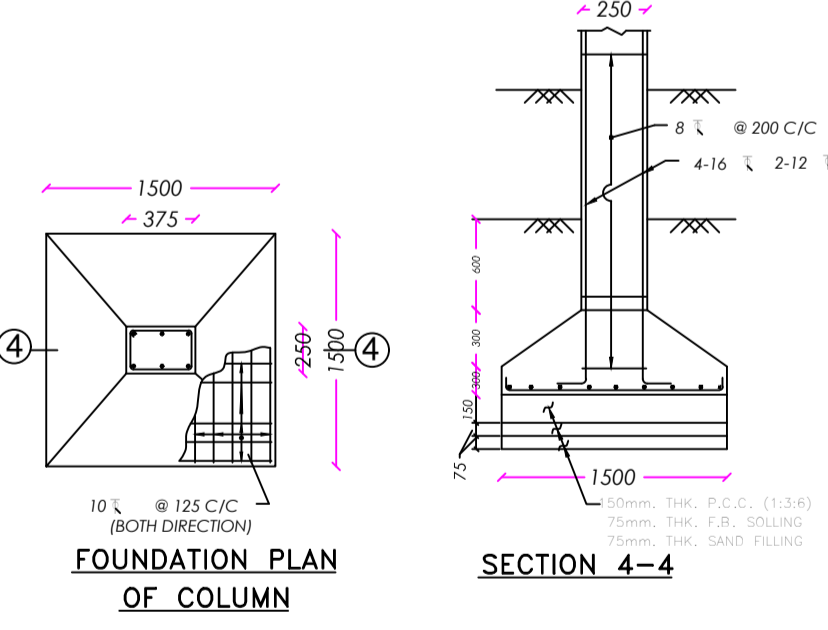

Building :R (BUILDING)

Floor Name	Total Built Up Area (Sq.mt.)	Proposed FAR Area (Sq.mt.) Resi.	Total FAR Area (Sq.mt.)	Total Consumed Additional FAR Area (Sq.mt.)	Tnmt (No.)
Ground Floor	99.98	99.98	99.98	99.98	01
Terrace Floor	0.00	0.00	0.00	0.00	00
Total :	99.98	99.98	99.98	99.98	01
Total Number of Same Buildings	1				
Total :	99.98	99.98	99.98	99.98	01

SCHEDULE OF DOOR:

BUILDING NAME	NAME	LENGTH	HEIGHT	NOS
R (BUILDING)	D2	0.75	2.10	02
R (BUILDING)	D1	0.90	2.10	05
R (BUILDING)	D	1.00	2.10	01

SCHEDULE OF WINDOW/VENTILATION:

BUILDING NAME	NAME	LENGTH	HEIGHT	NOS
R (BUILDING)	V	0.60	0.60	02
R (BUILDING)	W1	1.20	1.20	01
R (BUILDING)	W	1.50	1.20	04
R (BUILDING)	W1	1.80	1.80	01

UnitBUA Table for Building :R (BUILDING)

FLOOR	Name	UnitBUA Type	UnitBUA Area	Carpet Area	No. of Rooms	No. of Tenement
GROUND FLOOR PLAN	SPLIT R	FLAT	89.97	89.54	8	1
Total:	-	-	89.97	89.54	8	1

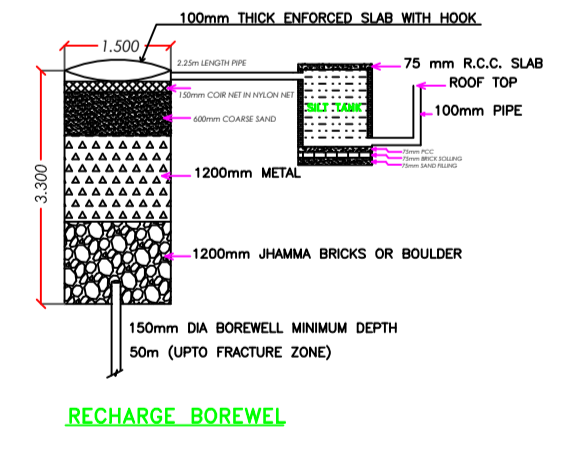

Buildingwise Floor FAR Details

Floor Name	Building Name R (BUILDING)		Total	
	Proposed Built Up Area (Sq.mt.)	Proposed FAR Area (Sq.mt.)	Total Proposed Built Up Area (Sq.mt.)	Total FAR Area (Sq.mt.)
Ground Floor	99.98	99.98	99.98	99.98
Terrace Floor	0.00	0.00	0.00	0.00
Total :	99.98	99.98	99.98	99.98

Building USE/SUBUSE Details

Building Name	Building Use	Building SubUse	Building Structure
R (BUILDING)	Residential	Bungalow/ Dwelling / Non Apartment	Non-Highrise

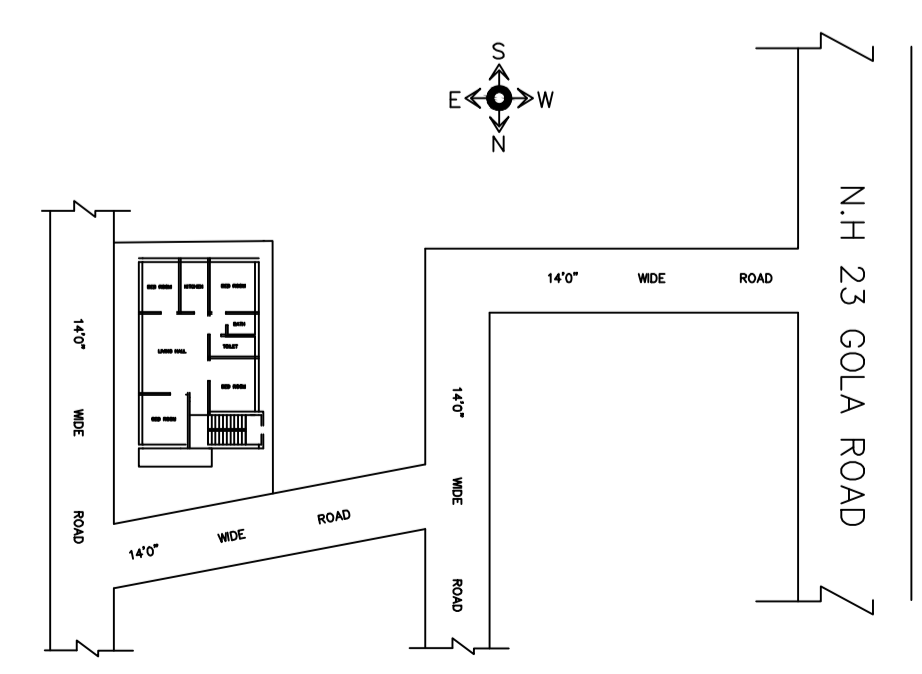

LTP NAME AND SIGNATURE Ismail Ajad RNP/DFTMN/0003/2019	STRUCTURAL ENG'S NAME AND SIGNATURE	BUILDER NAME AND SIGNATURE	DIGITAL SIGNATURE
--	-------------------------------------	----------------------------	-------------------