

SITE PLAN  
SCALE 1:100

SITE PLAN

FAR & Tenement Details (Table 4c-1)

Building	No. of Same Bldg	Total Built Up Area (Sq.mt.)	Deductions (Area in Sq.mt.)		Proposed FAR Area (Sq.mt.)	Total FAR Area (Sq.mt.)	Total Consumed Additional FAR Area (Sq.mt.)	Trmnt (No.)
			Void	Resi.				
A1 (BUILDING)	1	276.12	10.68		265.44	265.44	265.44	02
Grand Total :	1	276.12	10.68		265.44	265.44	265.44	02

Proposal Basic Information

Proposal File No.	SINPC/BP/0034/W04/2018
Owner Name	JAMES SURIN
Khata No	09
Plot No	1143
Village Name	Saldega
Use	Residential
SubUse	Residential Bldg/Apartment

Required Parking (Table 7a)

Building Name	Type	SubUse	Units	Car		Visitors Car		TwoWheeler			
				Reqd.	Prop.	Reqd./Unit	Prop.	Reqd./Unit	Prop.		
A1 (BUILDING)	Residential	Residential Bldg/Apartment	>0	1	2.00	1	2	-	-	-	-
			>0	1	2.00	-	-	-	-	1	2
			>0	1	2.00	-	-	1	1	-	-
Total :			-	-	-	2	2	-	1	2	6

Parking Check (Table 7b)

Vehicle Type	Reqd.		Prop.	
	No.	Area	No.	Area
Car	-	-	2	25.00
Total Car	2	25.00	2	25.00
Visitor's Car Parking	1	12.50	2	25.00
TwoWheeler	2	4.00	6	12.00
Other Parking	-	-	-	146.68
Total		41.50		208.68

AREA STATEMENT SIMDEGA NAGAR PANCHAYAT	VERSION NO: 1.0.27
PROJECT DETAIL:	VERSION DATE: 18/05/2018
Region: JHARKHAND URBAN LOCAL BODIES	Plot Use: Residential
District: SIMDEGA	Plot SubUse: Residential Bldg/Apartment
Authority: SIMDEGA NAGAR PANCHAYAT	PlotNearby/ReligiousStructure: NA
Inward No: SINPC/BP/0034/W04/2018	Plot/SubPlot No: 1143
Application Type: General Proposal	North: -
Project Type: Building Permission	South: -
Nature of Development: New	East: -
Location of Development Area: New Area	West: -
AREA DETAILS:	SQ.MT.
AREA OF PLOT (Minimum)	(A) 505.37
Deduction for NetPlot Area	
Surrender Free of Cost	19.37
Total	19.37
NET AREA OF PLOT(Gross Plot Area - Deduction from Gross Plot area)	(A-Deductions) 486.00
Deduction for Balance Plot Area(from Gross Plot Area)	
Surrender Free of Cost	19.37
Common Plot	110.00
Total	129.36
BALANCE AREA OF PLOT(Net Plot Area - Recreational/Amenity space)	(A-Deductions) 376.00
PLOT AREA FOR COVERAGE(Net Plot Area)	(A-Deductions) 486.00
Plot Area for FAR (Net Plot Area + RoadWidening Area)	(A-Deductions) 505.37
COVERAGE CHECK	
Permissible Coverage area ( 60.00 % )	291.60
Proposed Coverage Area ( 28.41 % )	138.06
Total Prop. Coverage Area ( 28.41 % )	138.06
Balance coverage area ( 31.59 % )	153.54
FAR CHECK	
Perm. FAR Area ( 1.50 )	758.05
Total Perm. FAR area	758.05
Residential FAR	265.44
Proposed FAR Area	265.44
Total Proposed FAR Area	265.44
Consumed FAR (Factor)	0.53
Balance FAR Area	492.61
BUILT UP AREA CHECK	
Total Proposed BuiltUp Area	276.12
ARCHITECT (Regd)	RAJESH KUMAR
ENGINEER (Regd)	
SUPERVISOR (Regd)	
OWNER (Regd)	JAMES SURIN
DEVELOPMENT AUTHORITY	LOCAL BODY

COLOR INDEX	
PLOT BOUNDARY	Black
ABUTTING ROAD	Green
PROPOSED CONSTRUCTION	Red
COMMON PLOT	Yellow
ROAD WIDENING AREA	Blue
EXISTING (To be retained)	Light Blue
EXISTING (To be demolished)	Orange

Buildingwise Floor FAR Details

Floor Name	Building Name A1 (BUILDING)		Total	
	Proposed Built Up Area (Sq.mt.)	Proposed FAR Area (Sq.mt.)	Total Proposed Built Up Area (Sq.mt.)	Total FAR Area (Sq.mt.)
Ground Floor	138.06	132.72	138.06	132.72
First Floor	138.06	132.72	138.06	132.72
Terrace Floor	0.00	0.00	0.00	0.00
Total :	276.12	265.44	276.12	265.44

Building USE/SUBUSE Details

Building Name	Building Use	Building SubUse	Building Structure
A1 (BUILDING)	Residential	Residential Bldg/Apartment	Non-Highrise

LTP NAME AND SIGNATURE RAJESH KUMAR SINPC/DFTMN/0008/2017	STRUCTURAL ENG'S NAME AND SIGNATURE	BUILDER NAME AND SIGNATURE
---	-------------------------------------	----------------------------

Proposal Basic Information	
Proposal File No.	SINPC/BP/0034/W04/2018
Owner Name	JAMES SURIN
Khata No	09
Plot No	1143
Village Name	Saldega
Use	Residential
SubUse	Residential Bldg/Apartment

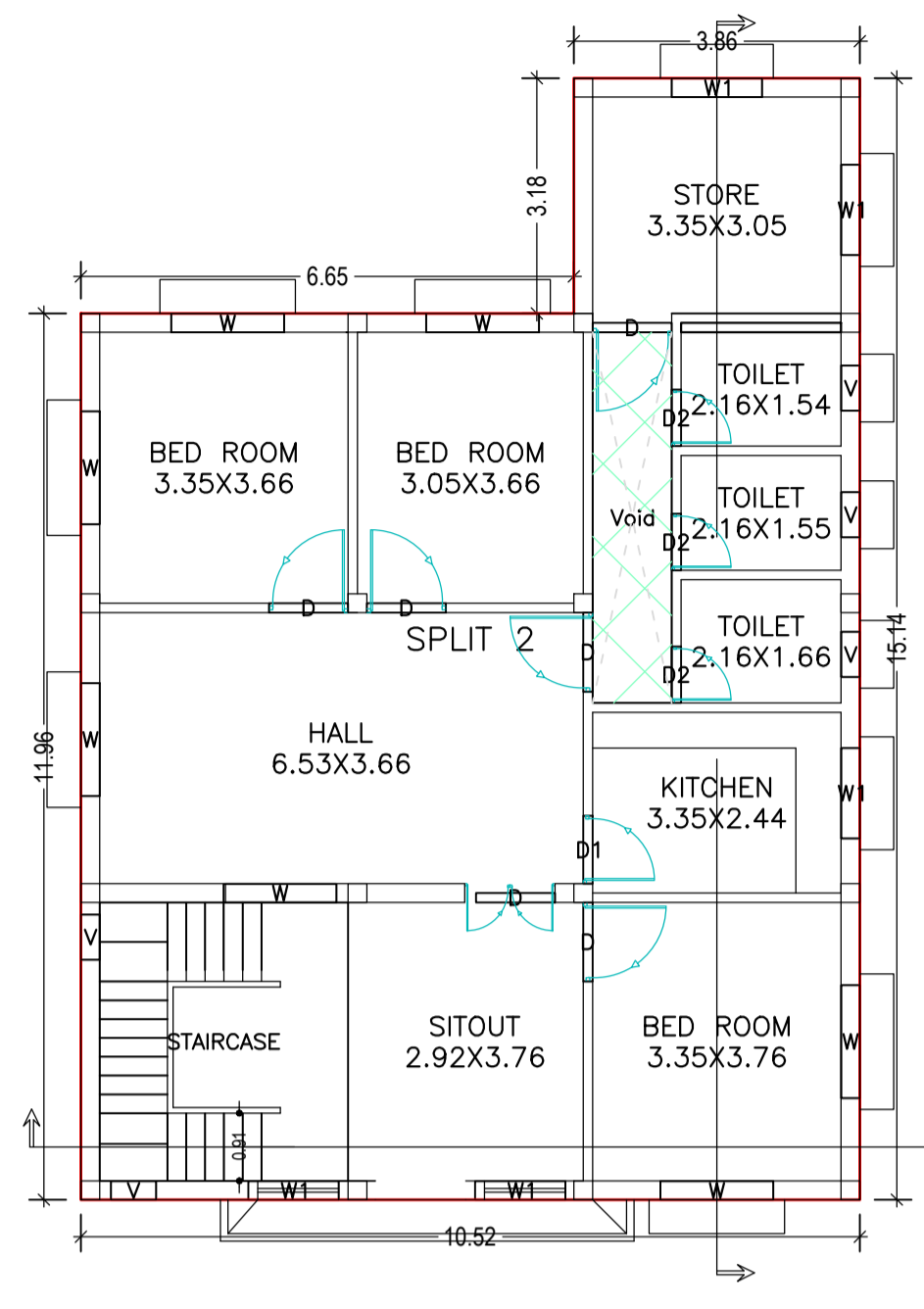
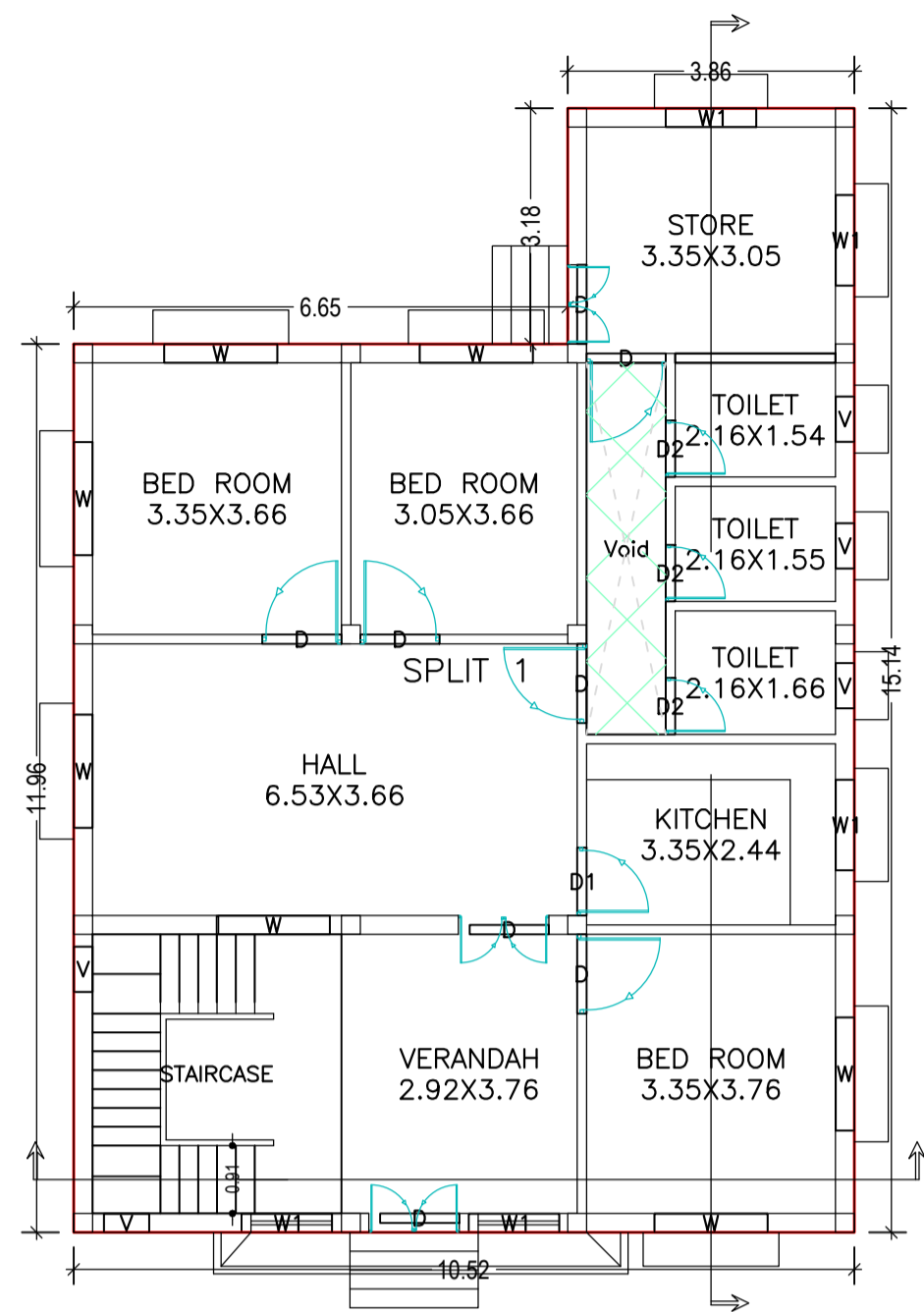

FIRST FLOOR PLAN  
(Proposed)  
(SCALE 1:100)

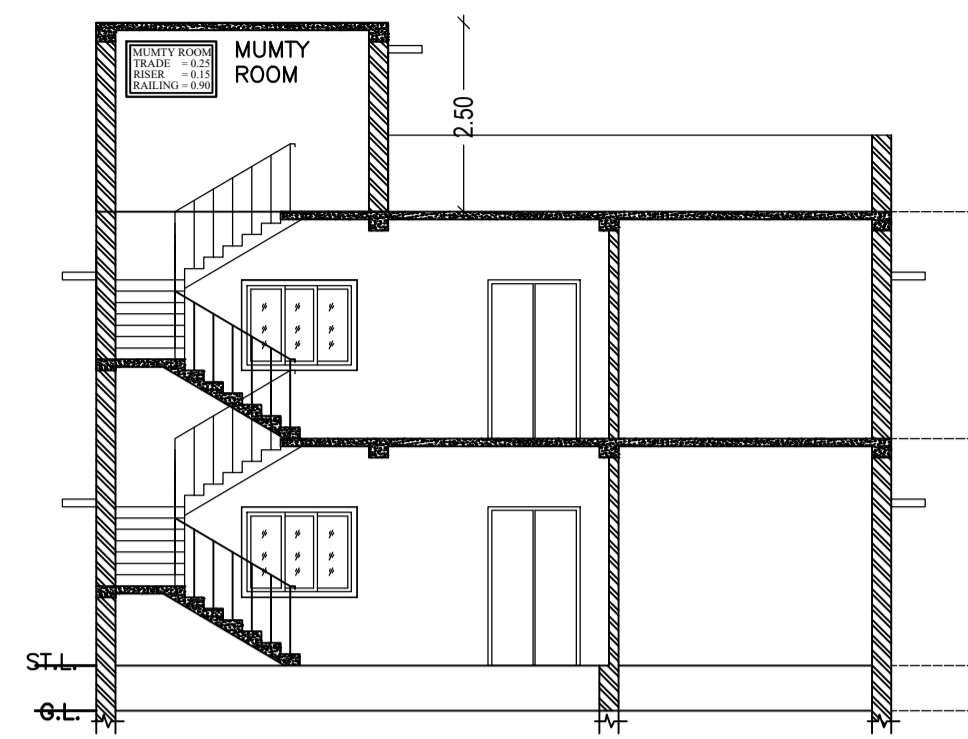

SECTION ON  
SCALE 1:100

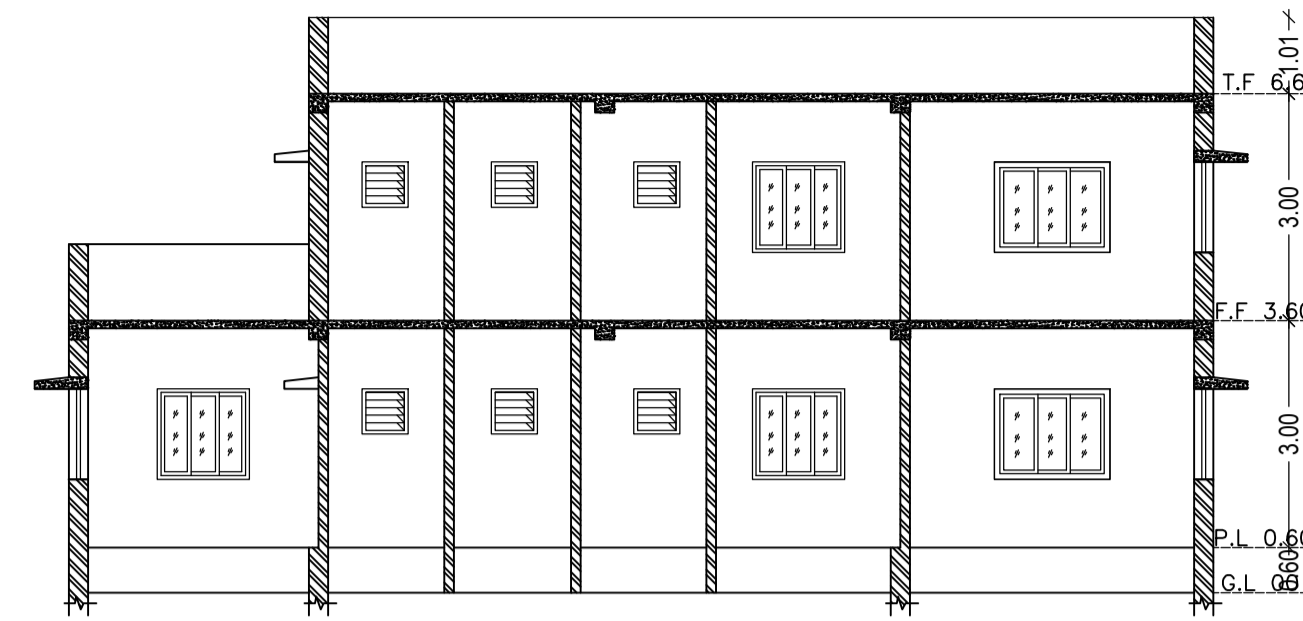

SECTION ON  
SCALE 1:100



FRONT ELEVATION  
SCALE 1:100

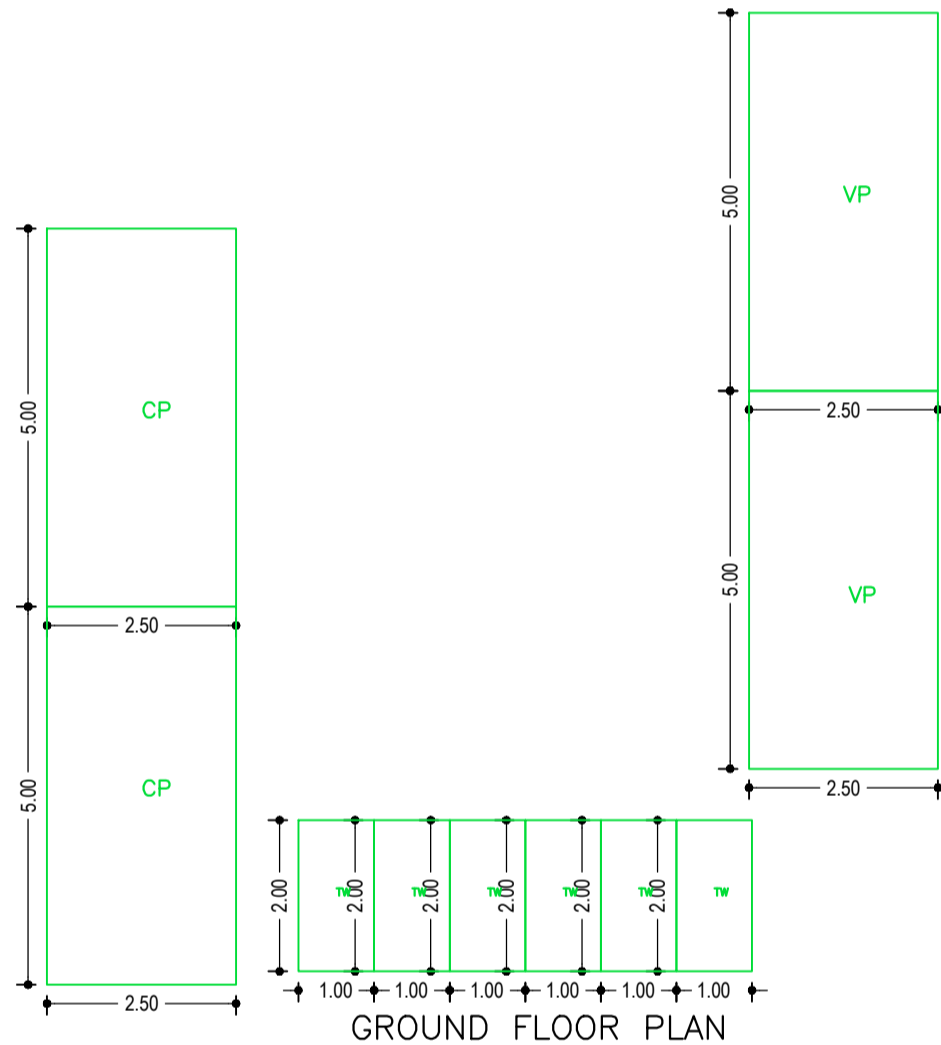

GROUND FLOOR PLAN  
(Proposed)  
(SCALE 1:100)

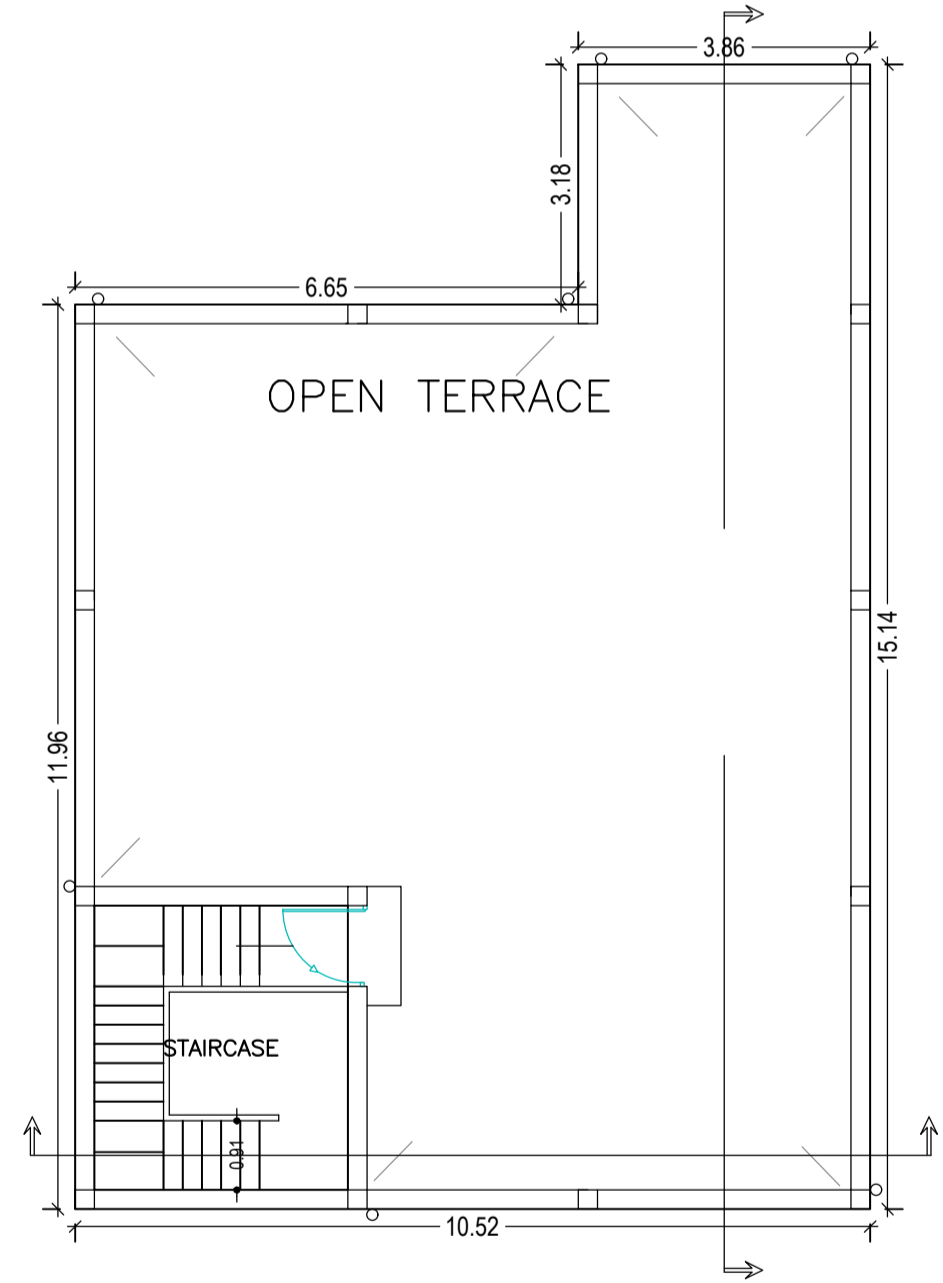

TERRACE FLOOR PLAN  
(SCALE 1:100)

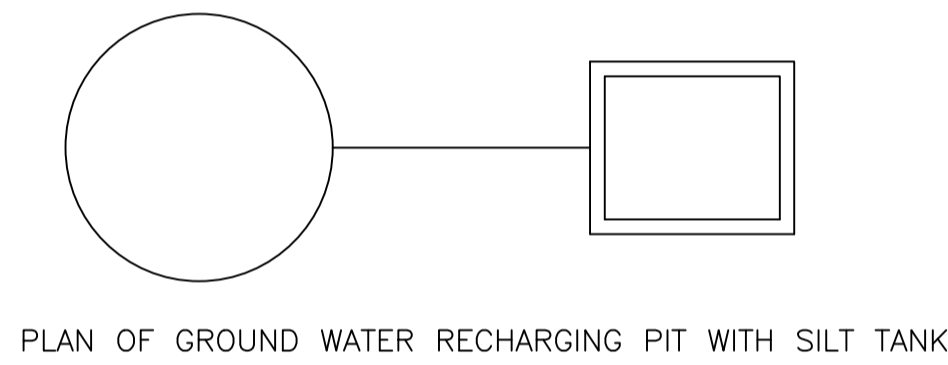

PLAN OF GROUND WATER RECHARGING PIT WITH SILT TANK

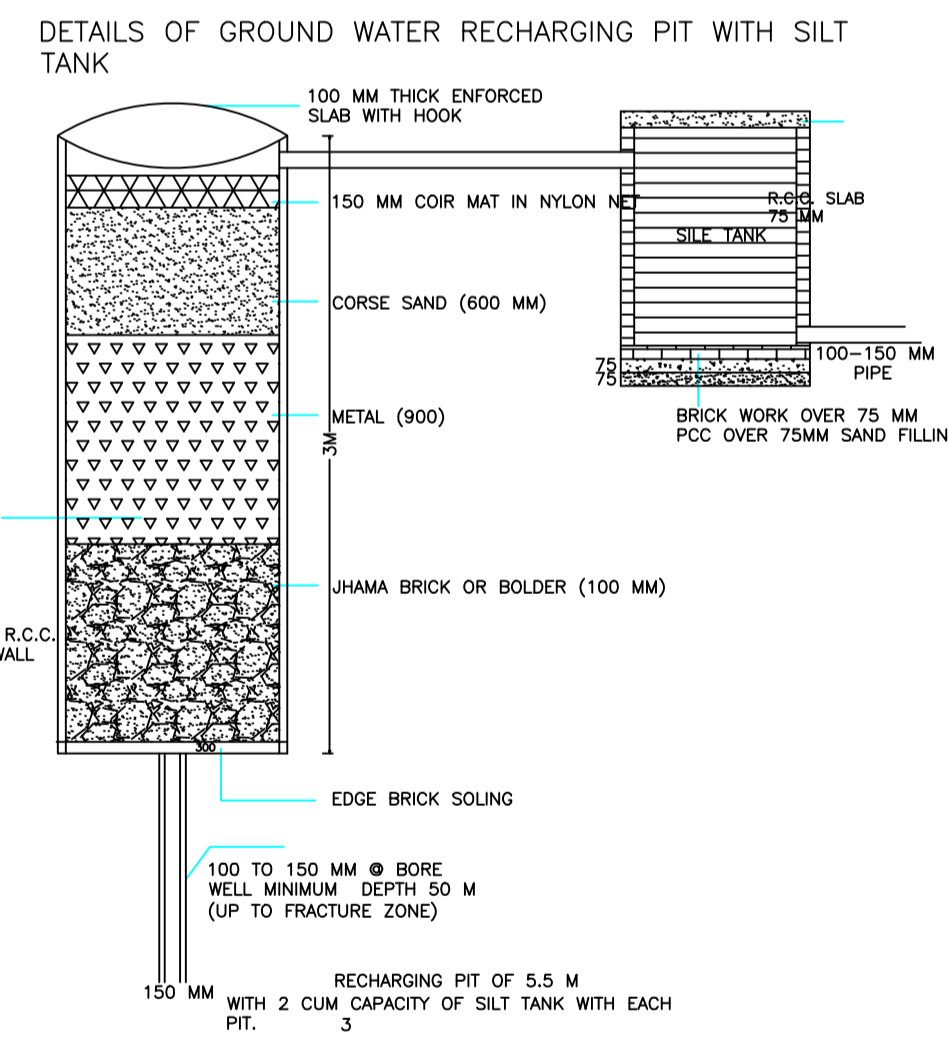

RECHARGING PIT OF 5.5 M WITH 2 CUM CAPACITY OF SILT TANK WITH EACH PIT.

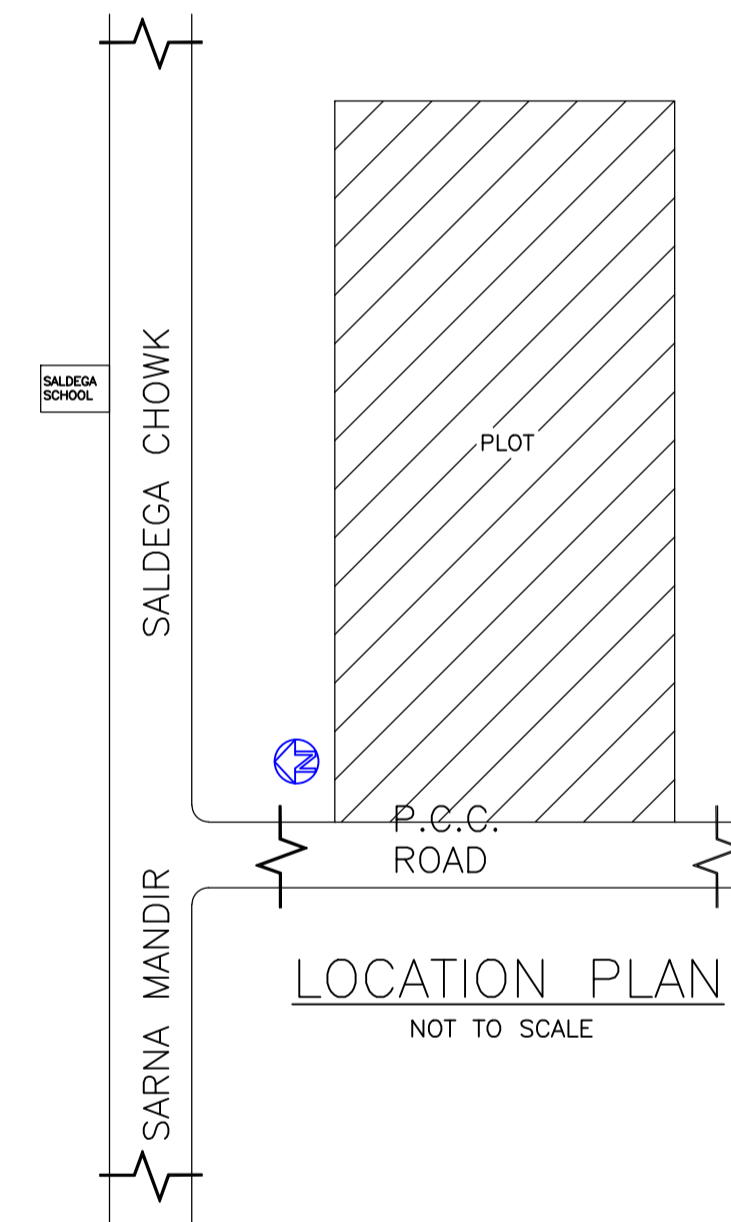

LOCATION PLAN  
NOT TO SCALE

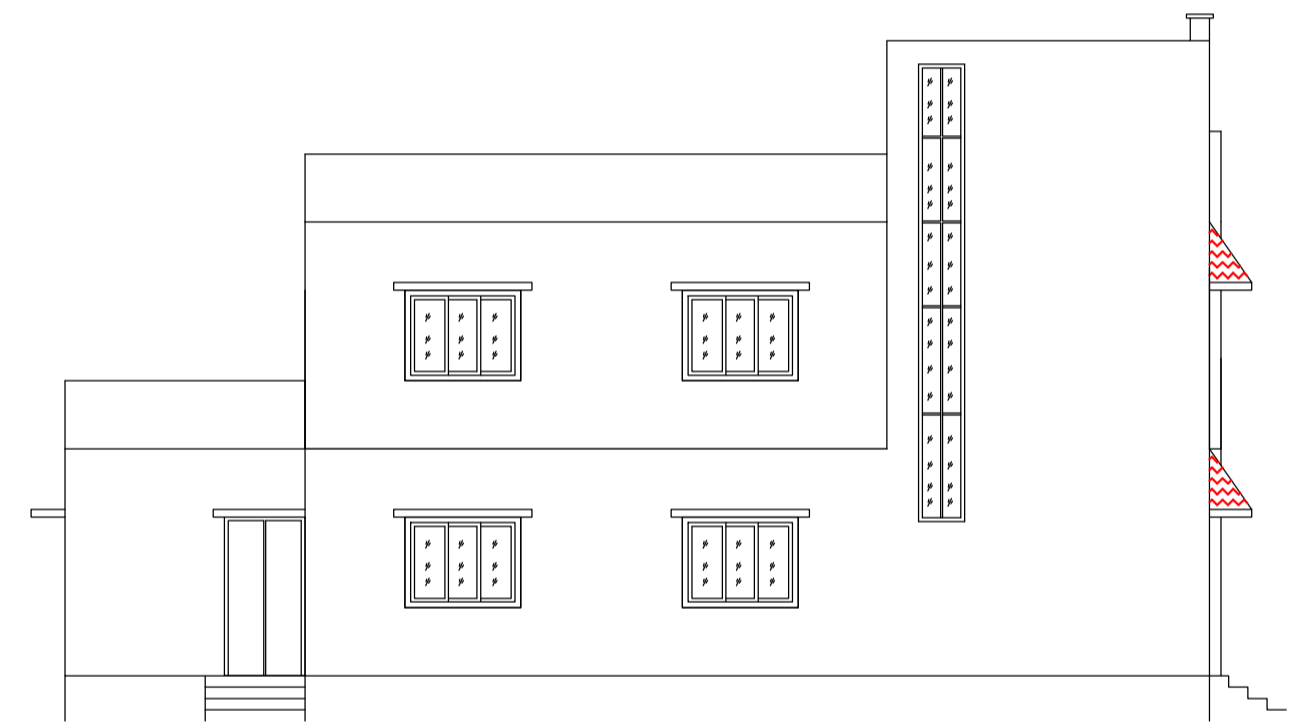

LEFT SIDE ELEVATION  
SCALE 1:100

Building :A1 (BUILDING)

Floor Name	Total Built Up Area (Sq.mt.)	Deductions (Area in Sq.mt.)	Proposed FAR Area (Sq.mt.)	Total FAR Area (Sq.mt.)	Total Consumed Additional FAR Area (Sq.mt.)	Trmt (No.)
Ground Floor	138.06	5.34	132.72	132.72	132.72	01
First Floor	138.06	5.34	132.72	132.72	132.72	01
Terrace Floor	0.00	0.00	0.00	0.00	0.00	00
Total:	276.12	10.68	265.44	265.44	265.44	02
Total Number of Same Buildings	1					
Total:	276.12	10.68	265.44	265.44	265.44	02

SCHEDULE OF DOOR:

BUILDING NAME	NAME	LENGTH	HEIGHT	NOS
A1 (BUILDING)	D2	0.76	2.10	06
A1 (BUILDING)	D1	0.91	2.10	02
A1 (BUILDING)	D	1.07	2.10	14

SCHEDULE OF WINDOW/VENTILATION:

BUILDING NAME	NAME	LENGTH	HEIGHT	NOS
A1 (BUILDING)	V	0.61	1.20	08
A1 (BUILDING)	W1	1.22	1.20	08
A1 (BUILDING)	W	1.52	1.20	14

UnitBUA Table for Building :A1 (BUILDING)

FLOOR	Name	UnitBUA Type	UnitBUA Area	Carpet Area	No. of Rooms	No. of Tenement
GROUND FLOOR PLAN	SPLIT 1	FLAT	105.47	105.20	10	1
FIRST FLOOR PLAN	SPLIT 2	FLAT	105.47	105.20	10	1
Total:	-	-	210.94	210.40	20	2

LTP NAME AND SIGNATURE	STRUCTURAL ENG'S NAME AND SIGNATURE	BUILDER NAME AND SIGNATURE
RAJESH KUMAR SINPC/DFTMN/0008/2017		

Proposal Basic Information

Proposal File No.	SINPCBP/0034/W04/2018
Owner Name	JAMES SURIN
Khata No	09
Plot No	1143
Village Name	Saldega
Use	Residential
SubUse	Residential Bldg/Apartment

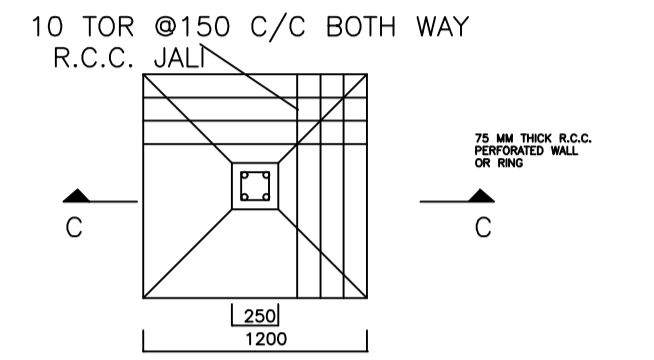

PLAN  
SCALE:-  
1:50

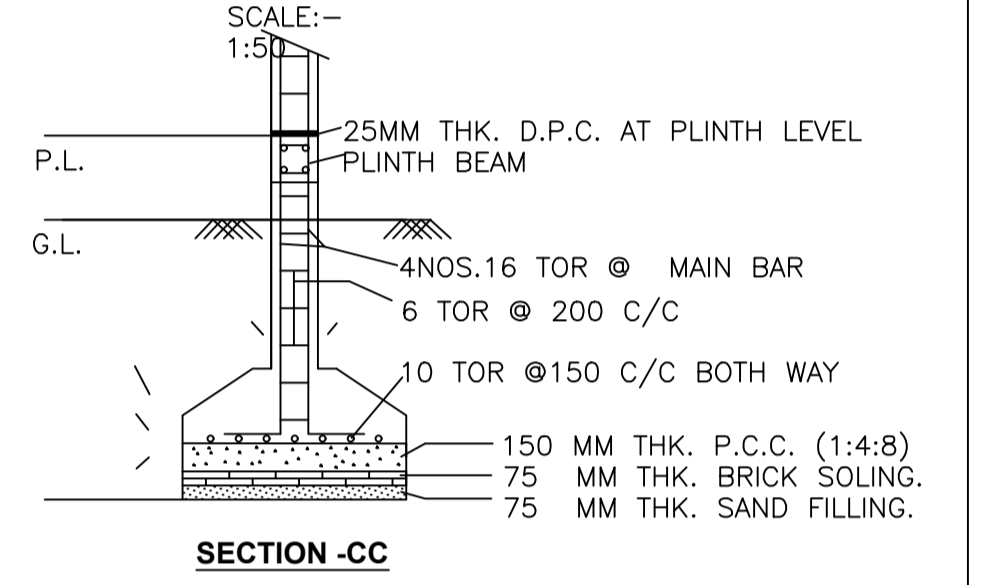

SECTION -CC

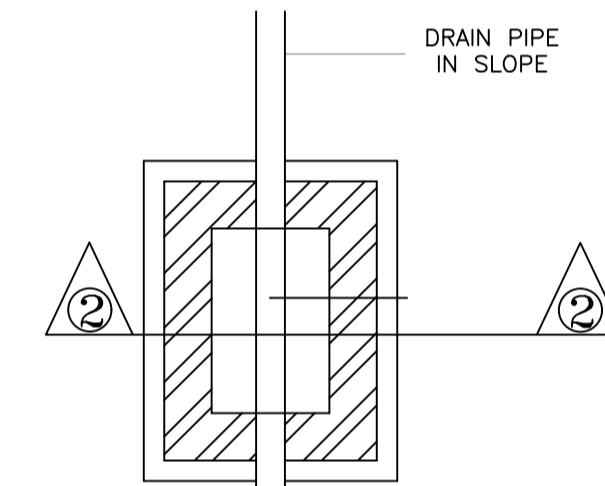

PLAN  
I.C.DETAILS  
R.C.C. COVER

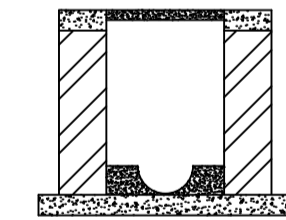

DEPTH VARIES AS PER SLOPE

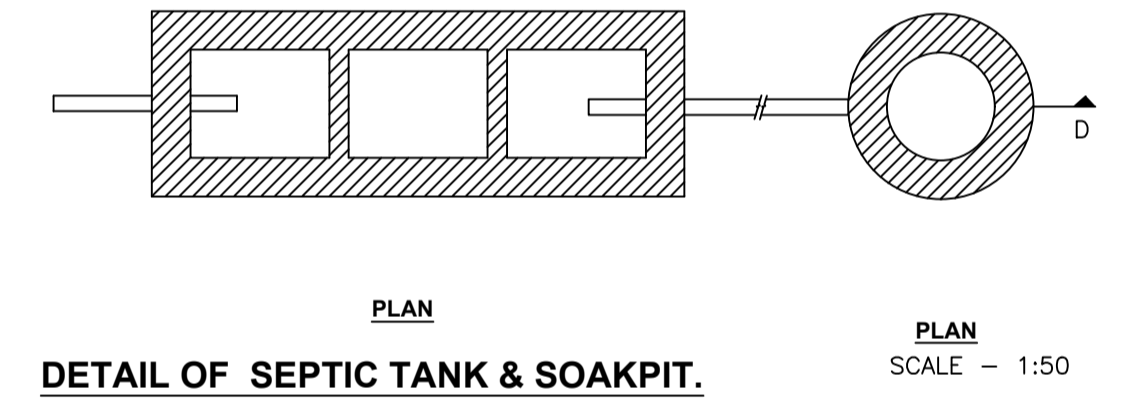

PLAN  
DETAIL OF SEPTIC TANK & SOAKPIT.  
SCALE - 1:50

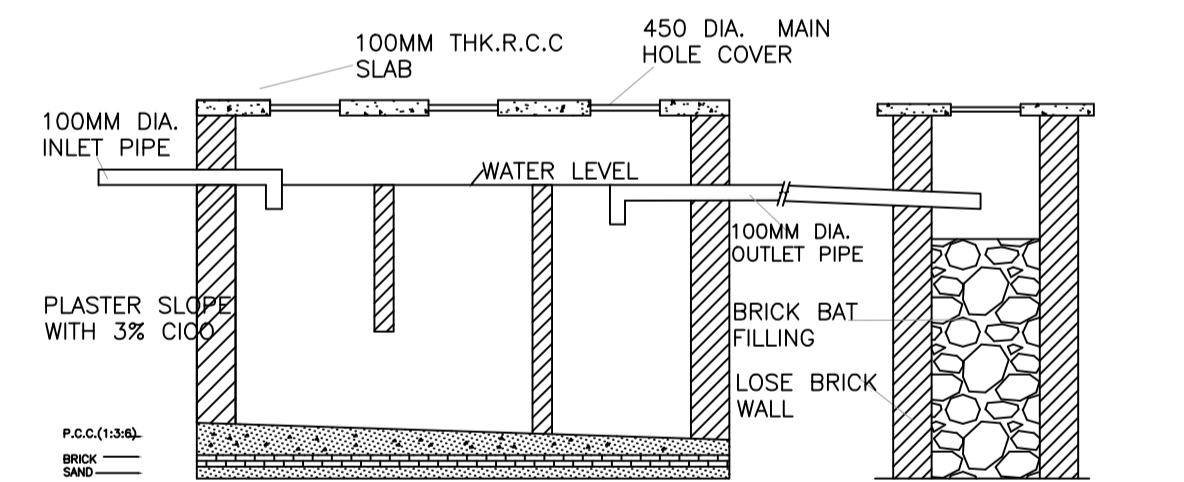

LTP NAME AND SIGNATURE	STRUCTURAL ENG'S NAME AND SIGNATURE	BUILDER NAME AND SIGNATURE
RAJESH KUMAR SINPC/DFTMN/0008/2017		