

SITE PLAN
SCALE 1:100

SITE PLAN

FAR & Tenement Details (Table 4c-1)

Building	No. of Same Bldg	Total Built Up Area (Sq.mt.)	Deductions (Area in Sq.mt.)		Proposed FAR Area (Sq.mt.)	Total FAR Area (Sq.mt.)	Total Consumed Additional FAR Area (Sq.mt.)	Trmnt (No.)
			Void	Resi.				
A1 (BUILDING)	1	237.75	9.18		228.57	228.57	228.57	02
Grand Total :	1	237.75	9.18		228.57	228.57	228.57	02

Proposal Basic Information

Proposal File No.	SINPC/BP/0030/W06/2018
Owner Name	SUNITA TETE
Khata No	152
Plot No	2170
Village Name	Khijri
Use	Residential
SubUse	Residential Bldg/Apartment

Required Parking (Table 7a)

Building Name	Type	SubUse	Area (Sq.mt.)	Units		Car		Visitors Car		TwoWheeler	
				Regd.	Prop.	Regd./Unit	Prop.	Regd./Unit	Prop.	Regd./Unit	Prop.
A1 (BUILDING)	Residential	Residential Bldg/Apartment	> 0	1	2.00	1	2	-	-	-	-
			> 0	1	2.00	-	-	-	-	1	2
			> 0	1	2.00	-	-	1	1	-	-
Total :			-	-	-	-	2	2	-	1	2

Parking Check (Table 7b)

Vehicle Type	Reqd.		Prop.	
	No.	Area	No.	Area
Car	-	-	2	25.00
Total Car	2	25.00	2	25.00
Visitor's Car Parking	1	12.50	2	25.00
TwoWheeler	2	4.00	6	12.00
Other Parking	-	-	-	26.43
Total		41.50		88.43

AREA STATEMENT SIMDEGA NAGAR PANCHAYAT	VERSION NO : 1.0.27
PROJECT DETAIL	VERSION DATE : 18/05/2018
Region: JHARKHAND URBAN LOCAL BODIES	Plot Use: Residential
District: SIMDEGA	Plot SubUse: Residential Bldg/Apartment
Authority: SIMDEGA NAGAR PANCHAYAT	PlotNearbyReligiousStructure: NA
Inward No: SINPC/BP/0030/W06/2018	PlotSubPlot No: 2170
Application Type: General Proposal	North: -
Project Type: Building Permission	South: -
Nature of Development: New	East: -
Location of Development Area: New Area	West: -
AREA DETAILS:	SQ.MT.
AREA OF PLOT (Minimum)	(A) 242.56
Deduction for NetPlot Area	
Surrender Free of Cost	19.03
Total	19.03
NET AREA OF PLOT(Gross Plot Area - Deduction from Gross Plot area)	(A-Deductions) 223.53
Deduction for Balance Plot Area(from Gross Plot Area)	
Surrender Free of Cost	19.03
Common Plot	33.51
Total	52.53
BALANCE AREA OF PLOT(Net Plot Area - Recreational/Amenity space)	(A-Deductions) 190.03
PLOT AREA FOR COVERAGE(Net Plot Area)	(A-Deductions) 223.53
Plot Area for FAR (Net Plot Area + Road Widening Area)	(A-Deductions) 242.56
COVERAGE CHECK	
Permissible Coverage area (70.00 %)	156.47
Proposed Coverage Area (53.18 %)	118.88
Total Prop. Coverage Area (53.18 %)	118.88
Balance coverage area (16.82 %)	37.59
FAR CHECK	
Perm. FAR Area (1.50)	363.84
Total Perm. FAR area	363.84
Residential FAR	228.58
Proposed FAR Area	228.58
Total Proposed FAR Area	228.58
Consumed FAR (Factor)	0.94
Balance FAR Area	135.26
BUILT UP AREA CHECK	
Total Proposed BuiltUp Area	237.75
ARCHITECT (Regd)	RAJESH KUMAR
ENGINEER (Regd)	
SUPERVISOR (Regd)	
OWNER (Regd)	SUNITA TETE
DEVELOPMENT AUTHORITY	LOCAL BODY

COLOR INDEX	
PLOT BOUNDARY	Black
ABUTTING ROAD	Green
PROPOSED CONSTRUCTION	Red
COMMON PLOT	Yellow
ROAD WIDENING AREA	Orange
EXISTING (To be retained)	Blue
EXISTING (To be demolished)	Light Blue

Buildingwise Floor FAR Details

Floor Name	Building Name A1 (BUILDING)		Total	
	Proposed Built Up Area (Sq.mt.)	Proposed FAR Area (Sq.mt.)	Total Proposed Built Up Area (Sq.mt.)	Total FAR Area (Sq.mt.)
Ground Floor	118.88	114.29	118.88	114.29
First Floor	118.87	114.28	118.87	114.28
Terrace Floor	0.00	0.00	0.00	0.00
Total :	237.75	228.57	237.75	228.57

Building USE/SUBUSE Details

Building Name	Building Use	Building SubUse	Building Structure
A1 (BUILDING)	Residential	Residential Bldg/Apartment	Non-Highrise

LTP NAME AND SIGNATURE	STRUCTURAL ENG'S NAME AND SIGNATURE	BUILDER NAME AND SIGNATURE
RAJESH KUMAR SINPC/DFTMN/0006/2017		

Proposal Basic Information	
Proposal File No.	SINPC/BI/0030/W06/2018
Owner Name	SUNITA TETE
Khata No	152
Plot No	2170
Village Name	Khijri
Use	Residential
SubUse	Residential Bldg/Apartment

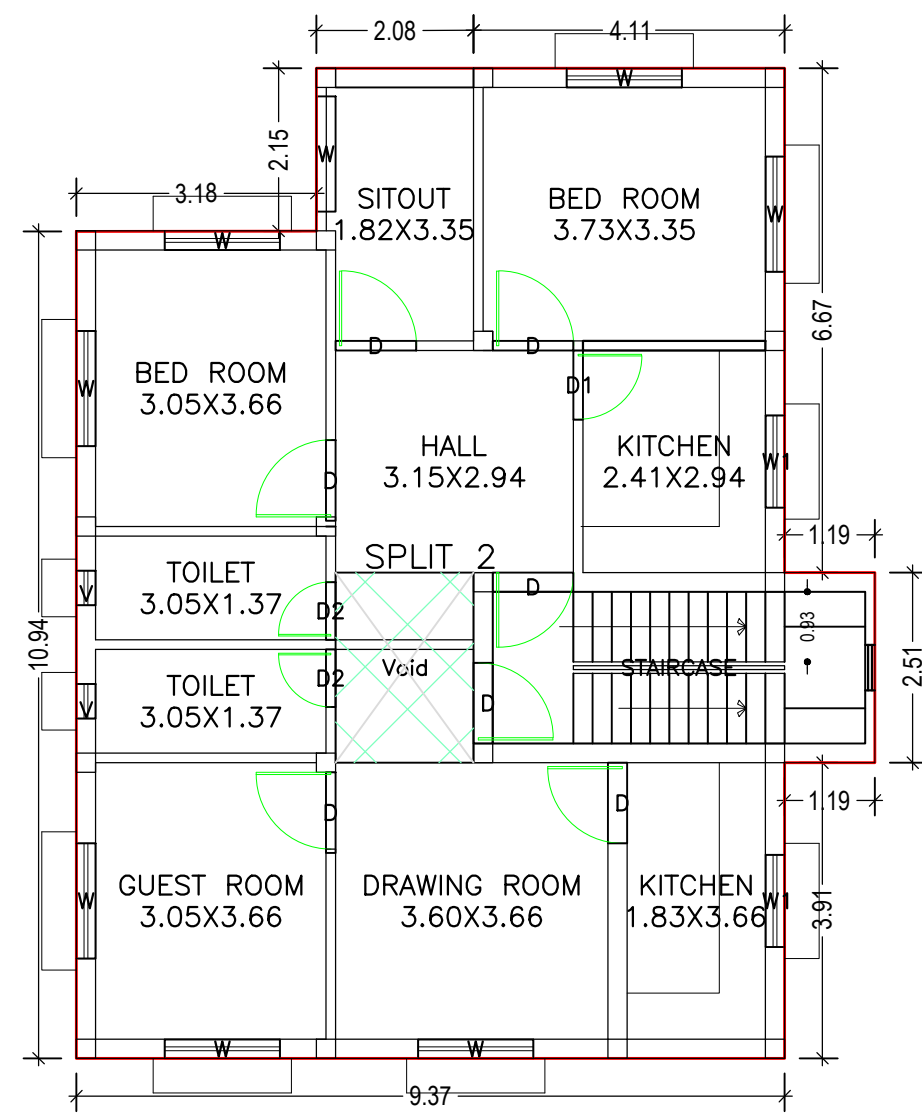
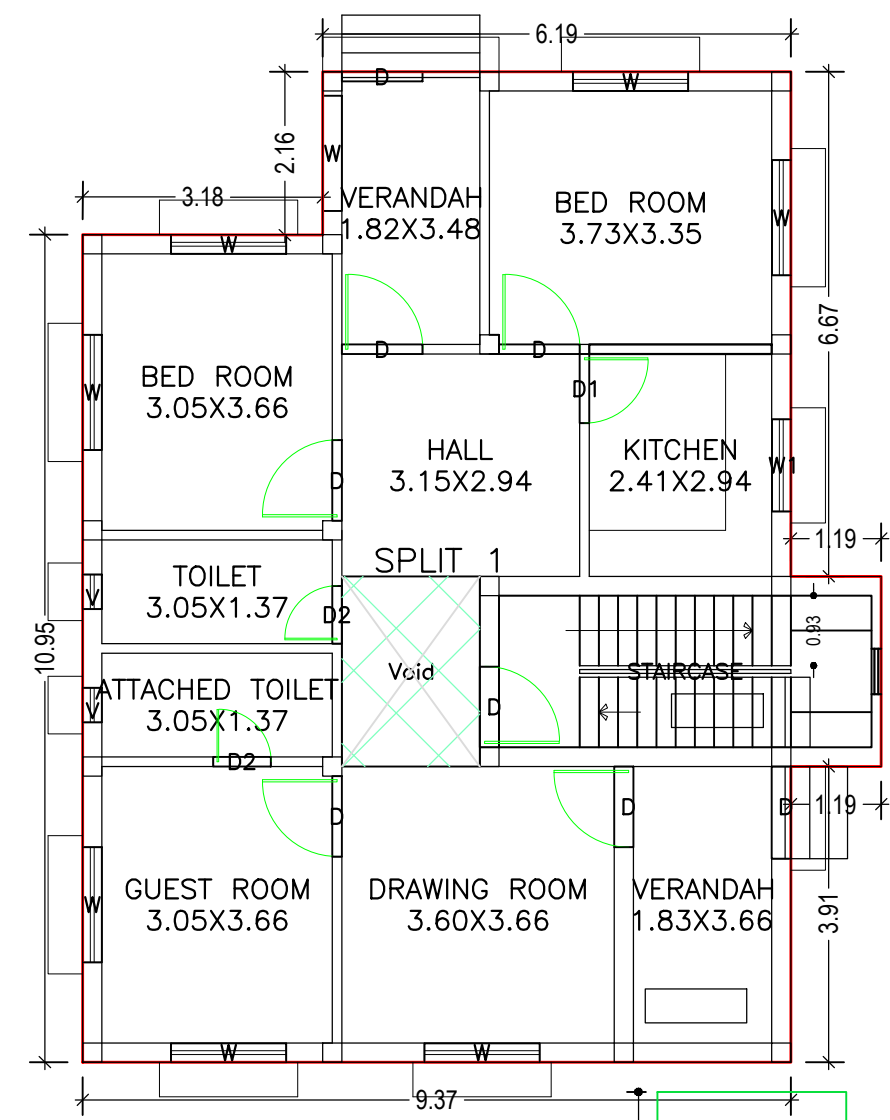

FIRST FLOOR PLAN (Proposed) (SCALE 1:100)

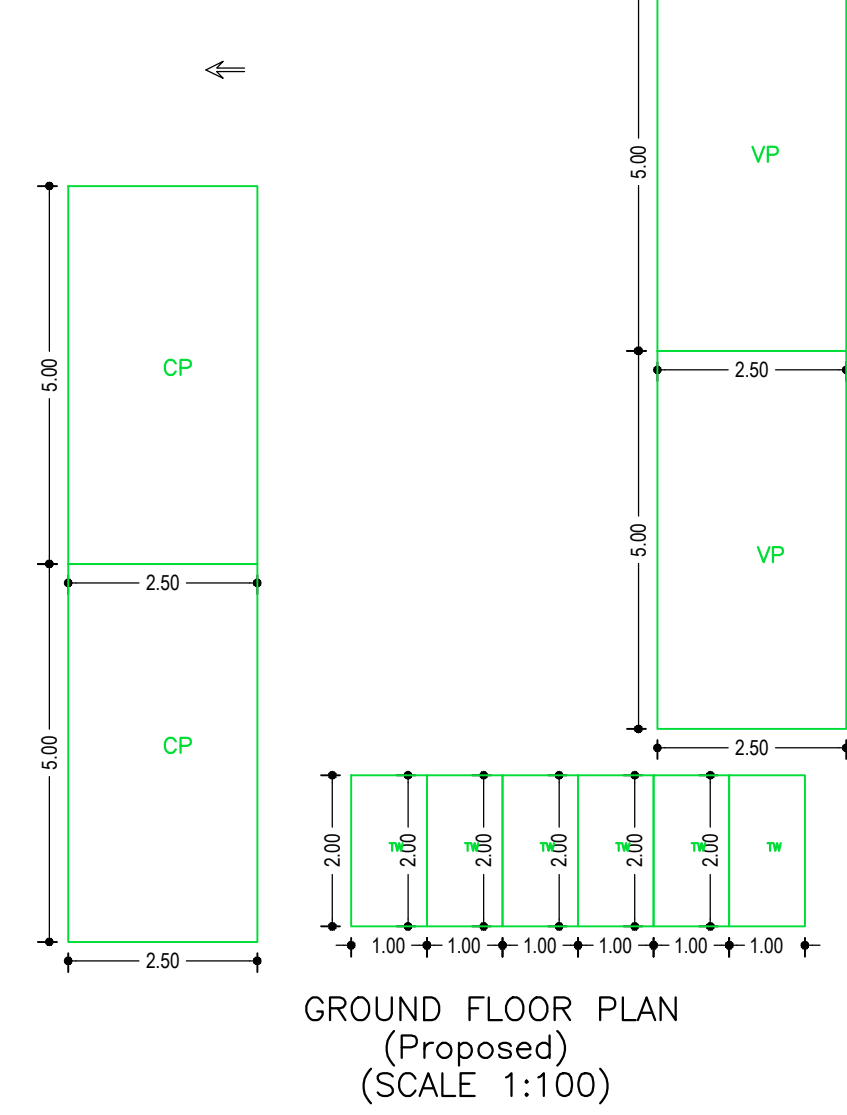

GROUND FLOOR PLAN (Proposed) (SCALE 1:100)

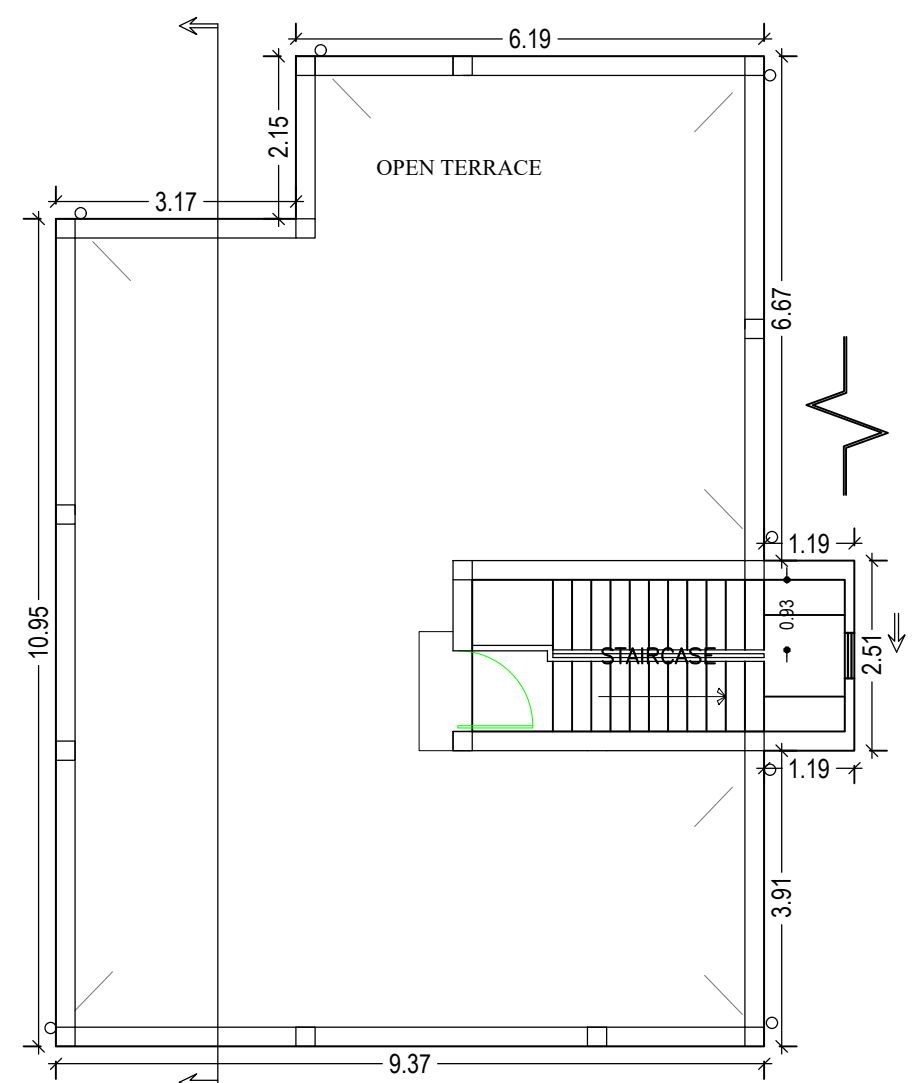

TERRACE FLOOR PLAN (SCALE 1:100)

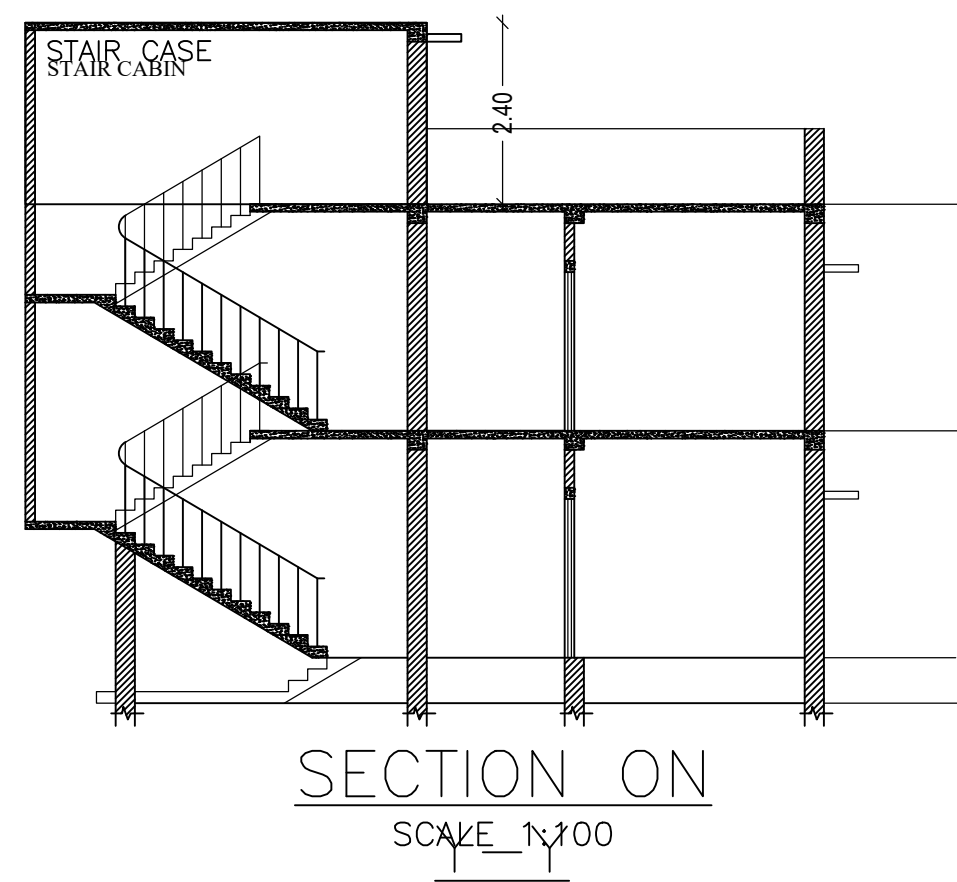

SECTION ON SCALE 1:100

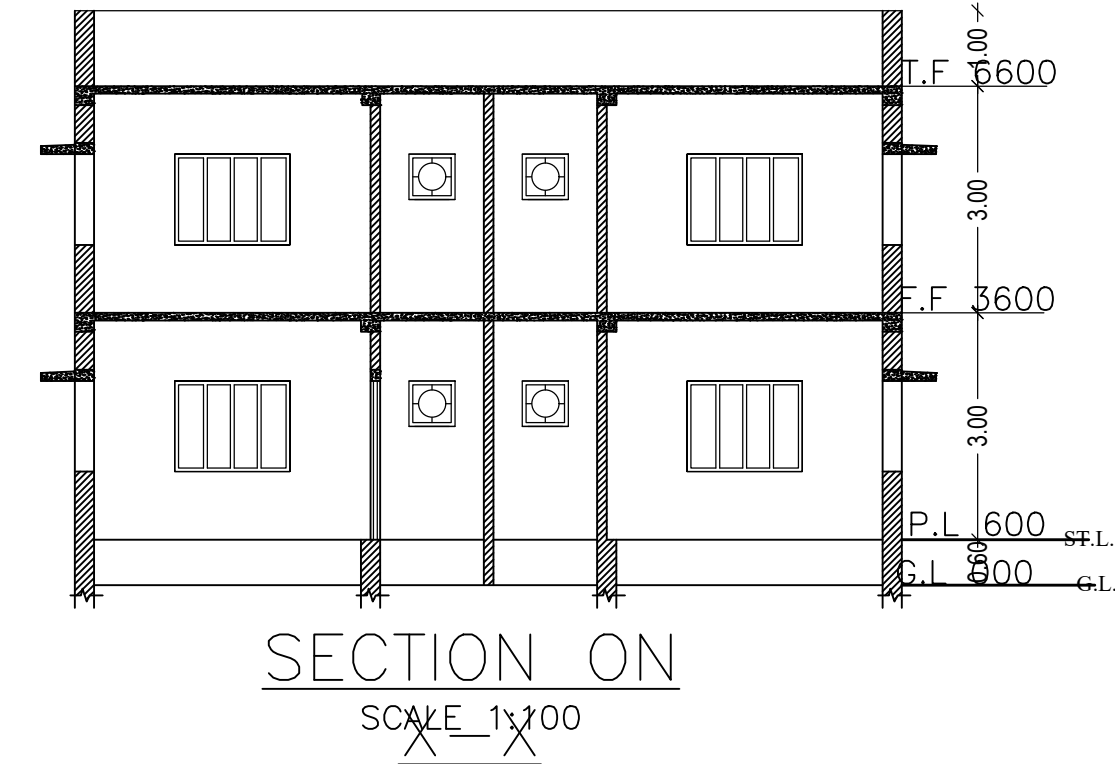

SECTION ON SCALE 1:100

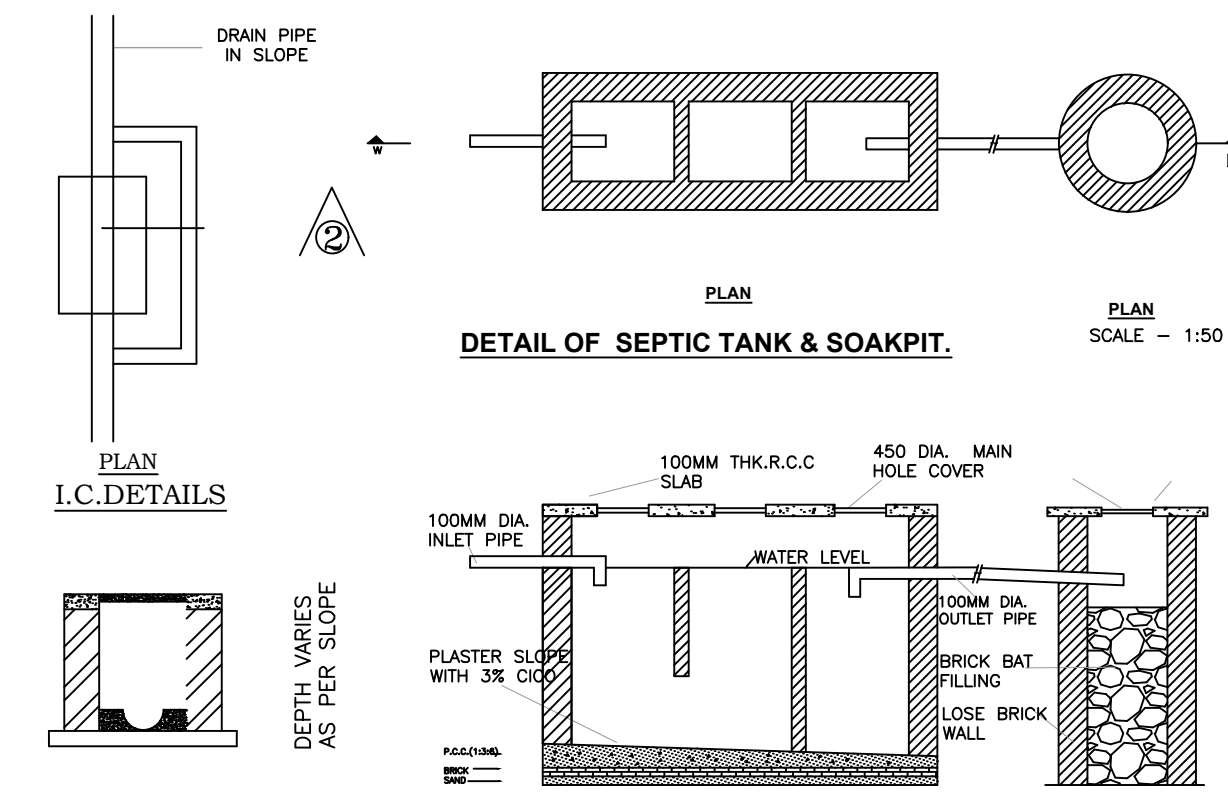

DETAIL OF SEPTIC TANK & SOAKPIT.

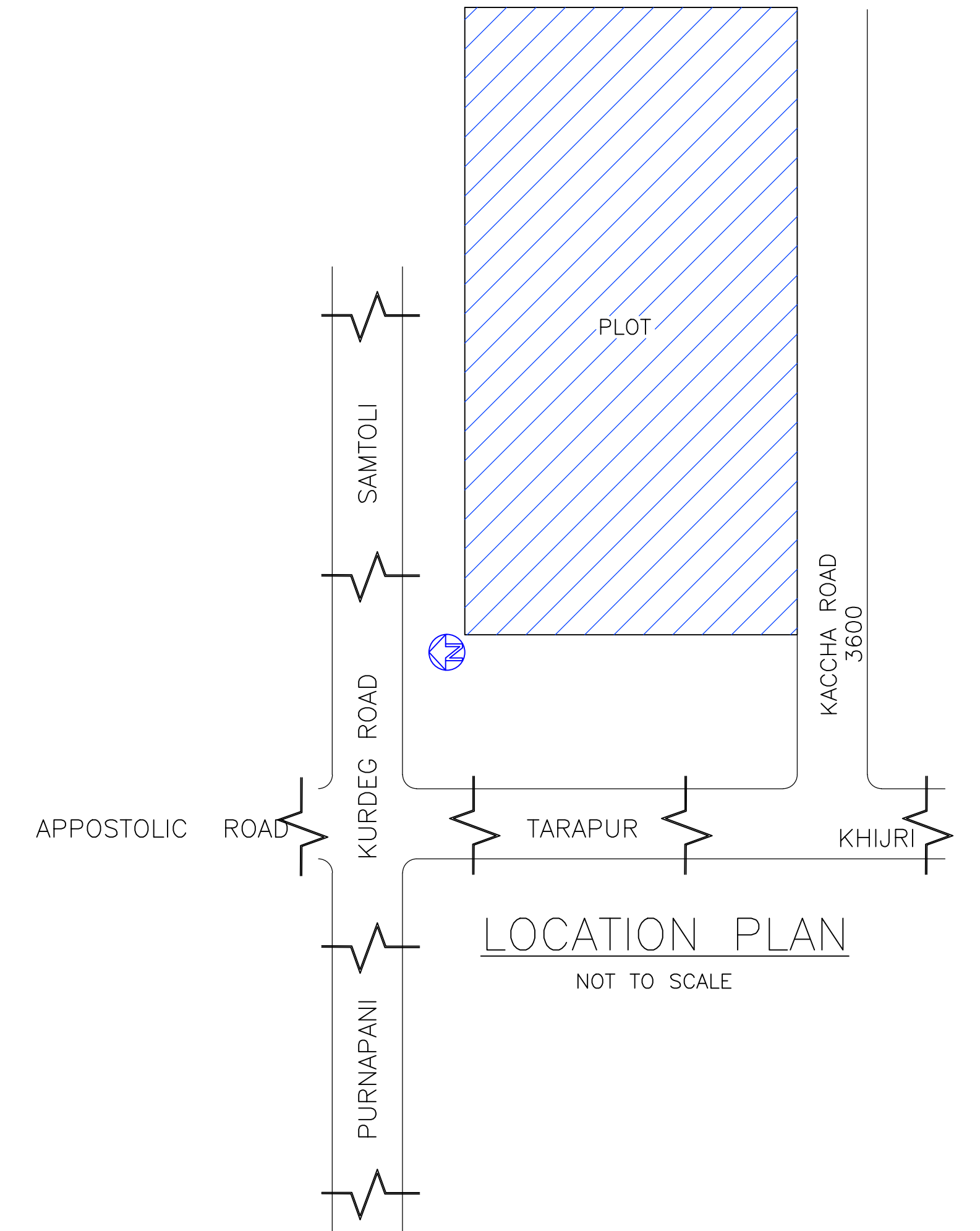

LOCATION PLAN NOT TO SCALE

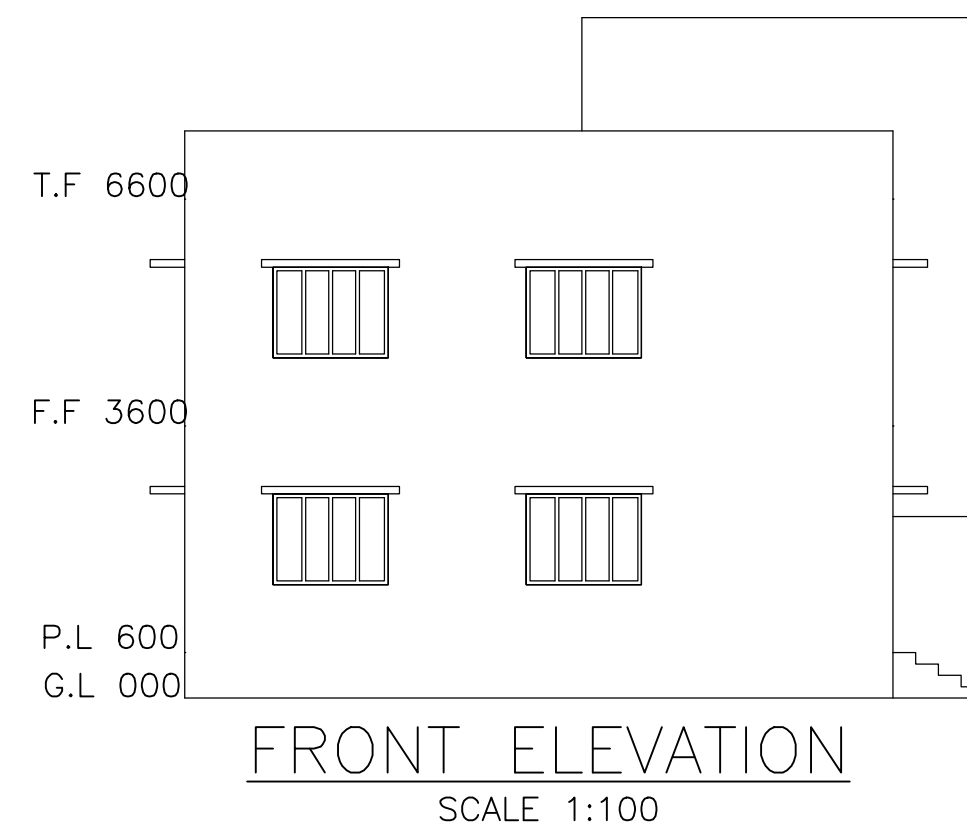

FRONT ELEVATION SCALE 1:100

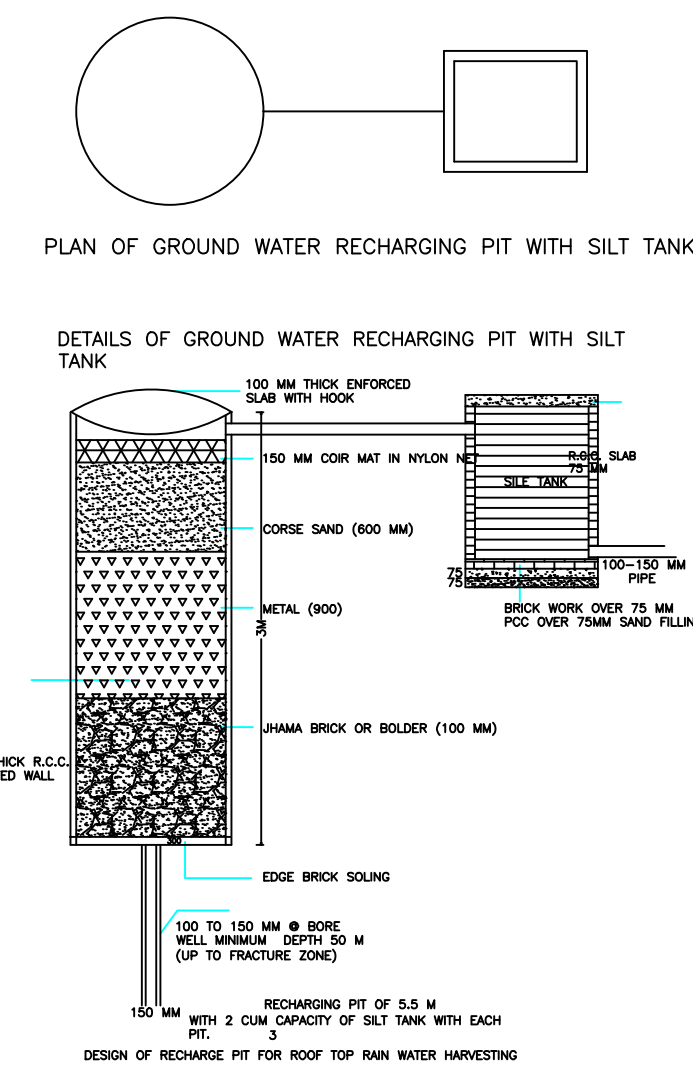

DETAILS OF GROUND WATER RECHARGING PIT WITH SILT TANK

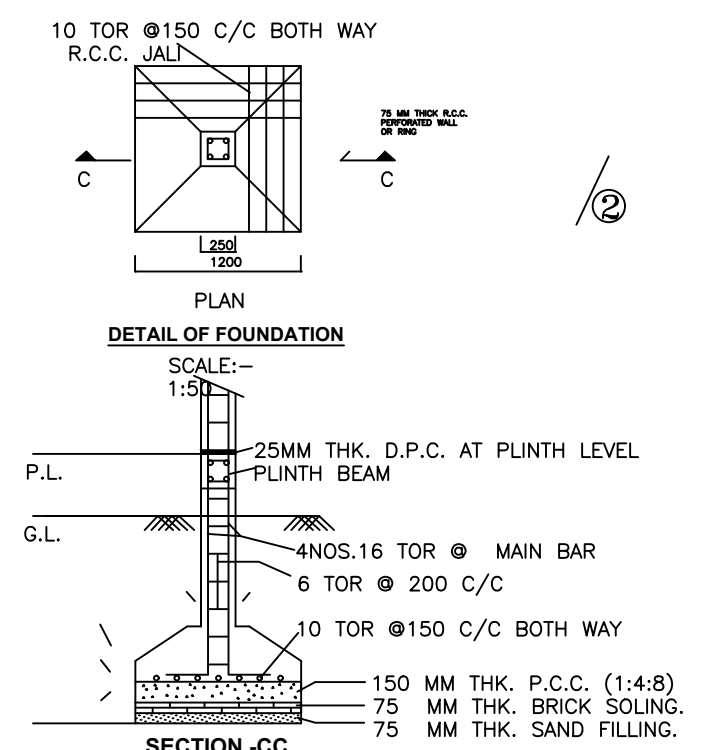

DETAIL OF FOUNDATION

Building :A1 (BUILDING)

Floor Name	Total Built Up Area (Sq.mt.)	Deductions (Area in Sq.mt.)	Proposed FAR Area (Sq.mt.)	Total FAR Area (Sq.mt.)	Total Consumed Additional FAR Area (Sq.mt.)	Trmt (No.)
Ground Floor	118.88	4.59	114.29	114.29	114.29	01
First Floor	118.87	4.59	114.28	114.28	114.28	01
Terrace Floor	0.00	0.00	0.00	0.00	0.00	00
Total:	237.75	9.18	228.57	228.57	228.57	02
Total Number of Same Buildings	1					
Total:	237.75	9.18	228.57	228.57	228.57	02

SCHEDULE OF DOOR:

BUILDING NAME	NAME	LENGTH	HEIGHT	NOS
A1 (BUILDING)	D2	0.76	2.10	04
A1 (BUILDING)	D1	0.91	2.10	02
A1 (BUILDING)	D	1.07	2.10	12
A1 (BUILDING)	D	1.22	2.10	01

SCHEDULE OF WINDOW/VENTILATION:

BUILDING NAME	NAME	LENGTH	HEIGHT	NOS
A1 (BUILDING)	V	0.46	1.20	04
A1 (BUILDING)	W1	1.22	1.20	03
A1 (BUILDING)	W	1.52	1.20	16

UnitBUA Table for Building :A1 (BUILDING)

FLOOR	Name	UnitBUA Type	UnitBUA Area	Carpet Area	No. of Rooms	No. of Tenement
GROUND FLOOR PLAN	SPLIT 1	FLAT	90.67	90.36	10	1
FIRST FLOOR PLAN	SPLIT 2	FLAT	90.44	90.13	10	1
Total:	-	-	181.11	180.49	20	2

LTP NAME AND SIGNATURE	STRUCTURAL ENG'S NAME AND SIGNATURE	BUILDER NAME AND SIGNATURE
RAJESH KUMAR SINPC/DFTMN/0006/2017		

Proposal Basic Information	
Proposal File No.	SINPC/BP/0030/W06/2018
Owner Name	SUNITA TETE
Khata No	152
Plot No	2170
Village Name	Khijri
Use	Residential
SubUse	Residential Bldg/Apartment

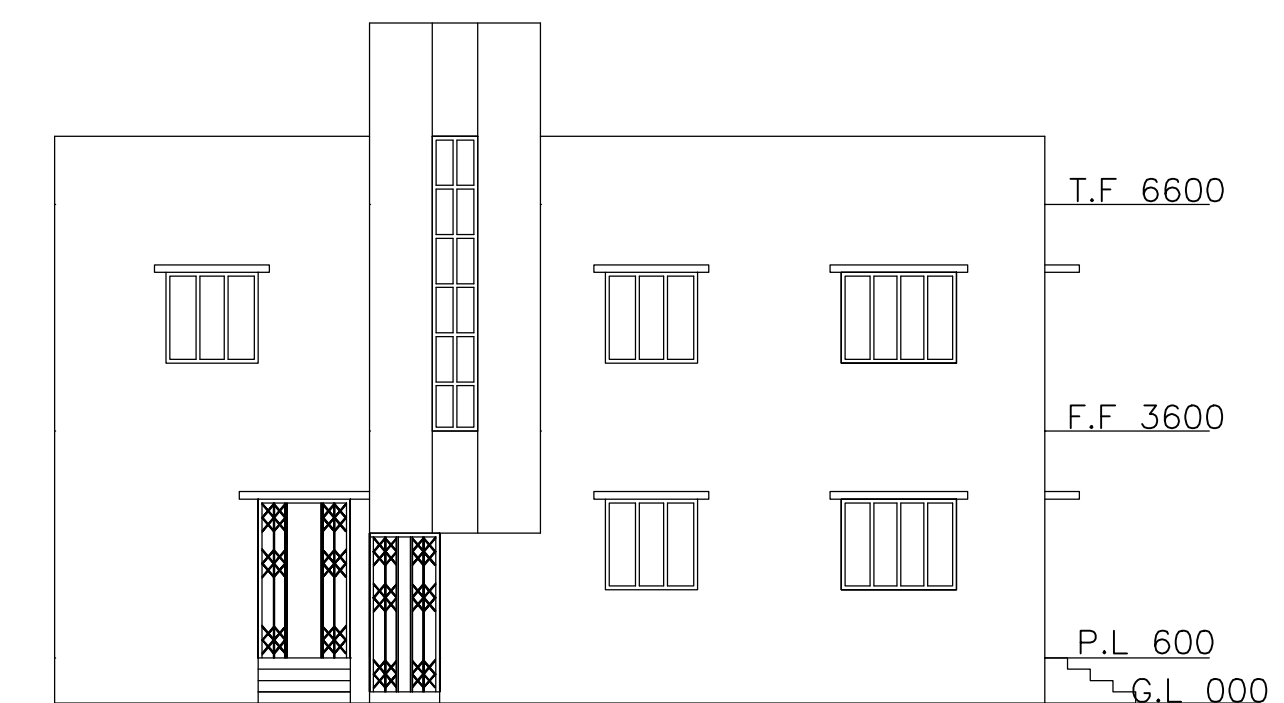

RIGHT SIDE ELEVATION
SCALE 1:100

LTP NAME AND SIGNATURE	STRUCTURAL ENG'S NAME AND SIGNATURE	BUILDER NAME AND SIGNATURE
RAJESH KUMAR SINPC/DFTMN/0008/2017		