

SITE PLAN

FAR & Tenement Details (Table 4c-1)

Building	No. of Same Bldg	Total Built Up Area (Sq.mt.)	Proposed FAR Area (Sq.mt.) Resi.	Total FAR Area (Sq.mt.)	Total Consumed Additional FAR Area (Sq.mt.)	Tnmt (No.)
A (SMT NOMITA MINZ)	1	116.97	116.97	116.97	116.97	01
Grand Total :	1	116.97	116.97	116.97	116.97	01

Proposal Basic Information

Proposal File No.	SINPC/BP/0043/W03/2018
Owner Name	NOMITA MINZ
Khata No	44
Plot No	400
Village Name	Saldega
Use	Residential
SubUse	Residential Bldg/Apartment

AREA STATEMENT SIMDEGA NAGAR PANCHAYAT		VERSION NO: 1.0.27
PROJECT DETAIL:		VERSION DATE: 18/05/2018
Region: JHARKHAND URBAN LOCAL BODIES	Plot Use: Residential	
District: SIMDEGA	Plot SubUse: Residential Bldg/Apartment	
Authority: SIMDEGA NAGAR PANCHAYAT	PlotNearbyReligiousStructure: NA	
Inward No: SINPC/BP/0043/W03/2018	PlotSubPlot No: 400	
Application Type: General Proposal	North: -	
Project Type: Building Permission	South: -	
Nature of Development: New	East: -	
	West: -	
AREA DETAILS:		
AREA OF PLOT (Minimum)	(A)	SQ.MT. 561.06
Deduction for NetPlot Area		
Surrender Free of Cost		30.55
Total		30.55
NET AREA OF PLOT(Gross Plot Area - Deduction from Gross Plot area)	(A-Deductions)	530.51
Deduction for Balance Plot Area(from Gross Plot Area)		
Surrender Free of Cost		30.55
Common Plot		104.11
Total		134.66
BALANCE AREA OF PLOT(Net Plot Area - Recreational/Amenity space)	(A-Deductions)	426.40
PLOT AREA FOR COVERAGE(Net Plot Area)	(A-Deductions)	530.51
Plot Area for FAR (Net Plot Area + Road Widening Area)	(A-Deductions)	561.06
COVERAGE CHECK		
Permissible Coverage area (60.00 %)		318.31
Proposed Coverage Area (22.05 %)		116.97
Total Prop. Coverage Area (22.05 %)		116.97
Balance coverage area (37.95 %)		201.34
FAR CHECK		
Perm. FAR Area (1.50)		841.59
Total Perm. FAR area		841.59
Residential FAR		116.97
Proposed FAR Area		116.97
Total Proposed FAR Area		116.97
Consumed FAR (Factor)		0.21
Balance FAR Area		724.62
BUILT UP AREA CHECK		
Total Proposed BuiltUp Area		116.97
ARCHITECT (Regd)		MD RAGIB SAYEED
ENGINEER (Regd)		
SUPERVISOR (Regd)		
OWNER (Regd)		NOMITA MINZ
DEVELOPMENT AUTHORITY		LOCAL BODY

COLOR INDEX	
PLOT BOUNDARY	Black
ABUTTING ROAD	Green
PROPOSED CONSTRUCTION	Red
COMMON PLOT	Yellow
ROAD WIDENING AREA	Blue
EXISTING (To be retained)	Blue
EXISTING (To be demolished)	Yellow

Buildingwise Floor FAR Details

Floor Name	Building Name		Total	
	Proposed Built Up Area (Sq.mt.)	Proposed FAR Area (Sq.mt.)	Total Proposed Built Up Area (Sq.mt.)	Total FAR Area (Sq.mt.)
Ground Floor	116.97	116.97	116.97	116.97
Terrace Floor	0.00	0.00	0.00	0.00
Total :	116.97	116.97	116.97	116.97

Building USE/SUBUSE Details

Building Name	Building Use	Building SubUse	Building Structure
A (SMT NOMITA MINZ)	Residential	Residential Bldg/Apartment	Non-Highrise

LTP NAME AND SIGNATURE	STRUCTURAL ENG'S NAME AND SIGNATURE	BUILDER NAME AND SIGNATURE
MD RAGIB SAYEED SINPC/ENG/0001/2017		

Proposal Basic Information	
Proposal File No.	SINPC/BP/0043/W03/2018
Owner Name	NOMITA MINZ
Khata No	44
Plot No	400
Village Name	Saldega
Use	Residential
SubUse	Residential Bldg/Apartment

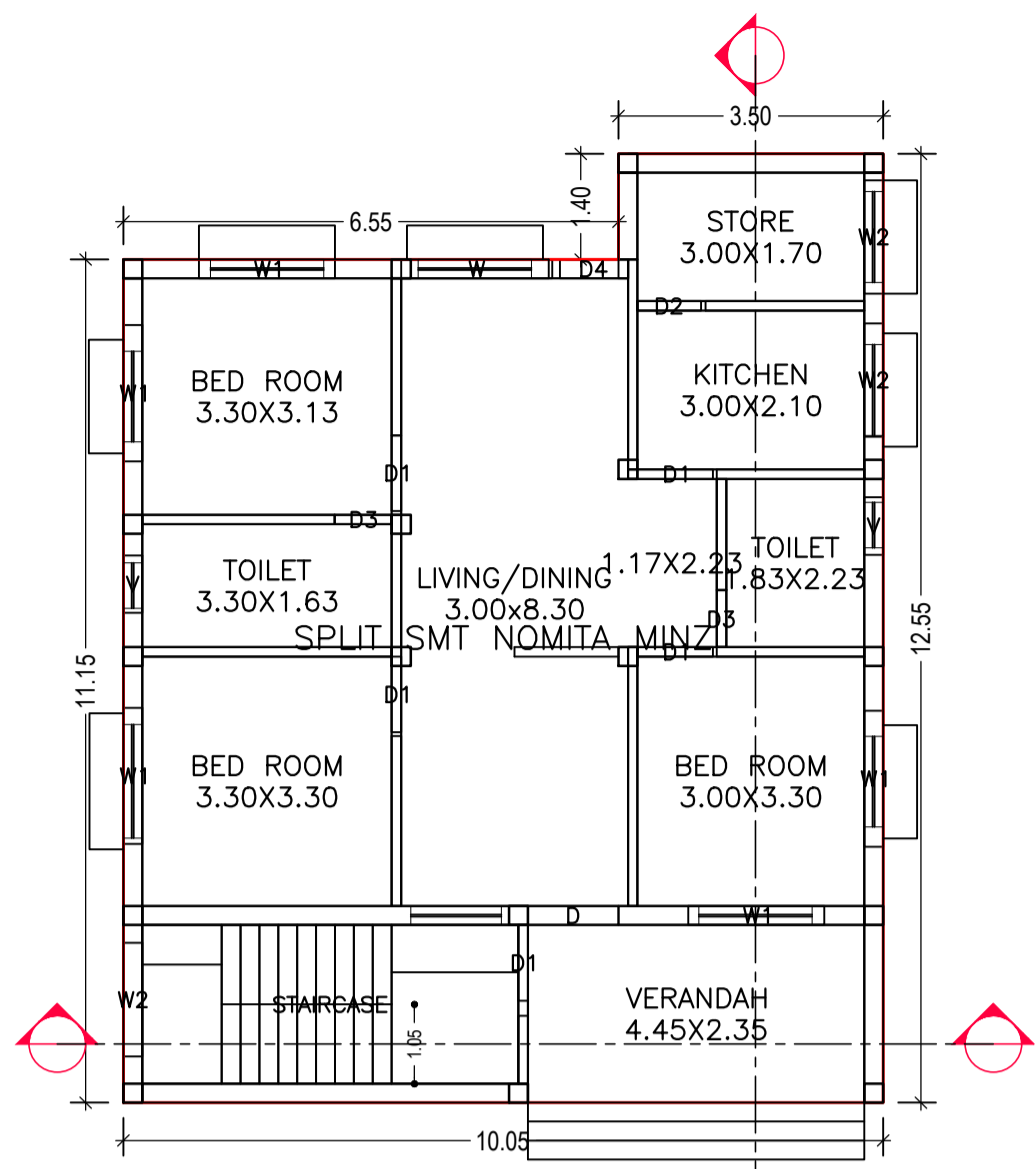

GROUND FLOOR PLAN (Proposed) (SCALE 1:100)

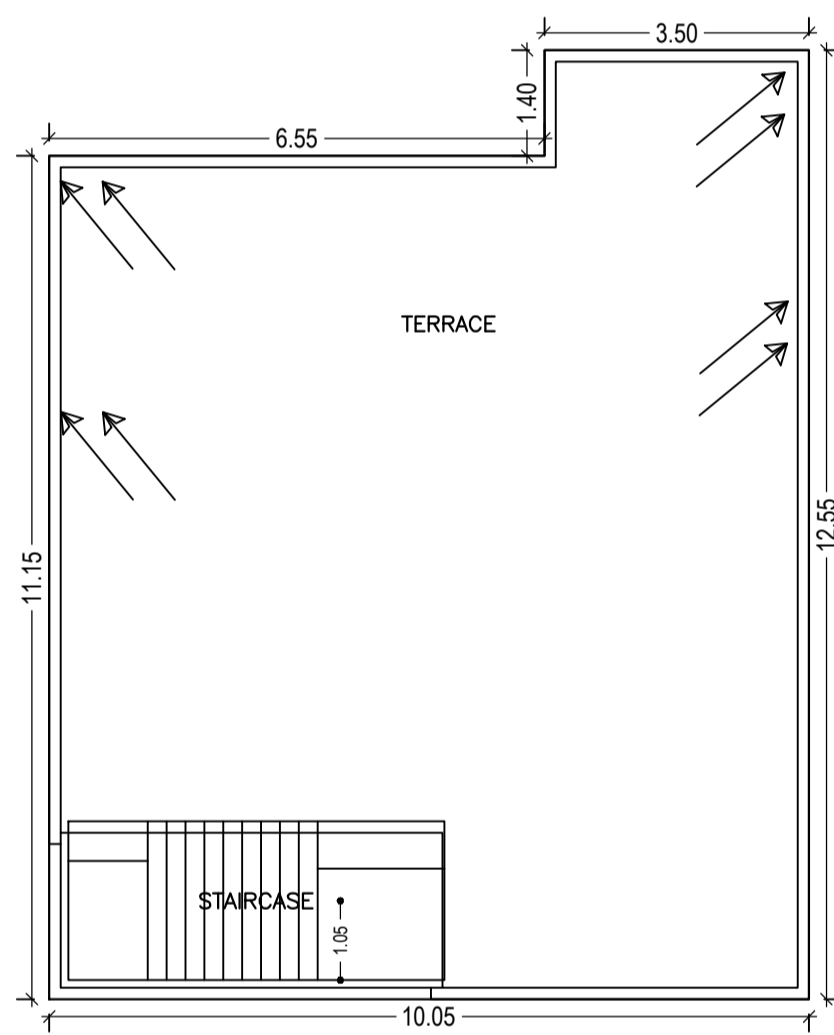

TERRACE FLOOR PLAN (SCALE 1:100)

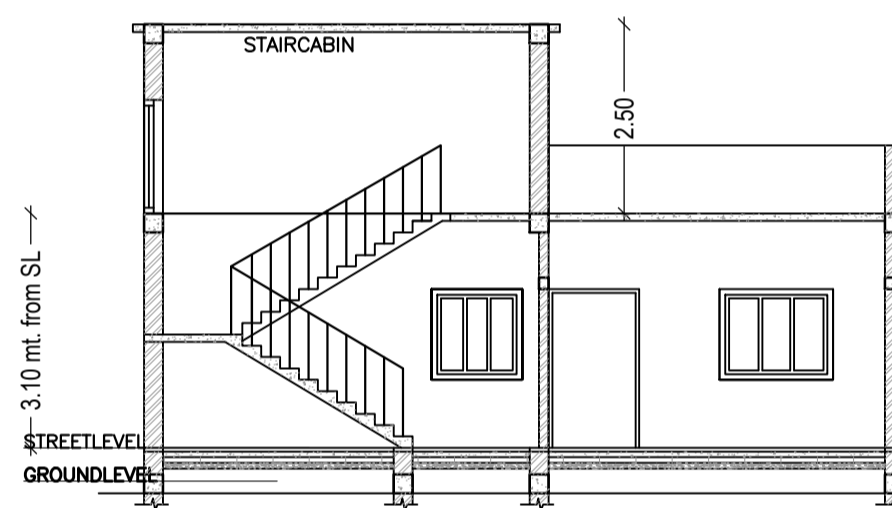

SECTION AT X-X' (SCALE-1:100)

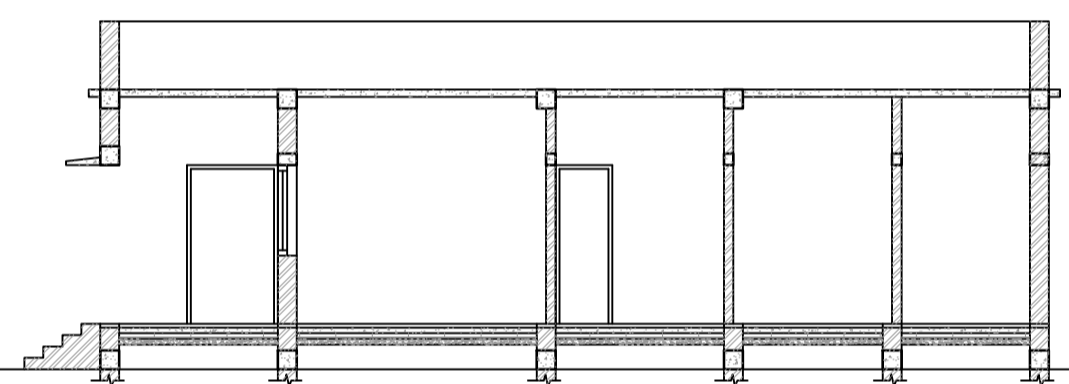

SECTION AT Y-Y' (SCALE-1:100)

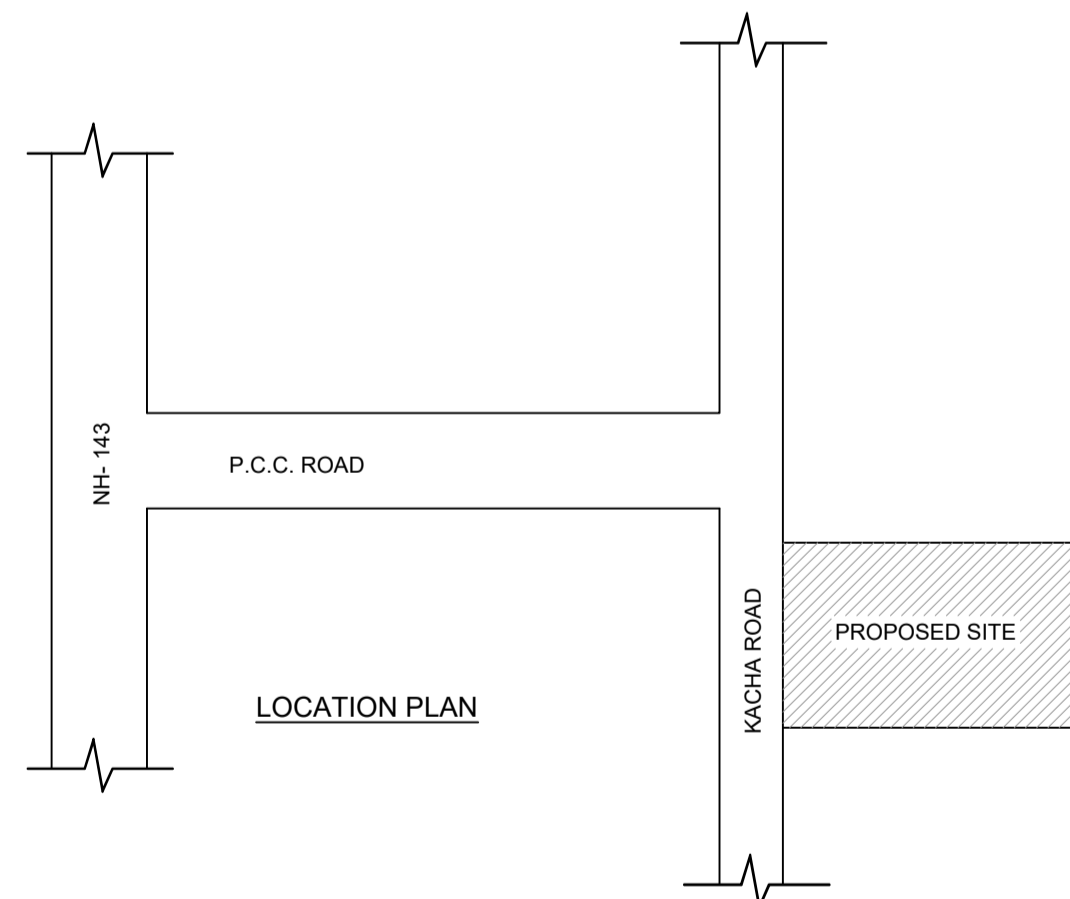

LOCATION PLAN

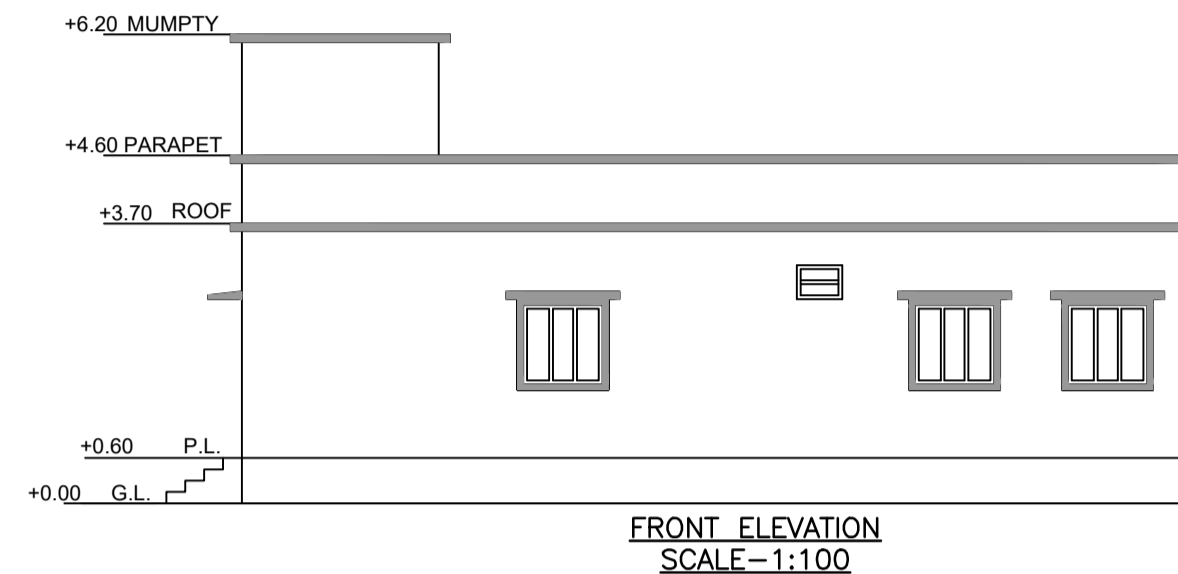

FRONT ELEVATION (SCALE-1:100)

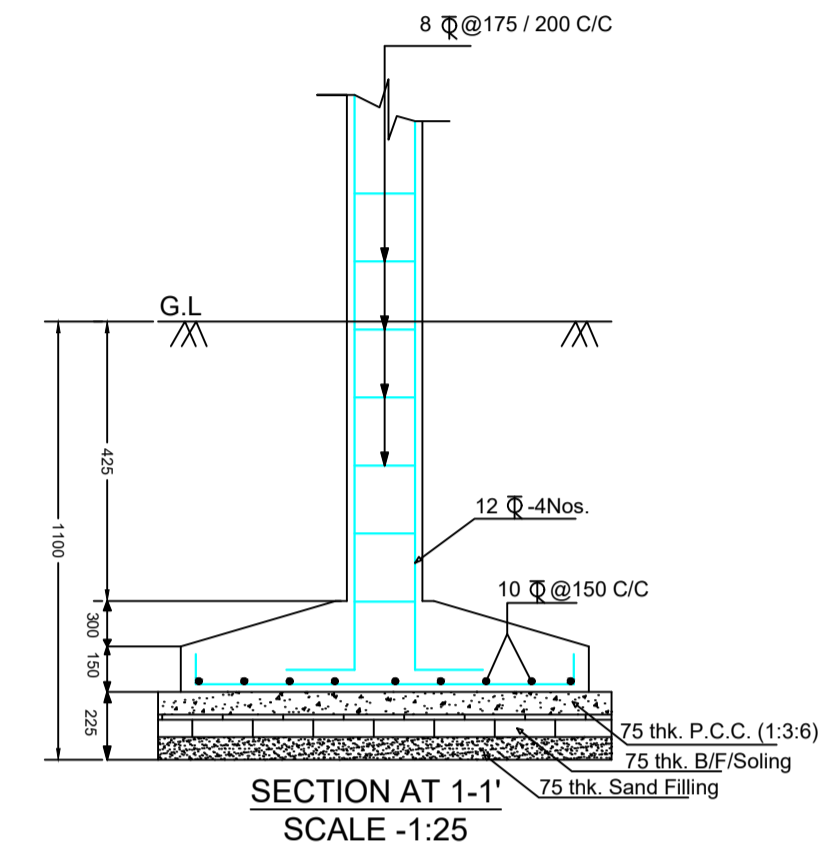

SECTION AT 1-1' (SCALE -1:25)

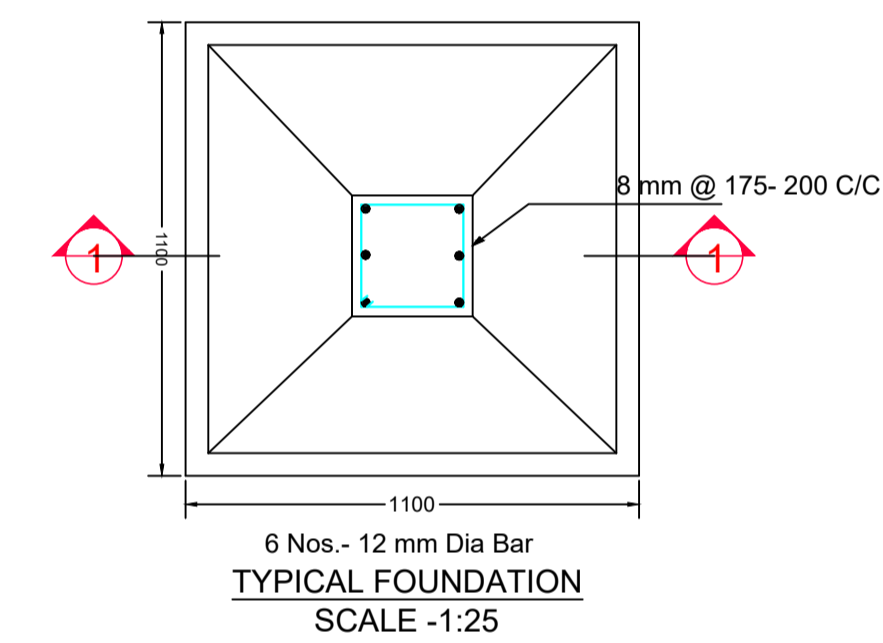

TYPICAL FOUNDATION (SCALE -1:25)

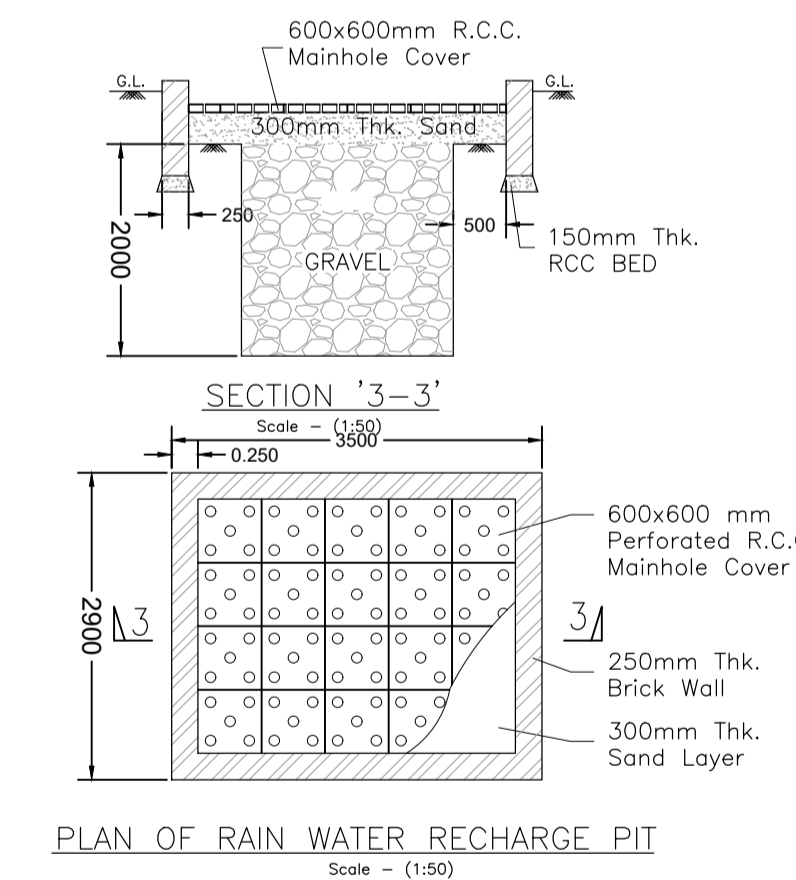

PLAN OF RAIN WATER RECHARGE PIT (Scale = 1:50)

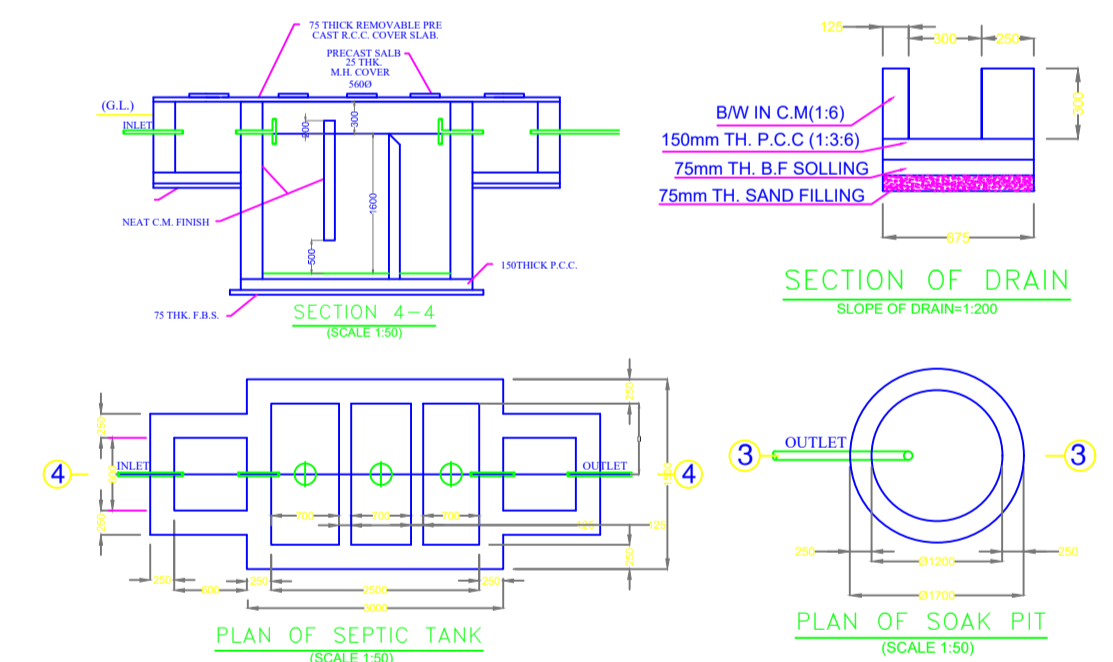

SECTION OF DRAIN (SCALE OF DRAIN=1:200)

PLAN OF SEPTIC TANK (SCALE 1:50)

PLAN OF SOAK PIT (SCALE 1:50)

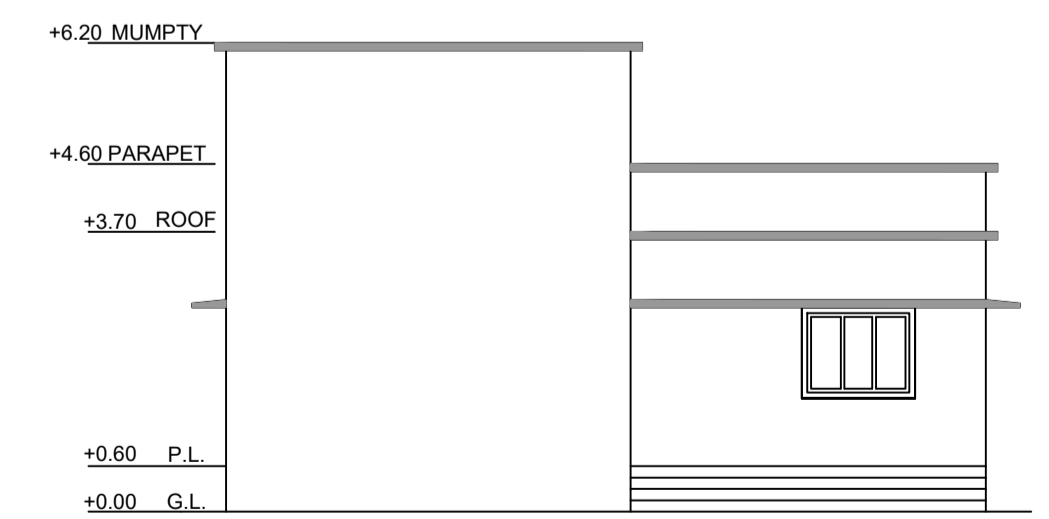

SIDE ELEVATION (SCALE-1:100)

SCHEDULE OF DOOR:

BUILDING NAME	NAME	LENGTH	HEIGHT	NOS
A (SMT NOMITA MINZ)	D3	0.76	2.13	02
A (SMT NOMITA MINZ)	D2	0.84	2.13	01
A (SMT NOMITA MINZ)	D4	0.90	2.13	01
A (SMT NOMITA MINZ)	D1	1.00	2.13	05
A (SMT NOMITA MINZ)	D	1.20	2.13	01

SCHEDULE OF WINDOW/VENTILATION:

BUILDING NAME	NAME	LENGTH	HEIGHT	NOS
A (SMT NOMITA MINZ)	V	0.76	0.76	02
A (SMT NOMITA MINZ)	W2	1.50	2.50	03
A (SMT NOMITA MINZ)	W1	1.80	2.50	05
A (SMT NOMITA MINZ)	W	2.00	2.50	01

Building :A (SMT NOMITA MINZ)

Floor Name	Total Built Up Area (Sq.mt.)	Proposed FAR Area (Sq.mt.)	Total FAR Area (Sq.mt.)	Total Consumed Additional FAR Area (Sq.mt.)	Tnmt (No.)
Ground Floor	116.97	116.97	116.97	116.97	01
Terrace Floor	0.00	0.00	0.00	0.00	00
Total:	116.97	116.97	116.97	116.97	01
Total Number of Same Buildings	1				
Total:	116.97	116.97	116.97	116.97	01

UnitBUA Table for Building :A (SMT NOMITA MINZ)

FLOOR	Name	UnitBUA Type	UnitBUA Area	Carpet Area	No. of Rooms	No. of Tenement
GROUND FLOOR PLAN	SPLIT SMT NOMITA MINZ	FLAT	95.05	91.34	9	1
Total:	-	-	95.05	91.34	9	1

LTP NAME AND SIGNATURE	STRUCTURAL ENG'S NAME AND SIGNATURE	BUILDER NAME AND SIGNATURE
MD RAGIB SAYEED SINPC/ENG/0001/2017		