

SITE PLAN

FAR & Tenement Details (Table 4c-1)

Building	No. of Same Bldg	Total Built Up Area (Sq.mt.)	Deductions (Area in Sq.mt.)		Proposed FAR Area (Sq.mt.)	Total FAR Area (Sq.mt.)	Total Consumed Additional FAR Area (Sq.mt.)	Trmnt (No.)
			Void	Resi.				
A1 (DEEPA GUPTA)	1	165.10	4.63		160.47	160.47	160.47	02
Grand Total :	1	165.10	4.63		160.47	160.47	160.47	02

Proposal Basic Information

Proposal File No.	SINPC/IBP/0087/W/14/2018
Owner Name	DEEPA GUPTA
Khata No	91
Plot No	610
Village Name	Saldega
Use	Residential
SubUse	Residential Bldg/Apartment

Required Parking (Table 7a)

Building Name	Type	SubUse	Area (Sq.mt.)	Units		Car		Visitors Car		TwoWheeler	
				Regd.	Prop.	Regd./Unit	Prop.	Regd./Unit	Prop.	Regd./Unit	Prop.
A1 (DEEPA GUPTA)	Residential	Residential Bldg/Apartment	> 0	1	2.00	1	2	-	-	-	-
			> 0	1	2.00	-	-	-	-	1	2
			> 0	1	2.00	-	-	1	1	-	-
Total :							2	2		1	2

Parking Check (Table 7b)

Vehicle Type	Reqd.		Prop.	
	No.	Area	No.	Area
Car	-	-	2	25.00
Total Car	2	25.00	2	25.00
Visitor's Car Parking	-	-	2	25.00
Total Visitor Parking	1	12.50	2	25.00
TwoWheeler	-	-	3	6.00
Total TwoWheeler	2	4.00	3	6.00
Other Parking	-	-	-	17.60
Total		41.50		104.60

AREA STATEMENT SIMDEGA NAGAR PANCHAYAT	VERSION NO: 1.0.37	VERSION DATE: 29/04/2019
PROJECT DETAIL:	Plot Use: Residential	
Region: JHARKHAND URBAN LOCAL BODIES	Plot SubUse: Residential Bldg/Apartment	
District: SIMDEGA	PlotNearby/ReligiousStructure: NA	
Authority: SIMDEGA NAGAR PANCHAYAT	PlotSubPlot No: 610	
Inward No: SINPC/IBP/0087/W/14/2018	North: -	
Application Type: General Proposal	South: -	
Project Type: Building Permission	East: -	
Nature of Development: New	West: -	
Location of Development Area: Old Area		
AREA DETAILS:		SQ.MT.
AREA OF PLOT (Minimum)	(A)	167.93
Deduction for NetPlot Area		
Surrender Free of Cost		20.76
Total		20.76
NET AREA OF PLOT(Gross Plot Area - Deduction from Gross Plot area)	(A-Deductions)	147.17
Deduction for Balance Plot Area(from Gross Plot Area)		
Surrender Free of Cost		20.76
Common Plot		21.54
Total		42.30
BALANCE AREA OF PLOT(Net Plot Area - Recreational/Amenity space)	(A-Deductions)	125.62
PLOT AREA FOR COVERAGE(Net Plot Area)	(A-Deductions)	147.17
	(A-Deductions)	167.93
COVERAGE CHECK		
Permissible Coverage area (70.00 %)		103.02
Proposed Coverage Area (56.09 %)		82.55
Total Prop. Coverage Area (56.09 %)		82.55
Balance coverage area (13.91 %)		20.47
FAR CHECK		
Perm. FAR Area (1.20)		201.52
Total Perm. FAR area		201.52
Residential FAR		160.47
Proposed FAR Area		160.47
Total Proposed FAR Area		160.47
Consumed FAR (Factor)		0.96
Balance FAR Area		41.05
BUILT UP AREA CHECK		
Total Proposed BuiltUp Area		165.10
ARCHITECT (Regd)	RAJESH KUMAR	
ENGINEER (Regd)		
SUPERVISOR (Regd)		
OWNER (Regd)	DEEPA GUPTA	
		LOCAL BODY

COLOR INDEX	
PLOT BOUNDARY	Black
ABUTTING ROAD	Green
PROPOSED CONSTRUCTION	Red
COMMON PLOT	Yellow
ROAD WIDENING AREA	Blue
EXISTING (To be retained)	Blue
EXISTING (To be demolished)	Yellow

Buildingwise Floor FAR Details

Floor Name	Building Name		Total	
	Proposed Built Up Area (Sq.mt.)	Proposed FAR Area (Sq.mt.)	Total Proposed Built Up Area (Sq.mt.)	Total FAR Area (Sq.mt.)
Ground Floor	82.55	80.14	82.55	80.14
First Floor	82.55	80.33	82.55	80.33
Terrace Floor	0.00	0.00	0.00	0.00
Total :	165.10	160.47	165.10	160.47

Building USE/SUBUSE Details

Building Name	Building Use	Building SubUse	Building Structure
A1 (DEEPA GUPTA)	Residential	Residential Bldg/Apartment	Non-Highrise

LTP NAME AND SIGNATURE	STRUCTURAL ENG'S NAME AND SIGNATURE	BUILDER NAME AND SIGNATURE	DIGITAL SIGNATURE
RAJESH KUMAR SINPC/DFTMIN/0006/2017			

Proposal Basic Information	
Proposal File No.	SINPC/BP/0087/W14/2018
Owner Name	DEEPA GUPTA
Khata No	91
Plot No	610
Village Name	Saldega
Use	Residential
SubUse	Residential Bldg/Apartment

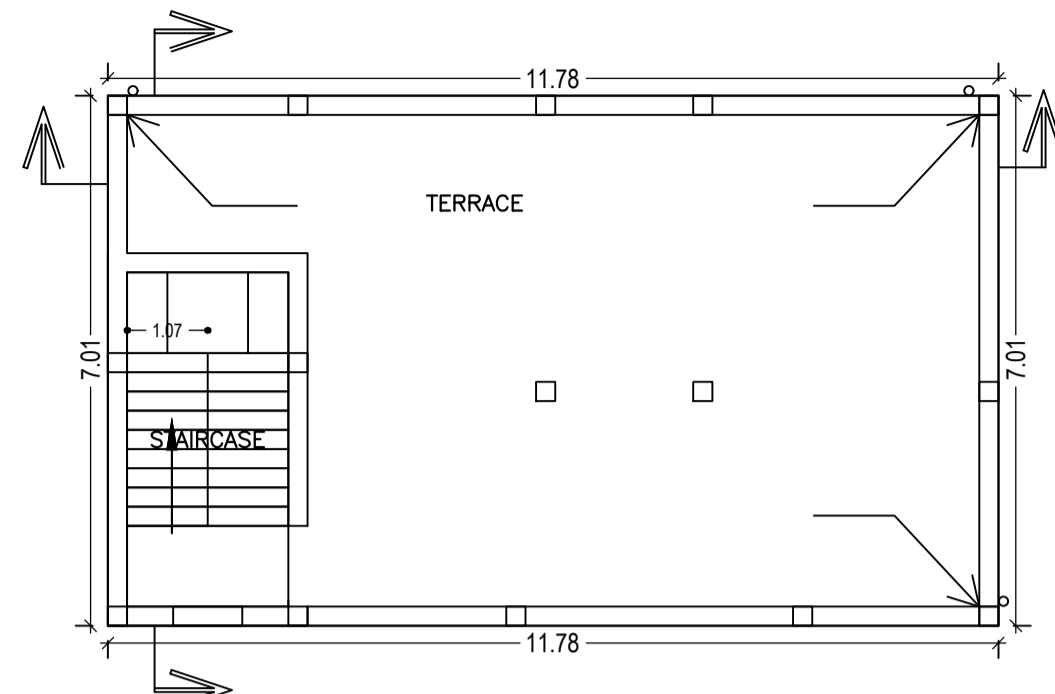
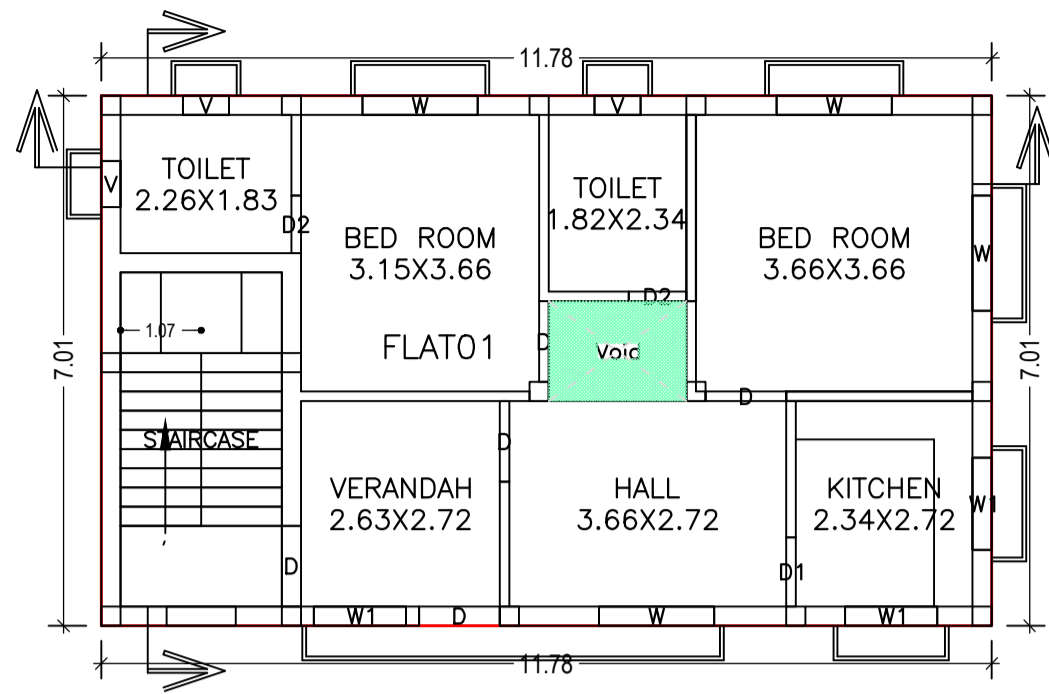

TERRACE FLOOR PLAN (SCALE 1:100)

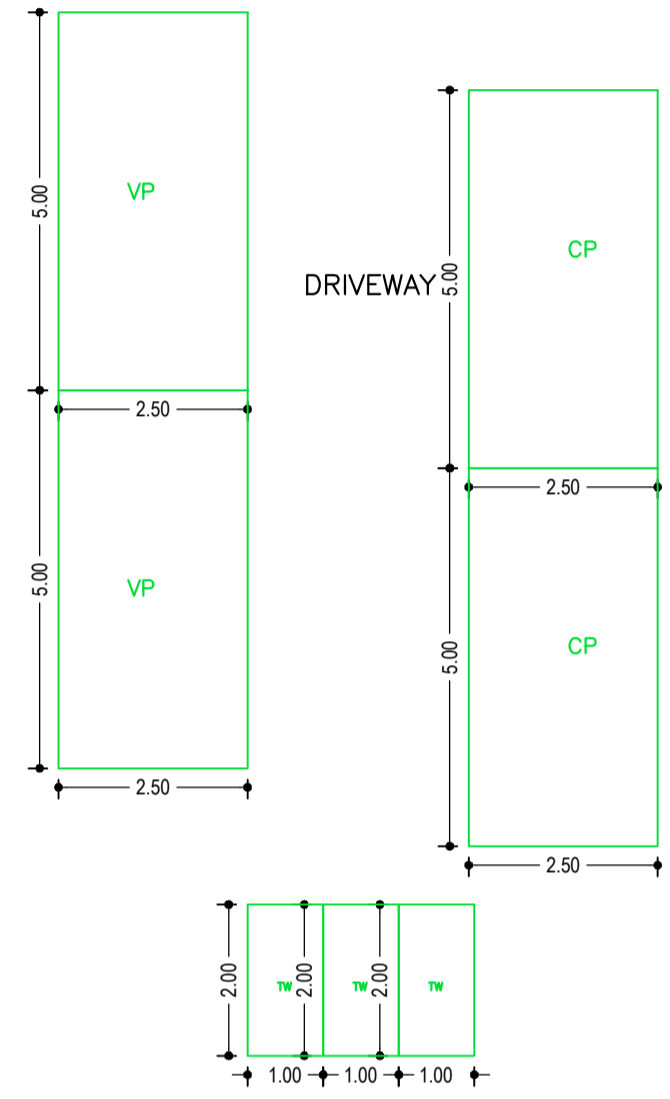

GROUND FLOOR PLAN (Proposed) (SCALE 1:100)

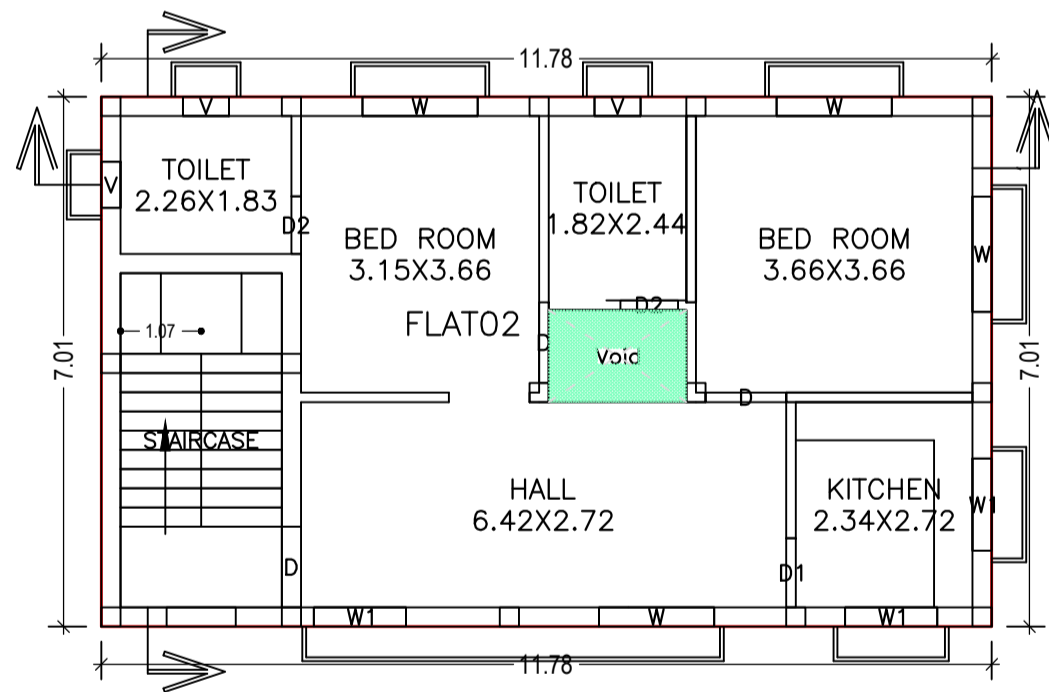

FIRST FLOOR PLAN (Proposed) (SCALE 1:100)

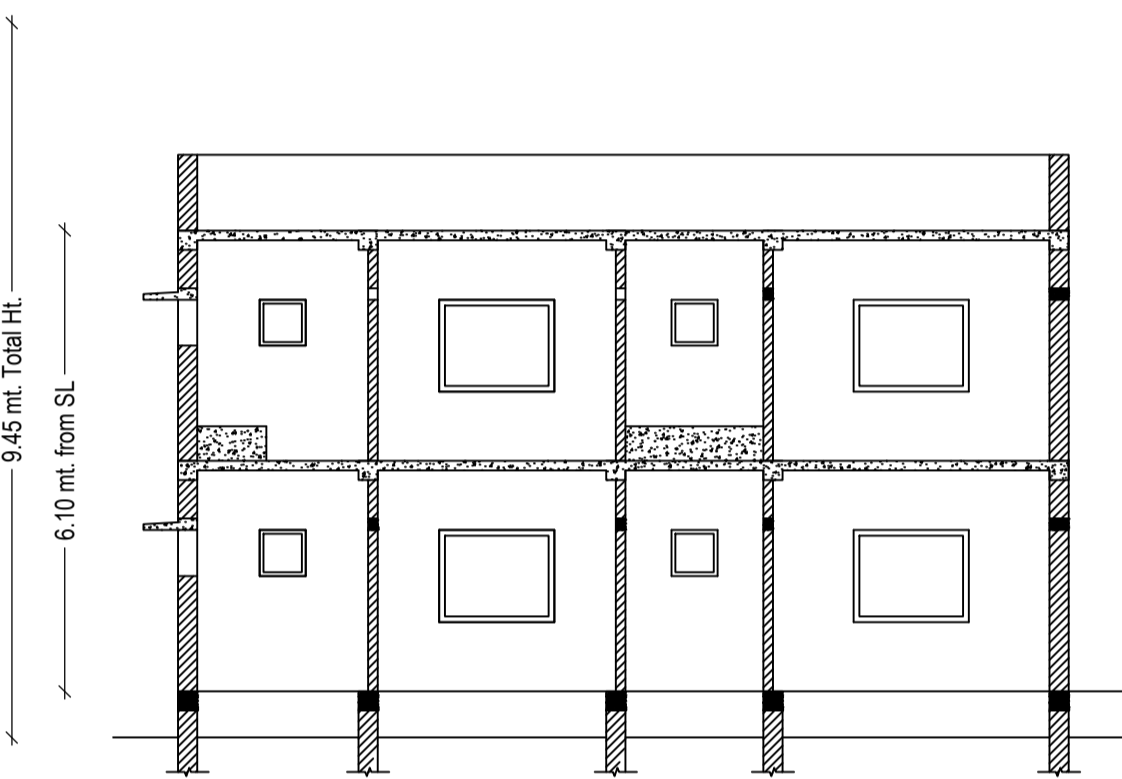

SECTION AT: X-X (SCALE 1:100)

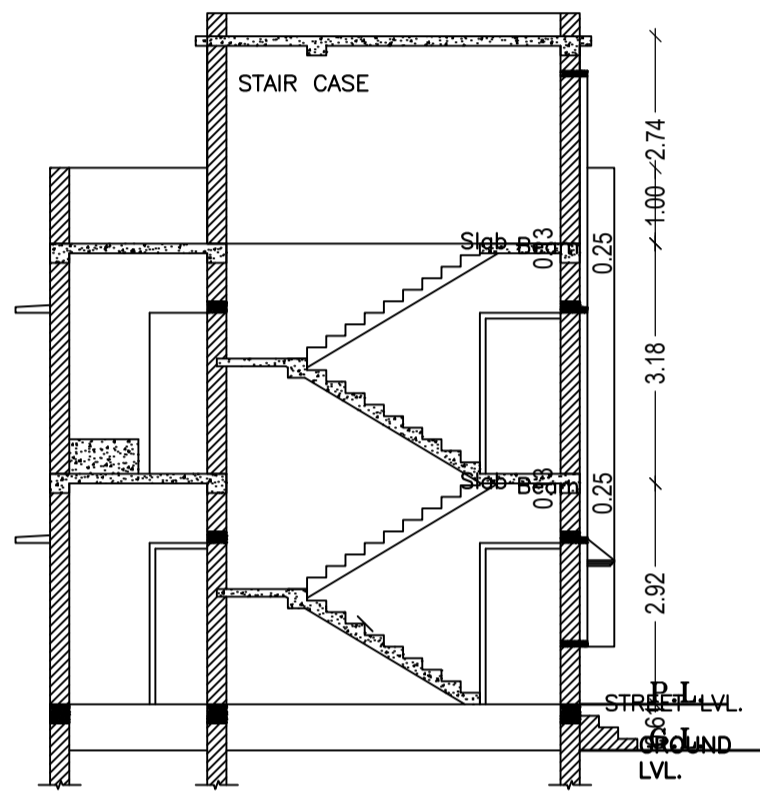

SECTION AT: Z-Z (SCALE 1:100)

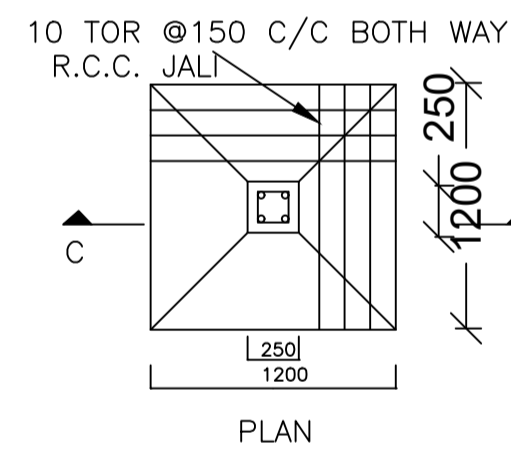

DETAIL OF FOUNDATION (SCALE: 1:50)

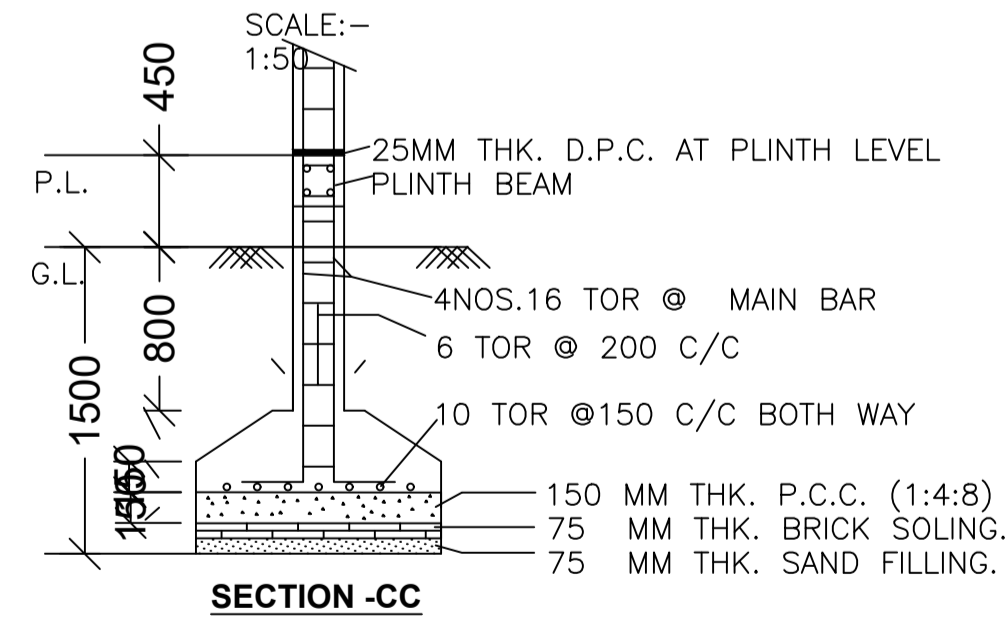

SECTION -CC

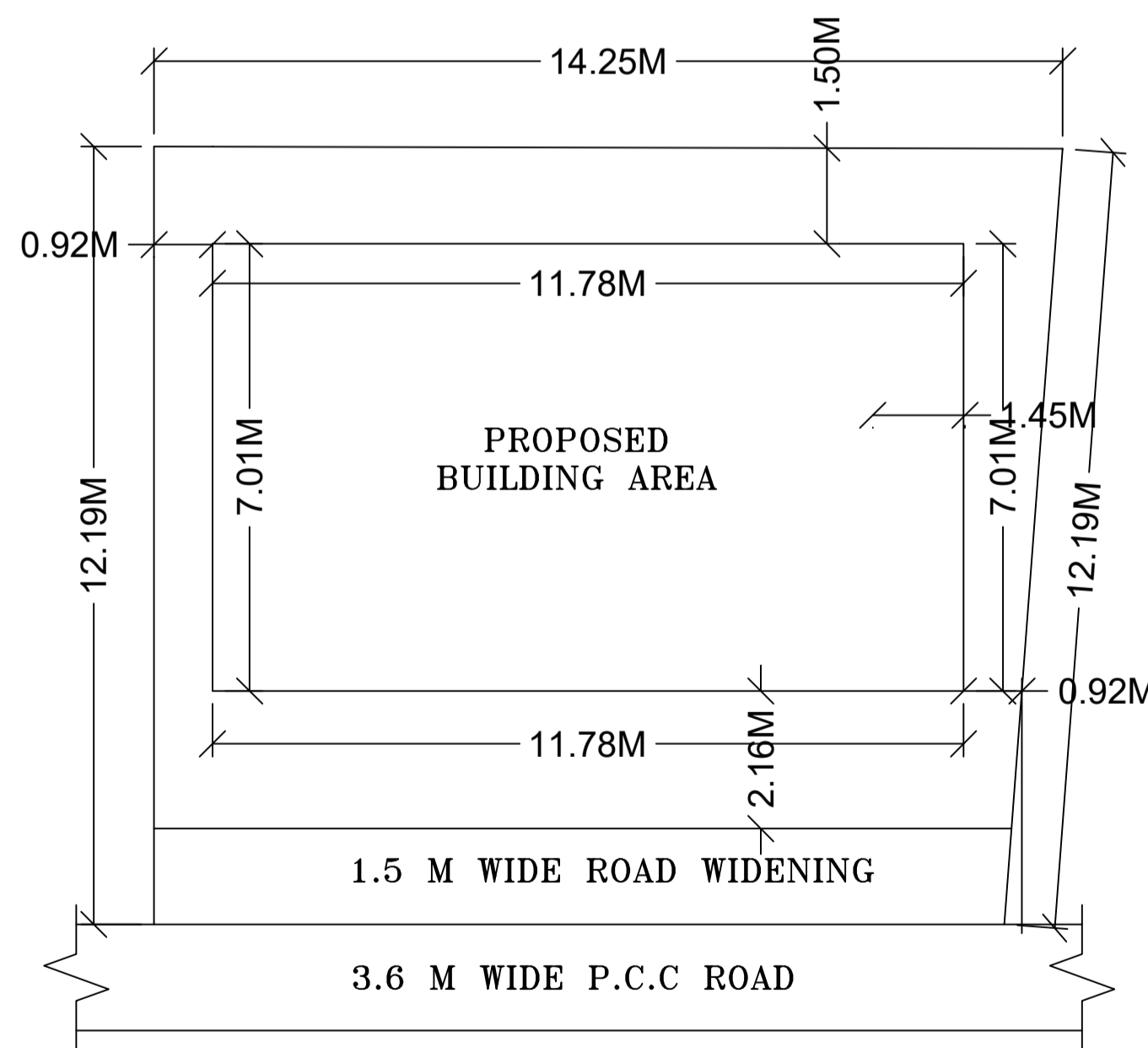

SITE PLAN (SCALE 1:100)

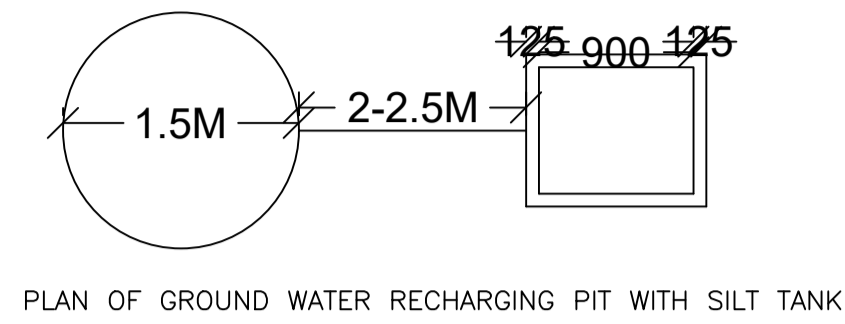

PLAN OF GROUND WATER RECHARGING PIT WITH SILT TANK

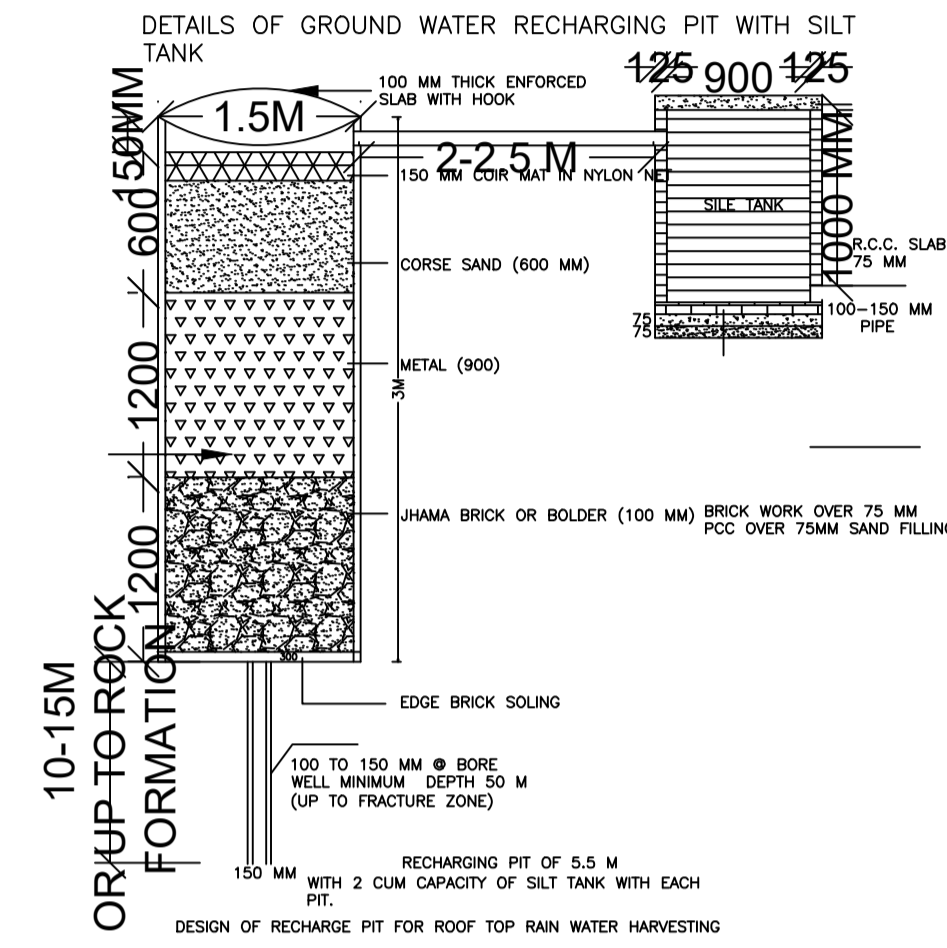

DETAILS OF GROUND WATER RECHARGING PIT WITH SILT TANK



FRONT ELEVATION (SCALE 1:100)

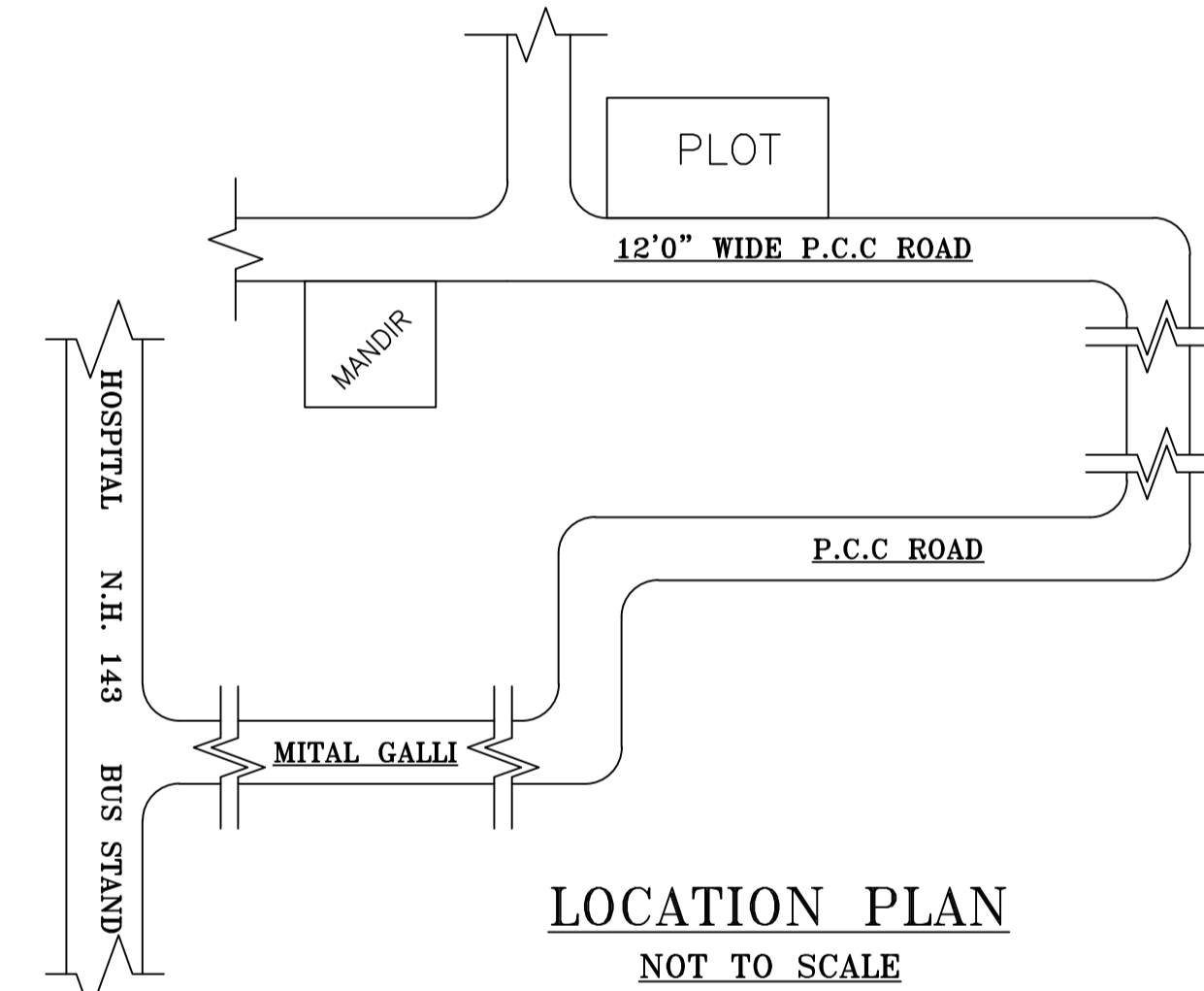

LOCATION PLAN (NOT TO SCALE)

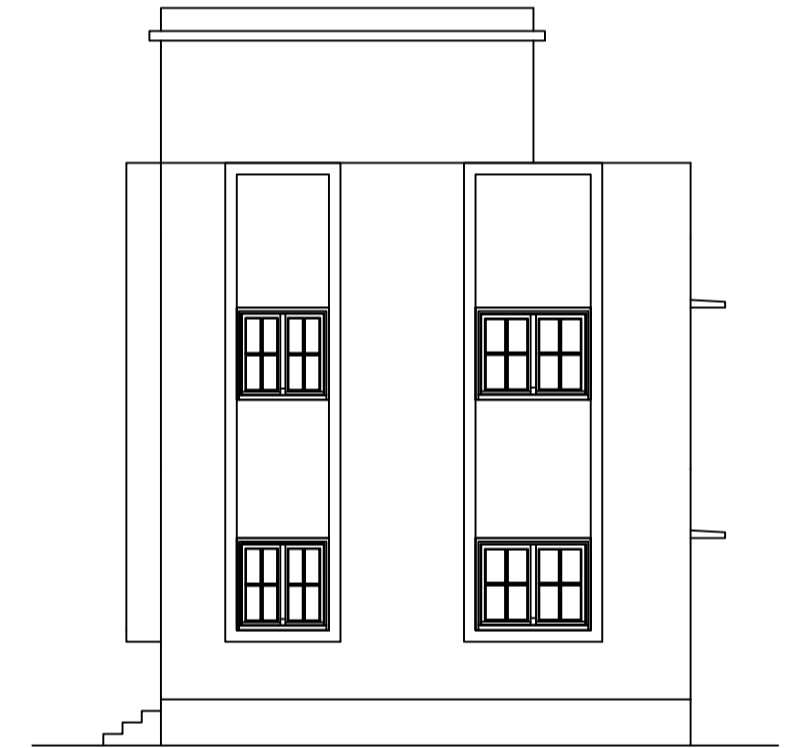

RIGHT SIDE ELEVATION (SCALE 1:100)

Building :A1 (DEEPA GUPTA)

Floor Name	Total Built Up Area (Sq.mt.)	Deductions (Area in Sq.mt.)	Proposed FAR Area (Sq.mt.)	Total FAR Area (Sq.mt.)	Total Consumed Additional FAR Area (Sq.mt.)	Trmt (No.)
Ground Floor	82.55	2.41	80.14	80.14	80.14	01
First Floor	82.55	2.22	80.33	80.33	80.33	01
Terrace Floor	0.00	0.00	0.00	0.00	0.00	00
Total:	165.10	4.63	160.47	160.47	160.47	02
Total Number of Same Buildings	1					
Total:	165.10	4.63	160.47	160.47	160.47	02

SCHEDULE OF DOOR:

BUILDING NAME	NAME	LENGTH	HEIGHT	NOS
A1 (DEEPA GUPTA)	D2	0.76	2.10	04
A1 (DEEPA GUPTA)	D1	0.91	2.10	02
A1 (DEEPA GUPTA)	D	1.07	2.10	08

SCHEDULE OF WINDOW/VENTILATION:

BUILDING NAME	NAME	LENGTH	HEIGHT	NOS
A1 (DEEPA GUPTA)	V	0.61	1.20	06
A1 (DEEPA GUPTA)	W1	1.22	1.20	06
A1 (DEEPA GUPTA)	W	1.52	1.20	08

UnitBUA Table for Building :A1 (DEEPA GUPTA)

FLOOR	Name	UnitBUA Type	UnitBUA Area	Carpet Area	No. of Rooms	No. of Tenement
GROUND FLOOR PLAN	FLAT01	FLAT	59.70	59.07	7	1
FIRST FLOOR PLAN	FLAT02	FLAT	59.88	59.26	6	1
Total:	-	-	119.58	118.33	13	2

LTP NAME AND SIGNATURE	STRUCTURAL ENG'S NAME AND SIGNATURE	BUILDER NAME AND SIGNATURE	DIGITAL SIGNATURE
RAJESH KUMAR SINPC/DFTMN/0006/2017			

Proposal Basic Information	
Proposal File No.	SINPC/BP/0087/W14/2018
Owner Name	DEEPA GUPTA
Khata No	91
Plot No	610
Village Name	Saldega
Use	Residential
SubUse	Residential Bldg/Apartment

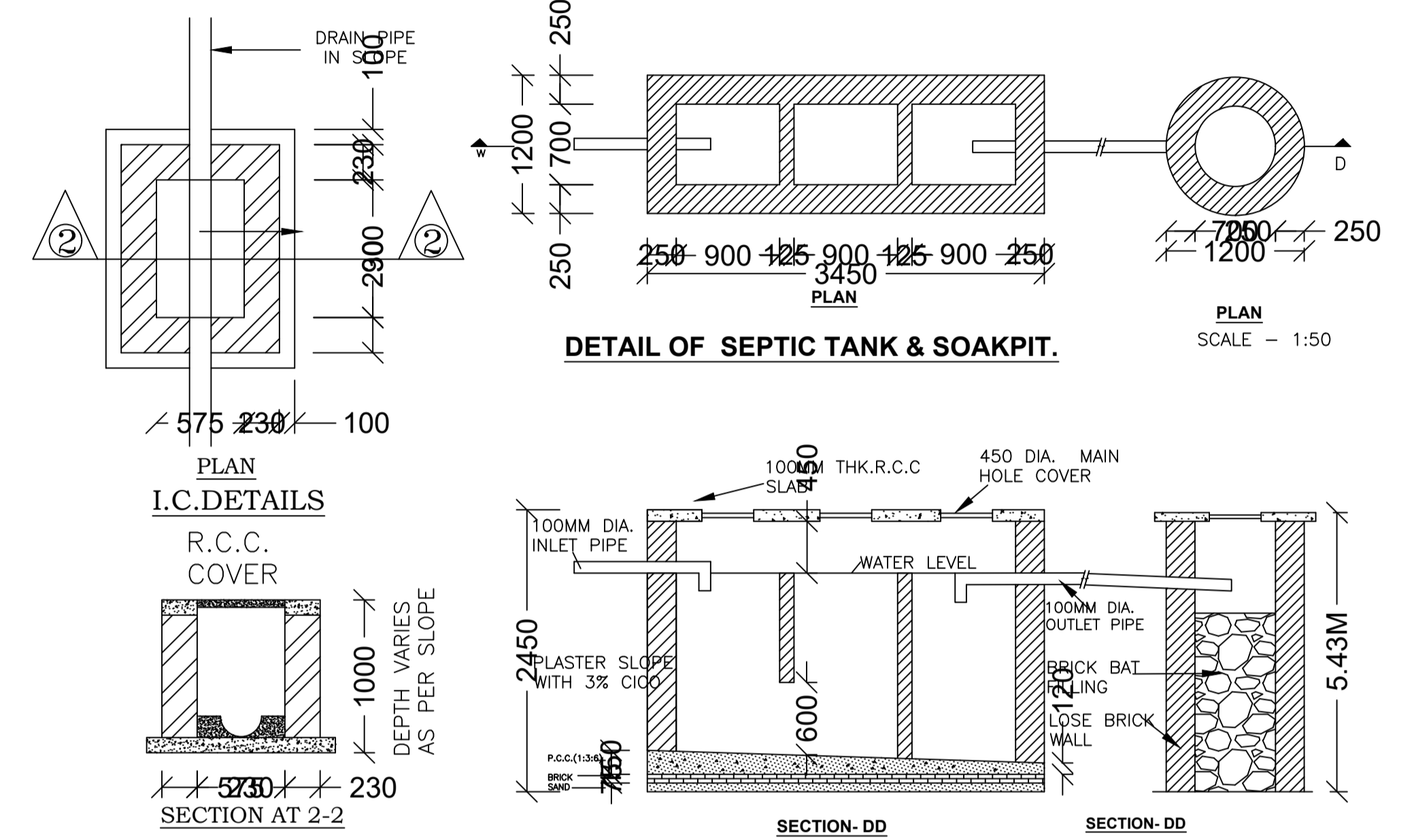

LTP NAME AND SIGNATURE	STRUCTURAL ENG'S NAME AND SIGNATURE	BUILDER NAME AND SIGNATURE	DIGITAL SIGNATURE
RAJESH KUMAR SINPC/DFTMN/0006/2017			