

SITE PLAN

SCALE 1:100
(Scale - 1:200)

FAR & Tenement Details (Table 4c-1)

Building	No. of Same Bldg	Total Built Up Area (Sq.mt.)	Deductions (Area in Sq.mt.)		Proposed FAR Area (Sq.mt.)	Total FAR Area (Sq.mt.)	Total Consumed Additional FAR Area (Sq.mt.)	Trmnt (No.)
			Void	Resi.				
A1 (BUILDING)	1	228.52	10.18		218.34	218.34	218.34	01
Grand Total :	1	228.52	10.18		218.34	218.34	218.34	01

Proposal Basic Information

Proposal File No.	SINPC/BP/0022/W06/2018
Owner Name	VILSAN KERKETTA
Khata No	19
Plot No	2727,2728
Village Name	Khijiri
Use	Residential
SubUse	Residential Bldg/Apartment

AREA STATEMENT SIMDEGA NAGAR PANCHAYAT		VERSION NO. : 1.0.27
PROJECT DETAIL:		VERSION DATE: 18/05/2018
Region: JHARKHAND URBAN LOCAL BODIES	Plot Use: Residential	
District: SIMDEGA	Plot SubUse: Residential Bldg/Apartment	
Authority: SIMDEGA NAGAR PANCHAYAT	PlotNearbyReligiousStructure: NA	
Inward No: SINPC/BP/0022/W06/2018	PlotSubPlot No: 2727,2728	
Application Type: General Proposal	North: -	
Project Type: Building Permission	South: -	
Nature of Development: New	East: -	
Location of Development Area: New Area	West: -	
AREA DETAILS:		
AREA OF PLOT (Minimum)	(A)	SQ.MT. 504.43
Deduction for NetPlot Area		
Road Widening Area		16.31
Total		16.31
NET AREA OF PLOT(Gross Plot Area - Deduction from Gross Plot area)		
(A-Deductions)		488.12
Deduction for Balance Plot Area(from Gross Plot Area)		
Road Widening Area		16.31
Common Plot		225.52
Total		241.83
BALANCE AREA OF PLOT(Net Plot Area - Recreational/Amenity space)		
(A-Deductions)		262.60
PLOT AREA FOR COVERAGE(Net Plot Area)		
(A-Deductions)		488.12
Plot Area for FAR (Net Plot Area + RoadWidening Area)		
(A-Deductions)		488.12
COVERAGE CHECK		
Permissible Coverage area (60.00 %)		292.87
Proposed Coverage Area (23.41 %)		114.26
Total Prop. Coverage Area (23.41 %)		114.26
Balance coverage area (36.59 %)		178.61
FAR CHECK		
Perm. FAR Area (1.50)		732.18
Total Perm. FAR area		732.18
Residential FAR		218.34
Proposed FAR Area		218.34
Total Proposed FAR Area		218.34
Consumed FAR (Factor)		0.45
Balance FAR Area		513.84
BUILT UP AREA CHECK		
Total Proposed BuiltUp Area		228.52
ARCHITECT (Regd)	RAJESH KUMAR	
ENGINEER (Regd)		
SUPERVISOR (Regd)		
OWNER (Regd)	VILSAN KERKETTA	
DEVELOPMENT AUTHORITY		LOCAL BODY

COLOR INDEX	
PLOT BOUNDARY	Black
ABUTTING ROAD	Green
PROPOSED CONSTRUCTION	Red
COMMON PLOT	Yellow
ROAD WIDENING AREA	Orange
EXISTING (To be retained)	Blue
EXISTING (To be demolished)	Light Blue

Buildingwise Floor FAR Details

Floor Name	Building Name		Total	
	Proposed Built Up Area (Sq.mt.)	Proposed FAR Area (Sq.mt.)	Total Proposed Built Up Area (Sq.mt.)	Total FAR Area (Sq.mt.)
Ground Floor	114.26	109.17	114.26	109.17
First Floor	114.26	109.17	114.26	109.17
Terrace Floor	0.00	0.00	0.00	0.00
Total :	228.52	218.34	228.52	218.34

Building USE/SUBUSE Details

Building Name	Building Use	Building SubUse	Building Structure
A1 (BUILDING)	Residential	Residential Bldg/Apartment	Non-Highrise

LTP NAME AND SIGNATURE	STRUCTURAL ENG'S NAME AND SIGNATURE	BUILDER NAME AND SIGNATURE
RAJESH KUMAR SINPC/DFTMN/0008/2017		

Proposal Basic Information	
Proposal File No.	SINPC/0022/W06/2018
Owner Name	VILSAN KERKETTA
Khata No	19
Plot No	2727.2728
Village Name	Khijri
Use	Residential
SubUse	Residential Bldg/Apartment

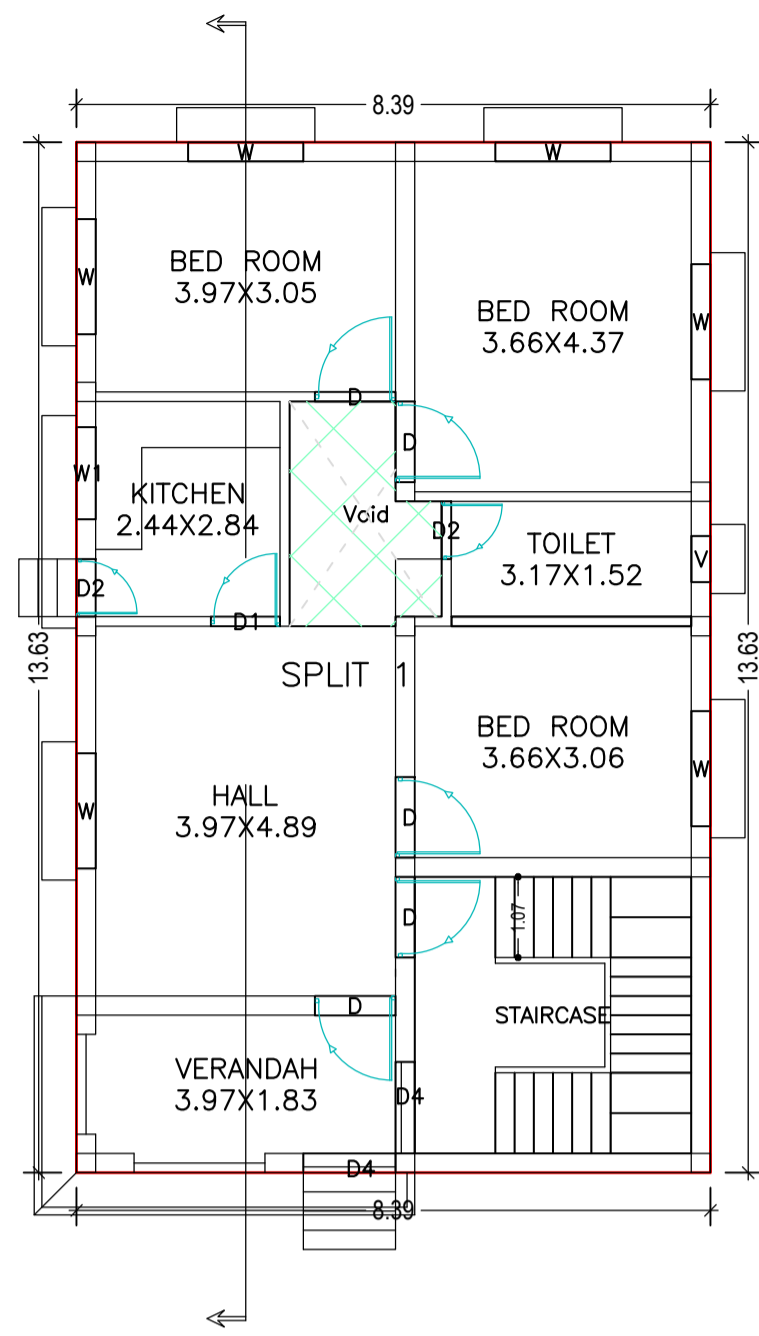

GROUND FLOOR PLAN (Proposed) (SCALE 1:100)

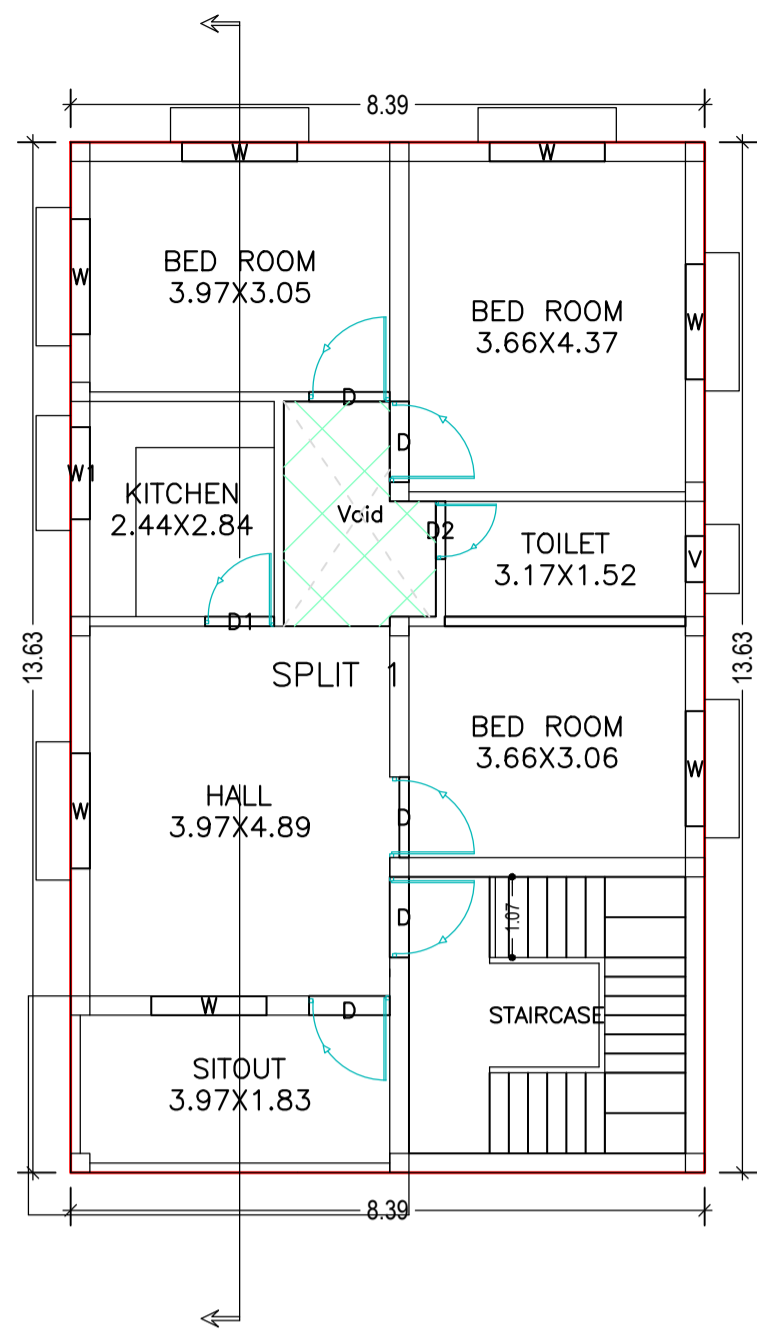

FIRST FLOOR PLAN (Proposed) (SCALE 1:100)

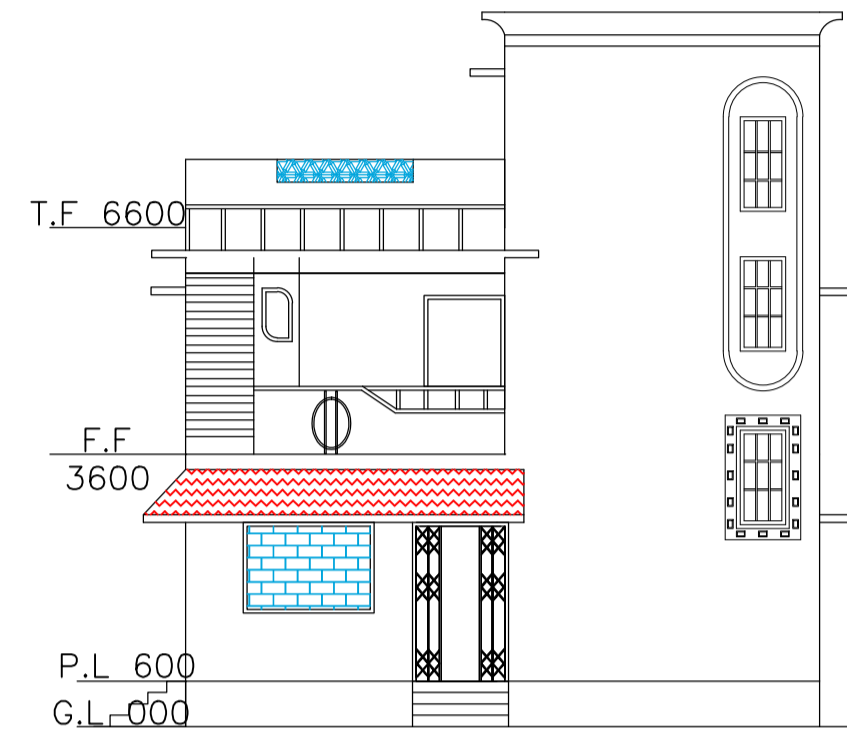

FRONT ELEVATION SCALE 1:100

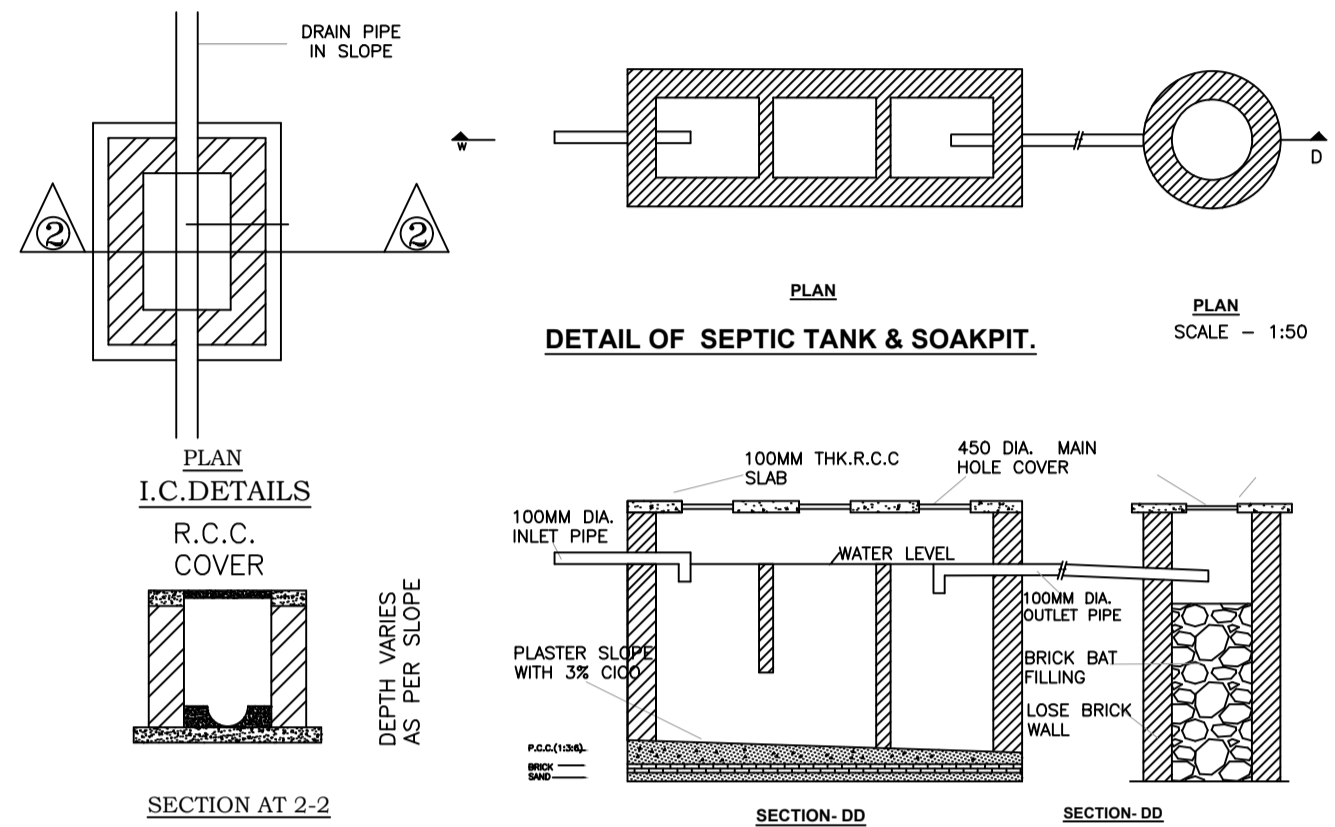

DETAIL OF SEPTIC TANK & SOAKPIT. PLAN SCALE - 1:50

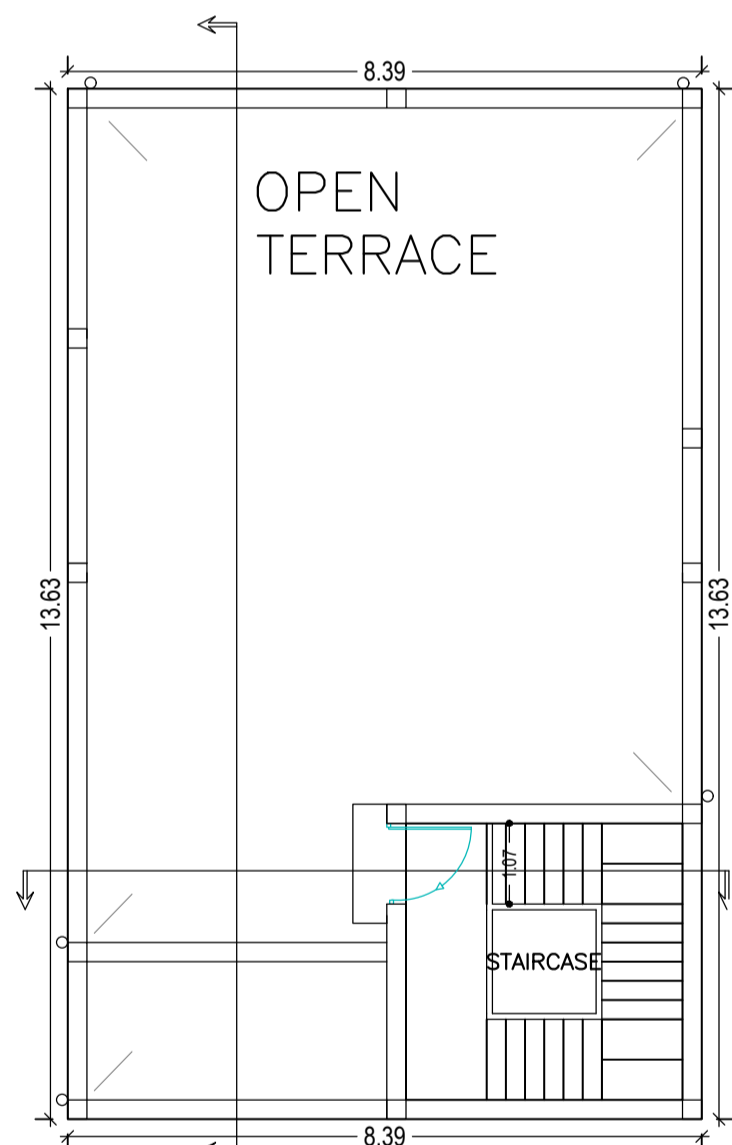

TERRACE FLOOR PLAN (SCALE 1:100)

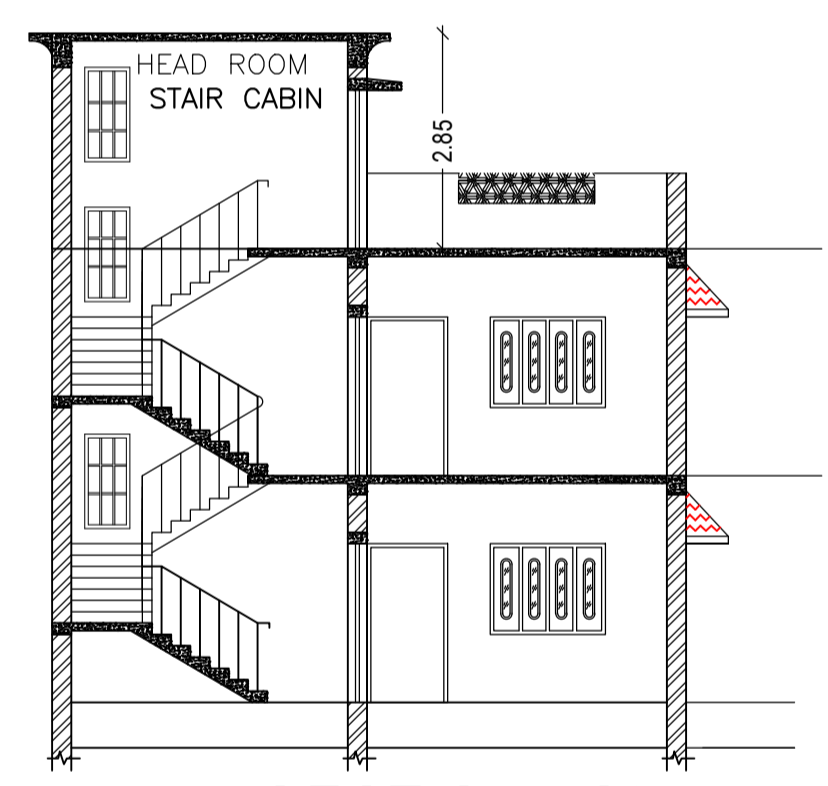

SECTION ON SCALE 1:100

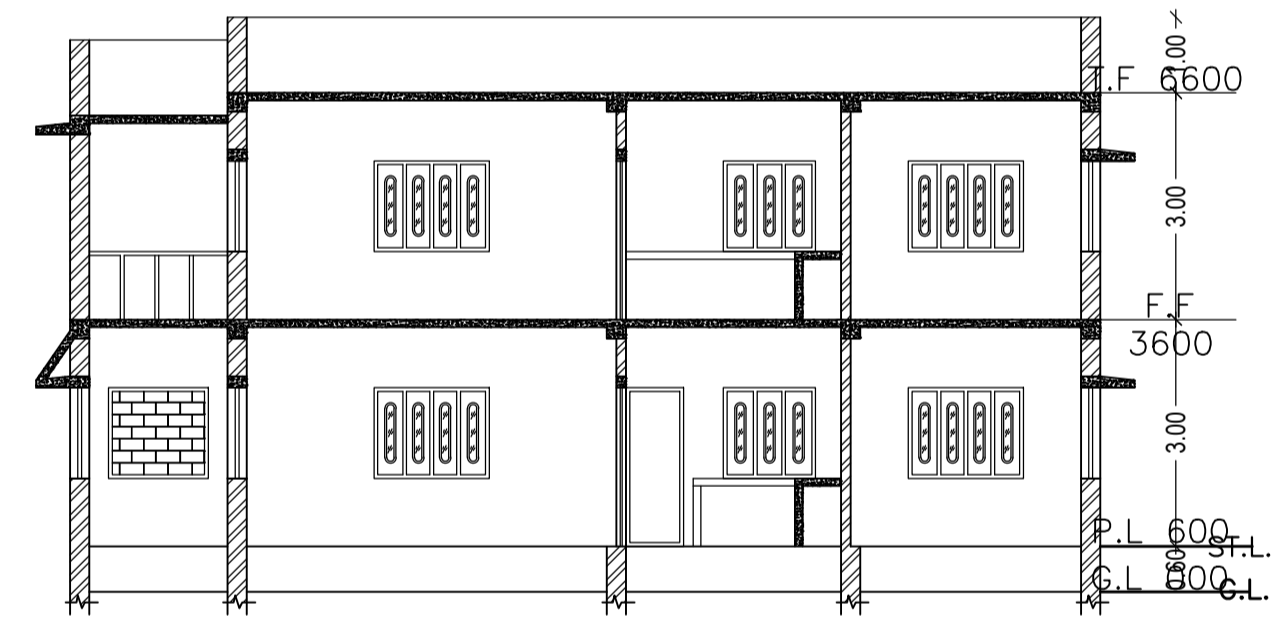

SECTION ON SCALE 1:100

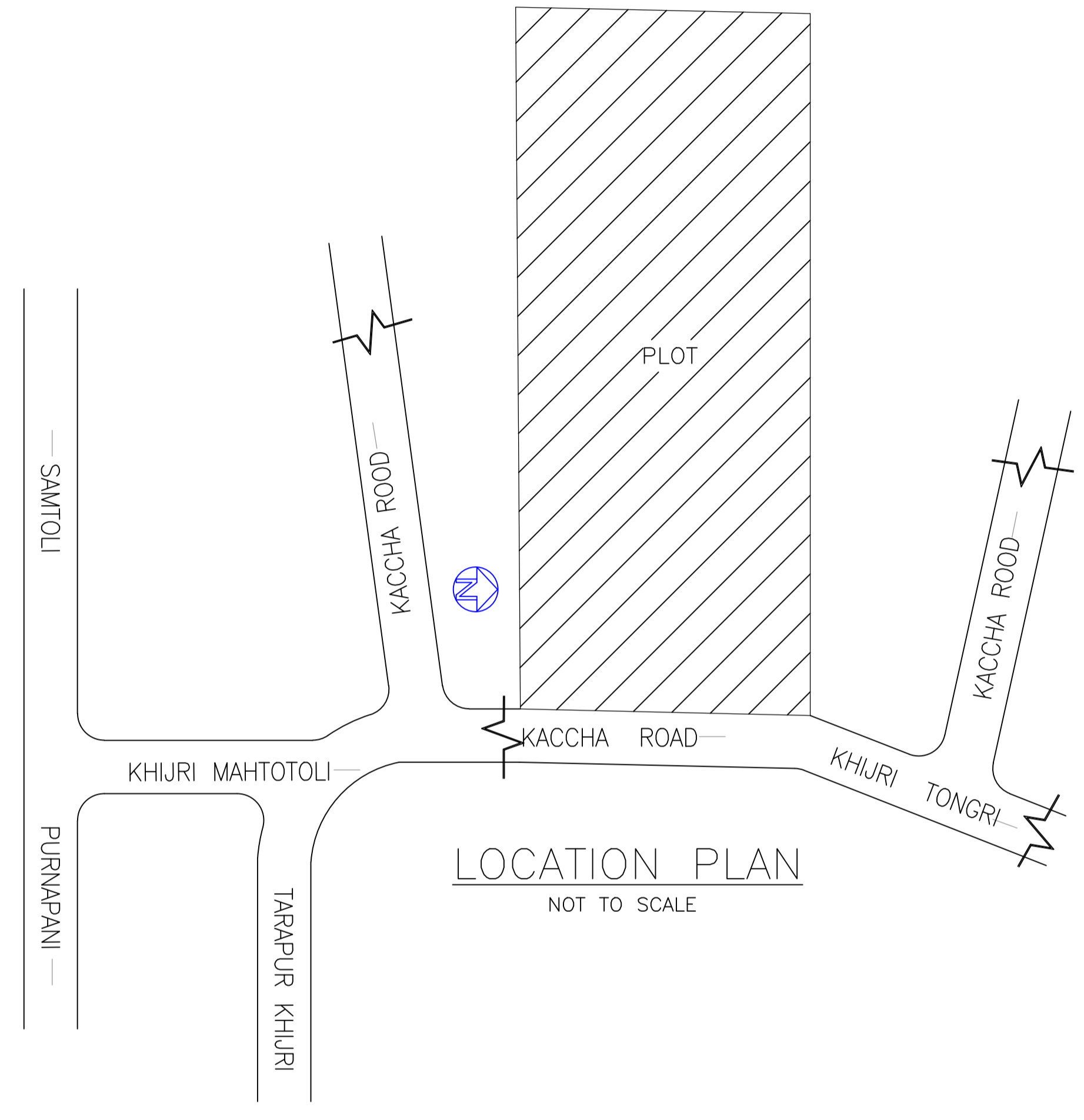

LOCATION PLAN NOT TO SCALE

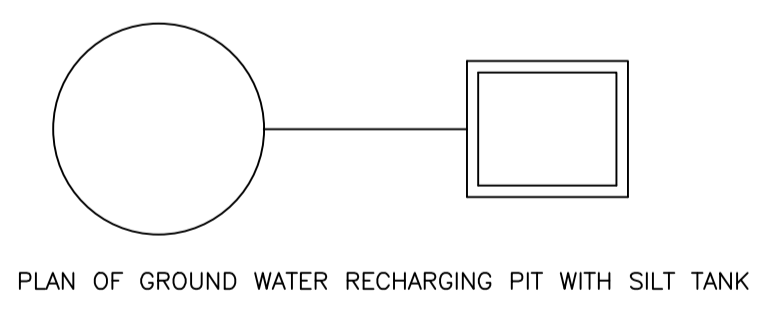

PLAN OF GROUND WATER RECHARGING PIT WITH SILT TANK

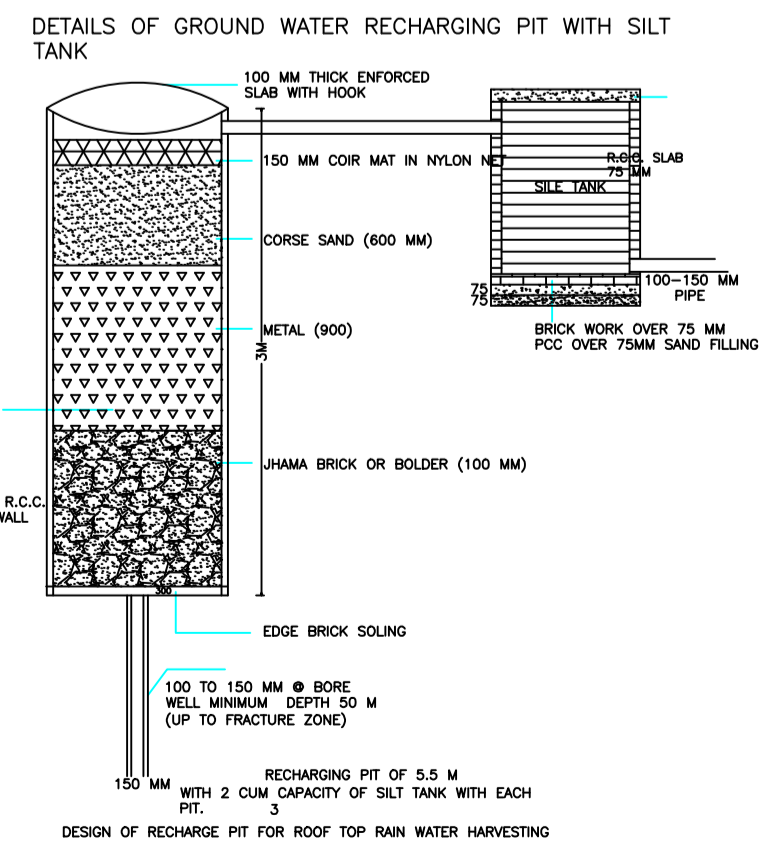

DETAILS OF GROUND WATER RECHARGING PIT WITH SILT TANK

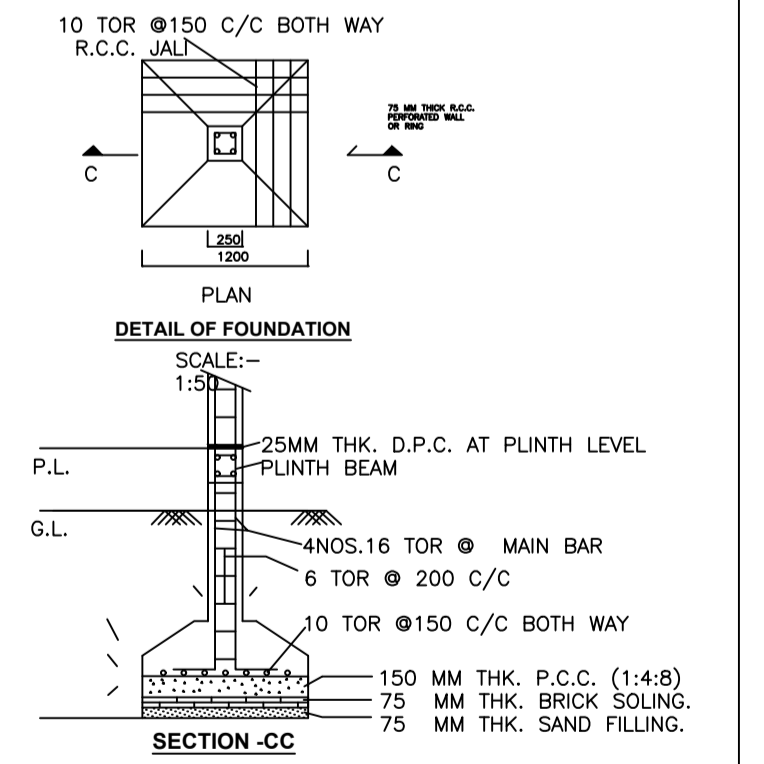

DETAIL OF FOUNDATION SCALE: 1:50

Building :A1 (BUILDING)						
Floor Name	Total Built Up Area (Sq.mt.)	Deductions (Area in Sq.mt.)	Proposed FAR Area (Sq.mt.)	Total FAR Area (Sq.mt.)	Total Consumed Additional FAR Area (Sq.mt.)	Trmt (No.)
Ground Floor	114.26	5.09	109.17	109.17	109.17	01
First Floor	114.26	5.09	109.17	109.17	109.17	00
Terrace Floor	0.00	0.00	0.00	0.00	0.00	00
Total:	228.52	10.18	218.34	218.34	218.34	01
Total Number of Same Buildings	1					
Total:	228.52	10.18	218.34	218.34	218.34	01

SCHEDULE OF DOOR:

BUILDING NAME	NAME	LENGTH	HEIGHT	NOS
A1 (BUILDING)	D2	0.76	2.10	03
A1 (BUILDING)	D1	0.91	2.10	02
A1 (BUILDING)	D	1.07	2.10	10
A1 (BUILDING)	D4	1.21	2.10	01
A1 (BUILDING)	D4	1.22	2.10	01

SCHEDULE OF WINDOW/VENTILATION:

BUILDING NAME	NAME	LENGTH	HEIGHT	NOS
A1 (BUILDING)	V	0.61	1.20	02
A1 (BUILDING)	W1	1.22	1.20	02
A1 (BUILDING)	W	1.52	1.20	13

UnitBUA Table for Building :A1 (BUILDING)

FLOOR	Name	UnitBUA Type	UnitBUA Area	Carpet Area	No. of Rooms	No. of Tenement
GROUND FLOOR PLAN	SPLIT 1	FLAT	165.89	165.09	7	1
FIRST FLOOR PLAN	SPLIT 1	FLAT	0.00	0.00	7	0
Total:	-	-	165.89	165.09	14	1

LTP NAME AND SIGNATURE	STRUCTURAL ENG'S NAME AND SIGNATURE	BUILDER NAME AND SIGNATURE
RAJESH KUMAR SINPC/DFTMN/0008/2017		

Proposal Basic Information	
Proposal File No.	SINPC/BP/0022/W06/2018
Owner Name	VILSAN KERKETTA
Khata No	19
Plot No	2727.2728
Village Name	Khijiri
Use	Residential
SubUse	Residential Bldg/Apartment

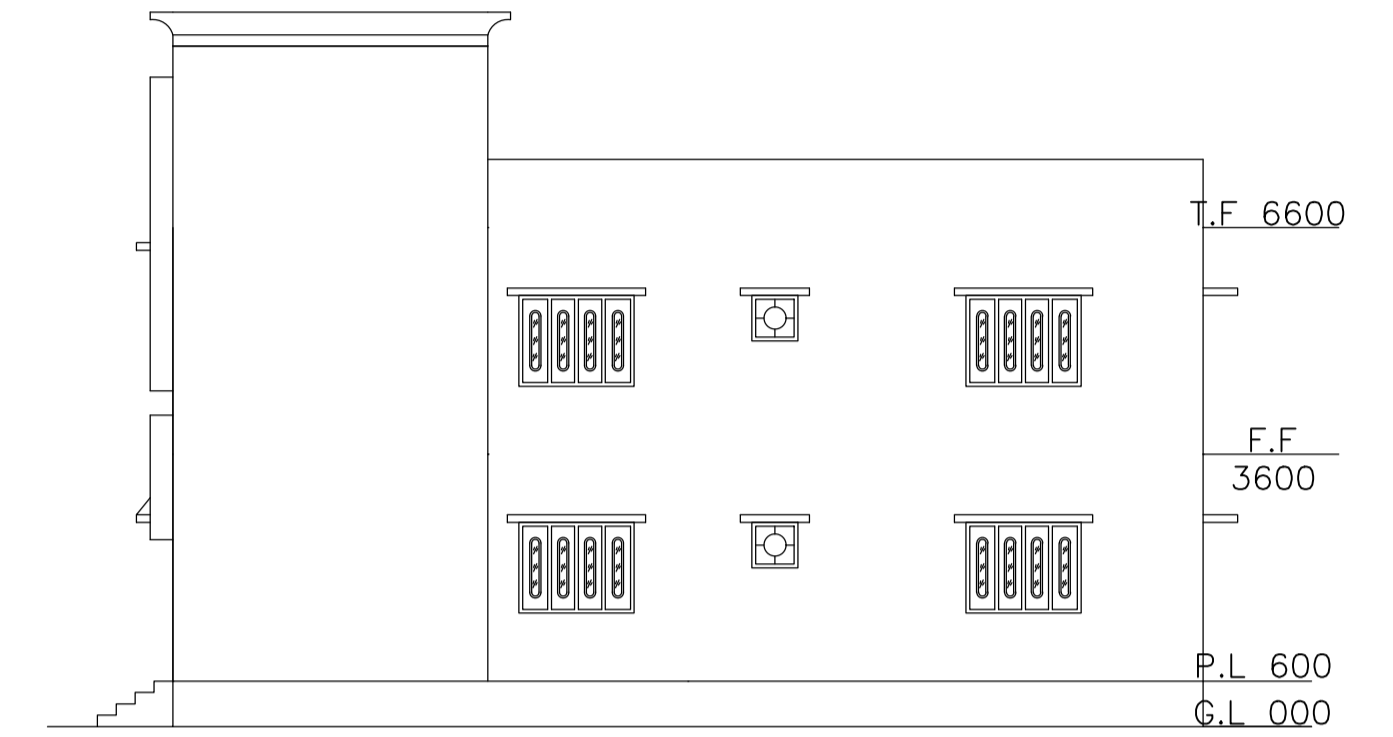

RIGHT SIDE ELEVATION
SCALE 1:100

LTP NAME AND SIGNATURE	STRUCTURAL ENG'S NAME AND SIGNATURE	BUILDER NAME AND SIGNATURE
RAJESH KUMAR SINPC/DFTMN/0008/2017		