

SITE PLAN

AREA STATEMENT SIMDEGA NAGAR PANCHAYAT		VERSION NO: 1.0.19 VERSION DATE: 13/06/2017
PROJECT DETAIL:		
Region: JHARKHAND URBAN LOCAL BODIES	Plot Use: Residential	
District: SIMDEGA	Plot SubUse: Residential Bldg/Apartment	
Authority: SIMDEGA NAGAR PANCHAYAT	PlotNearbyReligiousStructure: NA	
Inward No: SINPC/ENG/0007/16/2018	PlotSubPlot No: 642	
Application Type: General Proposal	North: -	
Project Type: Building Permission	South: -	
Nature of Development: New	East: -	
Location of Development Area: Old Area	West: -	
AREA DETAILS:		
AREA OF PLOT (Minimum)	(A)	SQ.MT. 451.08
Deduction for NetPlot Area		
Surrender Free of Cost		26.04
Total		26.04
NET AREA OF PLOT(Gross Plot Area - Deduction from Gross Plot area)	(A-Deductions)	425.04
Deduction for Balance Plot Area(from Gross Plot Area)		
Surrender Free of Cost		26.04
Common Plot		58.20
Total		84.24
BALANCE AREA OF PLOT(Net Plot Area - Recreational/Amenity space)	(A-Deductions)	366.84
PLOT AREA FOR COVERAGE(Net Plot Area)	(A-Deductions)	425.04
Plot Area for FAR (Net Plot Area + RoadWidening Area)	(A-Deductions)	451.08
COVERAGE CHECK		
Permissible Coverage area (60.00 %)		255.02
Proposed Coverage Area (34.44 %)		146.40
Total Prop. Coverage Area (34.44 %)		146.40
Balance coverage area (25.56 %)		108.62
FAR CHECK		
Perm. FAR Area (1.20)		541.30
Total Perm. FAR area		541.30
Residential FAR		146.40
Proposed FAR Area		146.40
Total Proposed FAR Area		146.40
Consumed FAR (Factor)		0.32
Balance FAR Area		394.90
BUILT UP AREA CHECK		
Total Proposed BuiltUp Area		146.40
ARCHITECT (Regd)	MD RAGIB SAYEED	
ENGINEER (Regd)		
SUPERVISOR (Regd)		
OWNER (Regd)	AVINASH KUJUR	
DEVELOPMENT AUTHORITY		LOCAL BODY

PLOT BOUNDARY	Black
ABUTTING ROAD	Green
PROPOSED CONSTRUCTION	Red
COMMON PLOT	Yellow
ROAD WIDENING AREA	Orange
EXISTING (To be retained)	Blue
EXISTING (To be demolished)	Light Blue

Buildingwise Floor FAR Details

Floor Name	Building Name A (MR AVINASH KUJUR)		Total	
	Proposed Built Up Area (Sq.mt.)	Proposed FAR Area (Sq.mt.)	Total Proposed Built Up Area (Sq.mt.)	Total FAR Area (Sq.mt.)
Ground Floor	146.40	146.40	146.40	146.40
Terrace Floor	0.00	0.00	0.00	0.00
Total :	146.40	146.40	146.40	146.40

Building USE/SUBUSE Details

Building Name	Building Use	Building SubUse	Building Structure
A (MR AVINASH KUJUR)	Residential	Residential Bldg/Apartment	Non-Highrise

FAR & Tenement Details (Table 4c-1)

Building	No. of Same Bldg	Total Built Up Area (Sq.mt.)	Proposed FAR Area (Sq.mt.) Resi.	Total FAR Area (Sq.mt.)	Total Consumed Additional FAR Area (Sq.mt.)	Tnmt (No.)
A (MR AVINASH KUJUR)	1	146.40	146.40	146.40	146.40	01
Grand Total :	1	146.40	146.40	146.40	146.40	01

LTP NAME AND SIGNATURE	STRUCTURAL ENG'S NAME AND SIGNATURE	BUILDER NAME AND SIGNATURE
MD RAGIB SAYEED SINPC/ENG/0001/2017		

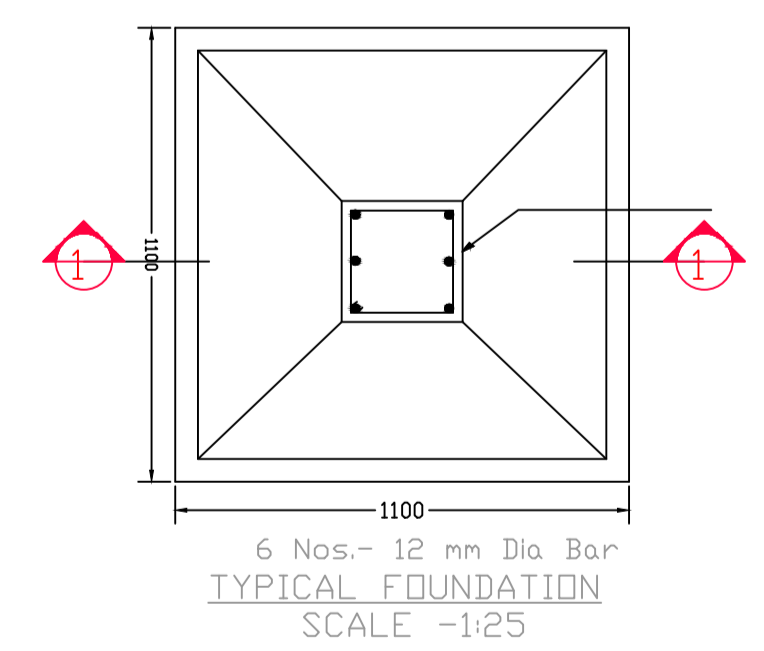
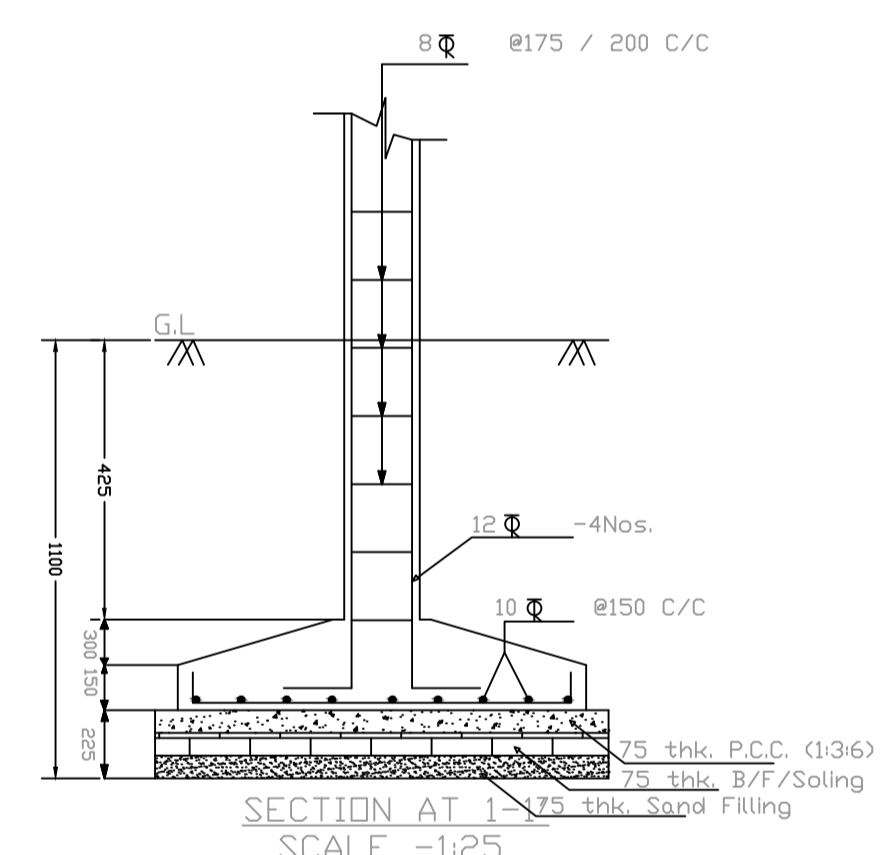
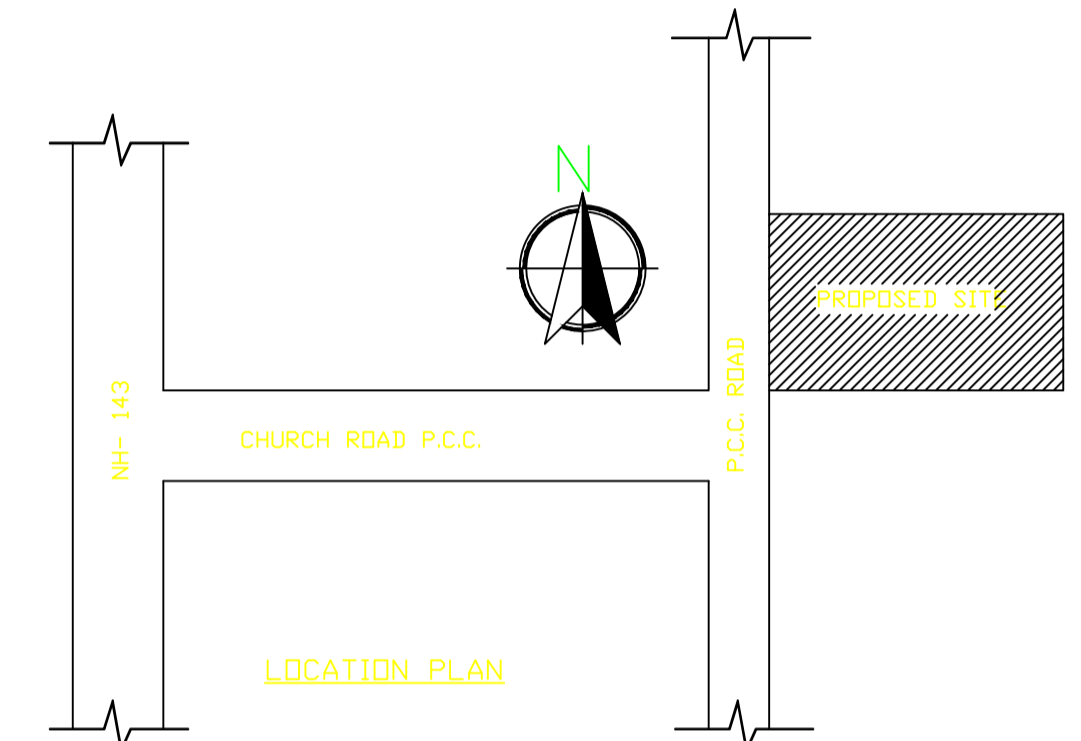
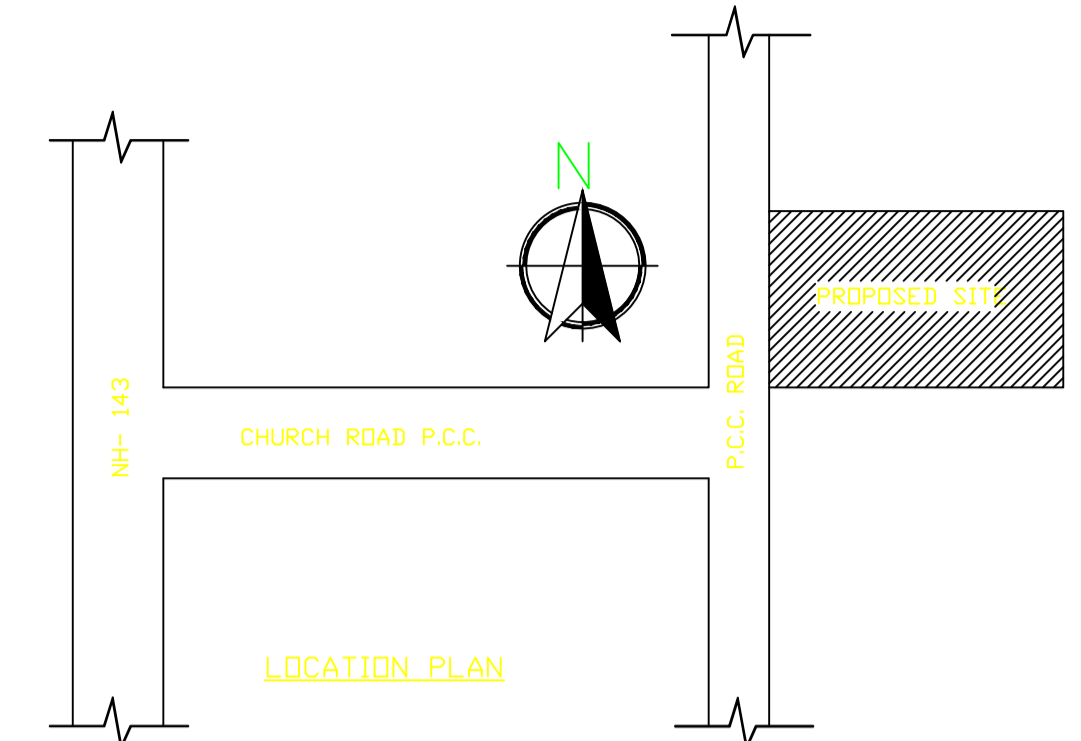
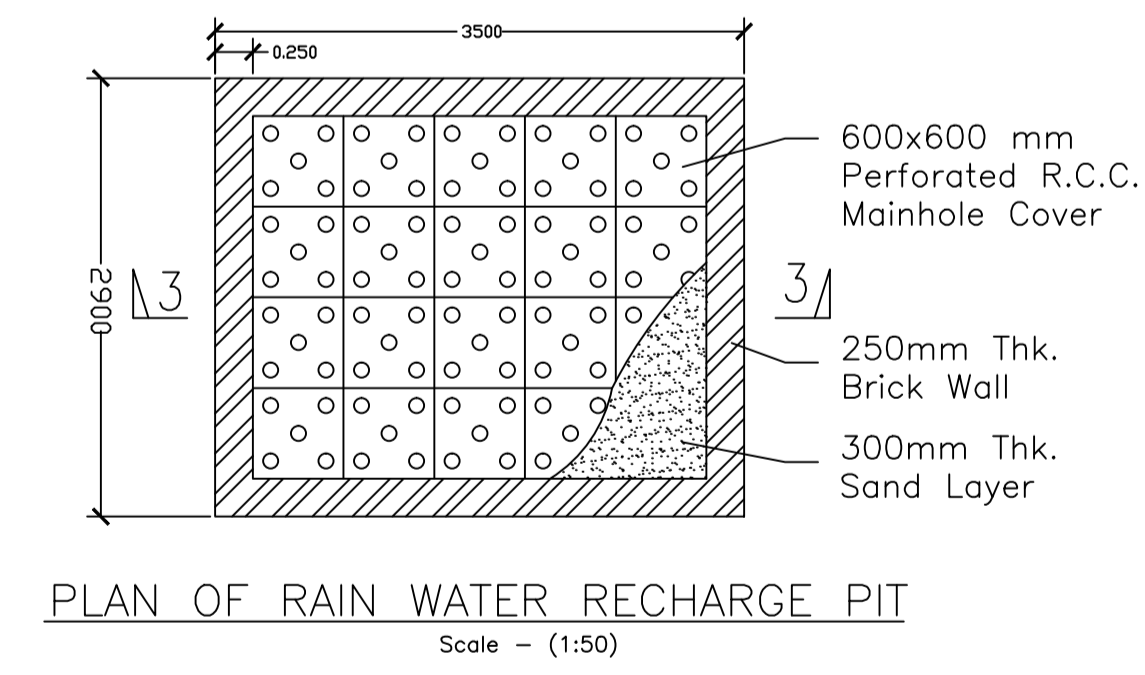
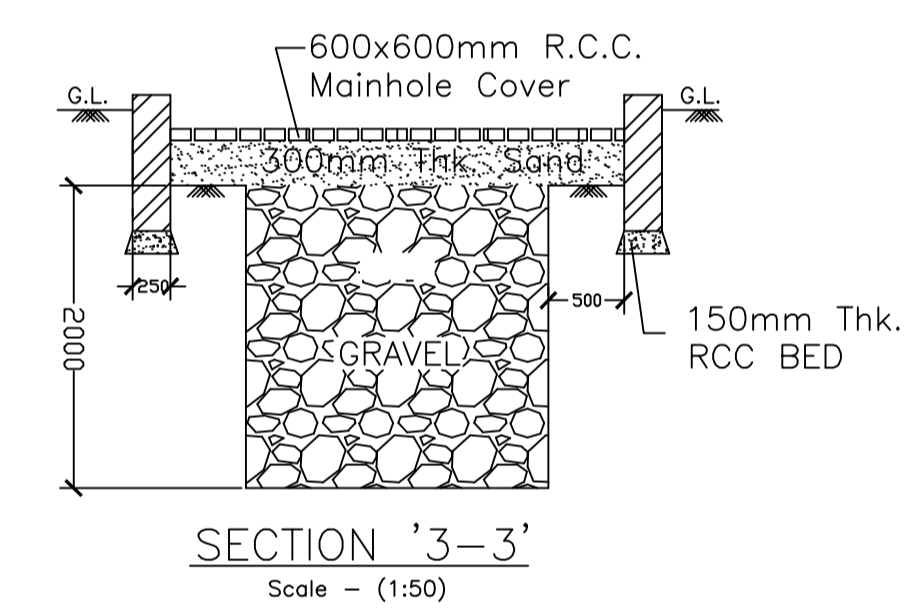
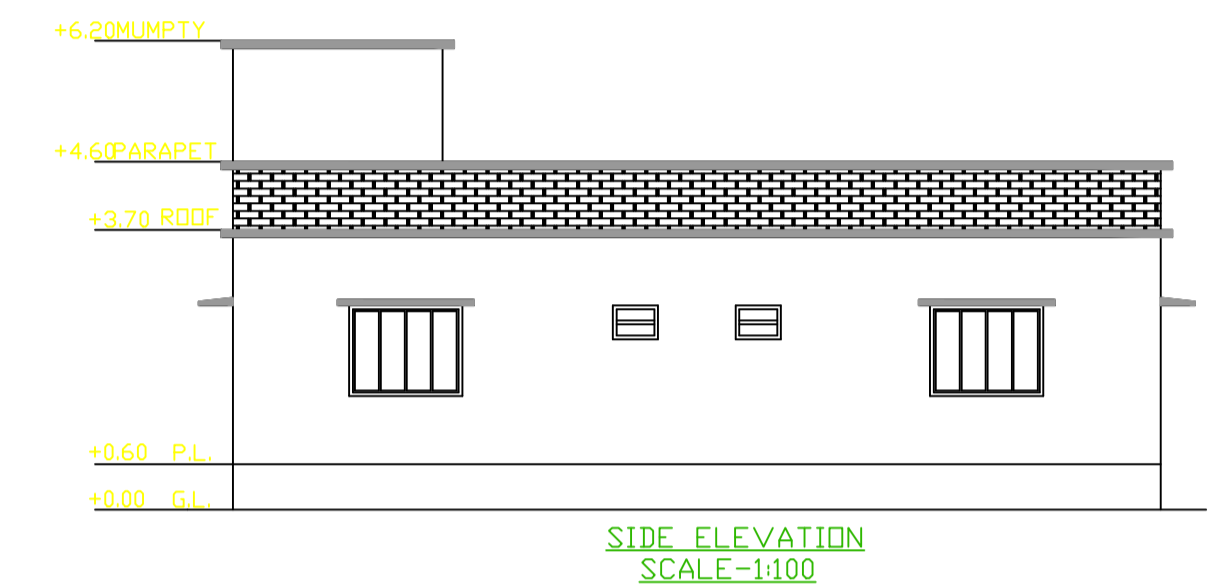
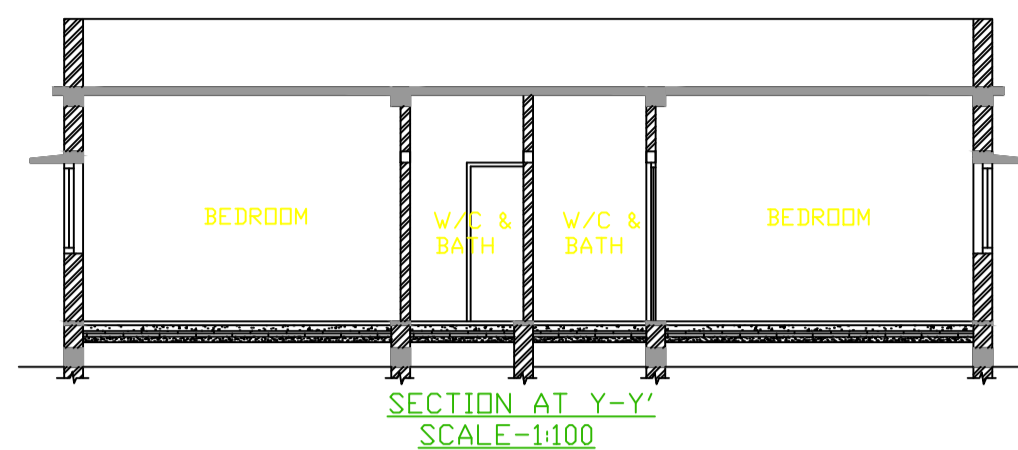
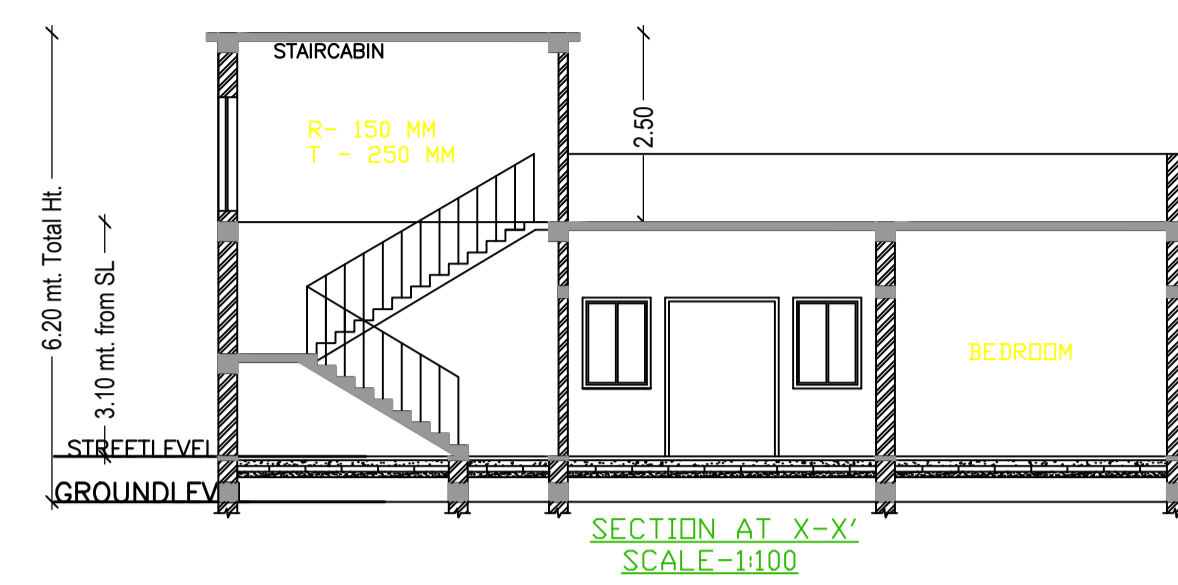
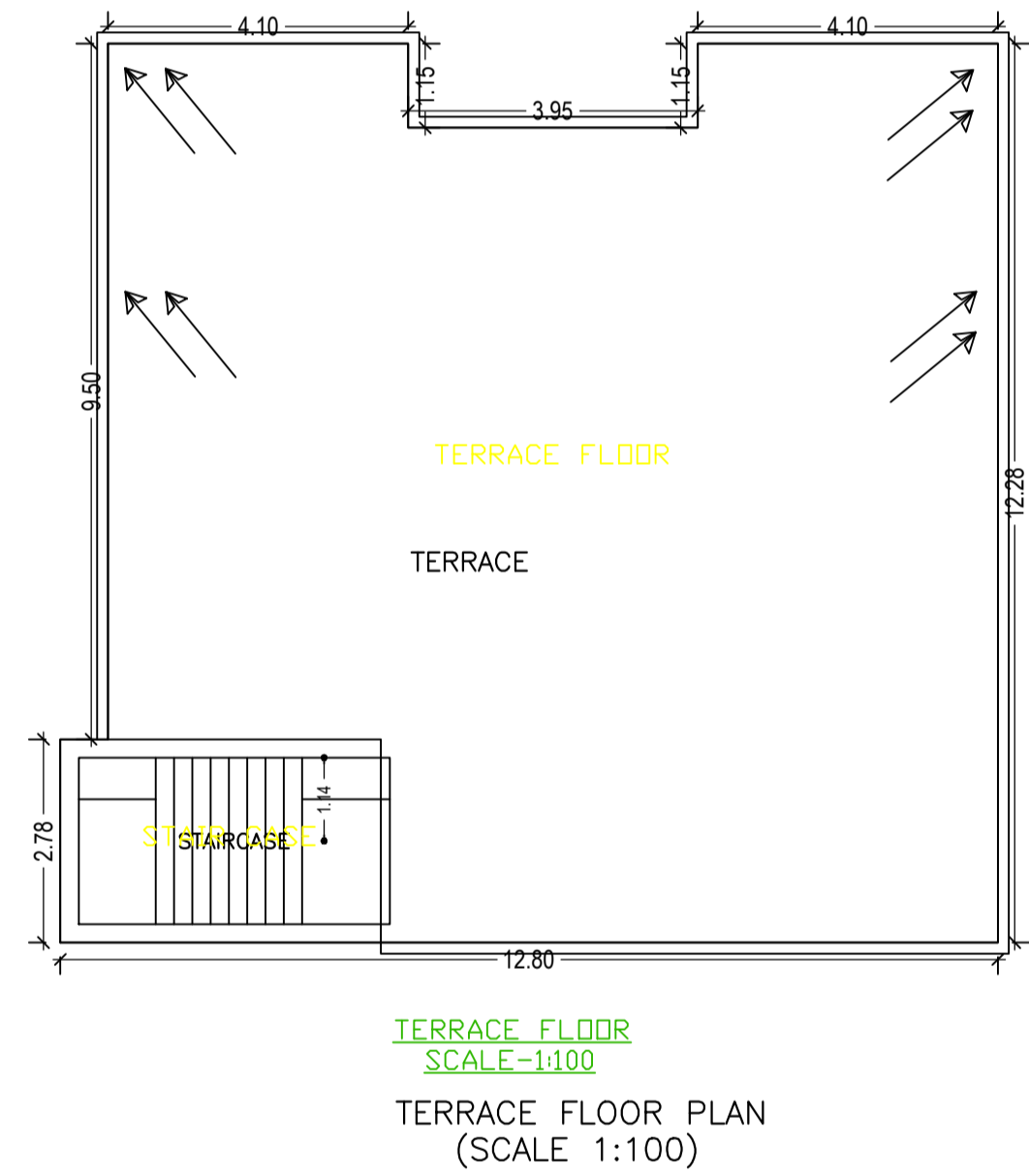
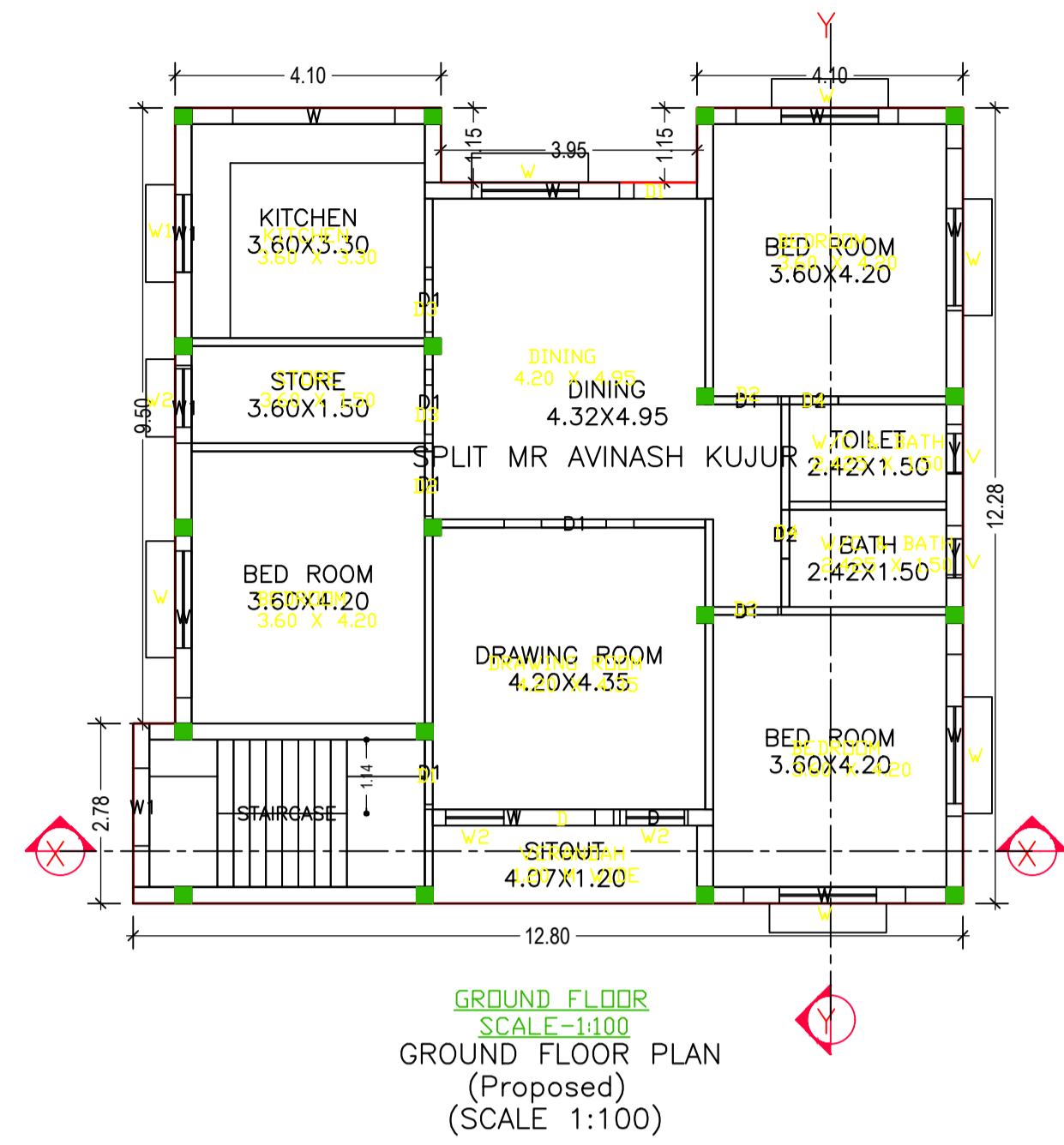

SCHEDULE OF DOOR:

BUILDING NAME	NAME	LENGTH	HEIGHT	NOS
A (MR AVINASH KUJUR)	D2	0.76	2.13	02
A (MR AVINASH KUJUR)	D1	1.00	2.13	07
A (MR AVINASH KUJUR)	D	1.05	2.13	01

SCHEDULE OF WINDOW/VENTILATION:

BUILDING NAME	NAME	LENGTH	HEIGHT	NOS
A (MR AVINASH KUJUR)	V	0.76	0.76	02
A (MR AVINASH KUJUR)	W1	1.20	2.50	03
A (MR AVINASH KUJUR)	W	2.50	2.50	08

Building :A (MR AVINASH KUJUR)

Floor Name	Total Built Up Area (Sq.mt.)	Proposed FAR Area (Sq.mt.)	Total FAR Area (Sq.mt.)	Total Consumed Additional FAR Area (Sq.mt.)	Tnmt (No.)
Ground Floor	146.40	146.40	146.40	146.40	01
Terrace Floor	0.00	0.00	0.00	0.00	00
Total :	146.40	146.40	146.40	146.40	01
Total Number of Same Buildings	1				
Total :	146.40	146.40	146.40	146.40	01

UnitBUA Table for Building :A (MR AVINASH KUJUR)

FLOOR	Name	UnitBUA Type	UnitBUA Area	Carpet Area	No. of Rooms	No. of Tenement
GROUND FLOOR PLAN	SPLIT MR AVINASH KUJUR	FLAT	123.67	117.37	10	1
Total:			123.67	117.37	10	1

LTP NAME AND SIGNATURE MD RAGIB SAYEED SINPO/ENG/0001/2017	STRUCTURAL ENG'S NAME AND SIGNATURE	BUILDER NAME AND SIGNATURE
--	-------------------------------------	----------------------------