

FAR & Tenement Details (Table 4c-1)

Building	No. of Same Bldg	Total Built Up Area (Sq.mt.)	Deductions (Area in Sq.mt.)		Proposed FAR Area (Sq.mt.)	Total FAR Area (Sq.mt.)	Total Consumed Additional FAR Area (Sq.mt.)	Trmnt (No.)
			Void	Resi.				
A1 (BUILDING)	1	236.71	15.96	-	220.75	220.75	220.75	02
Grand Total :	1	236.71	15.96	-	220.75	220.75	220.75	02

Proposal Basic Information

Proposal File No.	SINPC/BP/0060/W07/2018
Owner Name	ABHA RANI LAKRA
Khata No	134
Plot No	127
Village Name	Khijri
Use	Residential
SubUse	Residential Bldg/Apartment

Required Parking (Table 7a)

Building Name	Type	SubUse	Area (Sq.mt.)	Units		Car		Visitors Car		TwoWheeler	
				Reqd.	Prop.	Reqd./Unit	Prop.	Reqd./Unit	Prop.	Reqd./Unit	Prop.
A1 (BUILDING)	Residential	Residential Bldg/Apartment	> 0	1	2.00	1	2	-	-	-	-
			> 0	1	2.00	-	-	-	-	1	2
			> 0	1	2.00	-	-	1	1	-	-
Total :			-	-	-	-	2	3	-	1	2

Parking Check (Table 7b)

Vehicle Type	Reqd.		Prop.	
	No.	Area	No.	Area
Car	-	-	3	37.50
Total Car	2	25.00	3	37.50
Visitor's Car Parking	1	12.50	2	25.00
TwoWheeler	2	4.00	6	12.00
Other Parking	-	-	-	96.03
Total		41.50		172.53

AREA STATEMENT SIMDEGA NAGAR PANCHAYAT

VERSION NO: 1.0.29

VERSION DATE: 30/06/2018

PROJECT DETAIL:

Region: JHARKHAND URBAN LOCAL BODIES

District: SIMDEGA

Authority: SIMDEGA NAGAR PANCHAYAT

Inward No: SINPC/BP/0060/W07/2018

Application Type: General Proposal

Project Type: Building Permission

Nature of Development: New

Location of Development Area: New Area

AREA OF PLOT (Minimum)

Deduction for NetPlot Area

Road Widening Area

NET AREA OF PLOT (Gross Plot Area - Deduction from Gross Plot Area)

Deduction for Balance Plot Area (from Gross Plot Area)

Road Widening Area

Common Plot

BALANCE AREA OF PLOT (Net Plot Area - Recreational/Amenity space)

PLOT AREA FOR COVERAGE (Net Plot Area)

Plot Area for FAR (Net Plot Area + Road Widening Area)

COVERAGE CHECK

Permissible Coverage area (60.00 %)

Proposed Coverage Area (31.27 %)

Total Prop. Coverage Area (31.27 %)

Balance coverage area (28.73 %)

FAR CHECK

Perm. FAR Area (1.50)

Total Perm. FAR area

Residential FAR

Proposed FAR Area

Total Proposed FAR Area

Consumed FAR (Factor)

Balance FAR Area

BUILT UP AREA CHECK

Total Proposed BuiltUp Area

ARCHITECT (Regd)

ENGINEER (Regd)

SUPERVISOR (Regd)

OWNER (Regd)

DEVELOPMENT AUTHORITY

LOCAL BODY

COLOR INDEX

PLOT BOUNDARY

ABUTTING ROAD

PROPOSED CONSTRUCTION

COMMON PLOT

ROAD WIDENING AREA

EXISTING (To be retained)

EXISTING (To be demolished)

Buildingwise Floor FAR Details

Floor Name	Building Name		Total	
	Proposed Built Up Area (Sq.mt.)	Proposed FAR Area (Sq.mt.)	Total Proposed Built Up Area (Sq.mt.)	Total FAR Area (Sq.mt.)
Ground Floor	118.36	112.99	118.36	112.99
First Floor	118.35	107.76	118.35	107.76
Terrace Floor	0.00	0.00	0.00	0.00
Total :	236.71	220.75	236.71	220.75

Building USE/SUBUSE Details

Building Name	Building Use	Building SubUse	Building Structure
A1 (BUILDING)	Residential	Residential Bldg/Apartment	Non-Highrise

LTP NAME AND SIGNATURE	STRUCTURAL ENG'S NAME AND SIGNATURE	BUILDER NAME AND SIGNATURE
RAJESH KUMAR SINPC/DFTMN/0006/2017		

Proposal Basic Information	
Proposal File No.	SINPC/BP/0060/W07/2018
Owner Name	ABHA RANI LAKRA
Khata No	134
Plot No	127
Village Name	Khijiri
Use	Residential
SubUse	Residential Bldg/Apartment

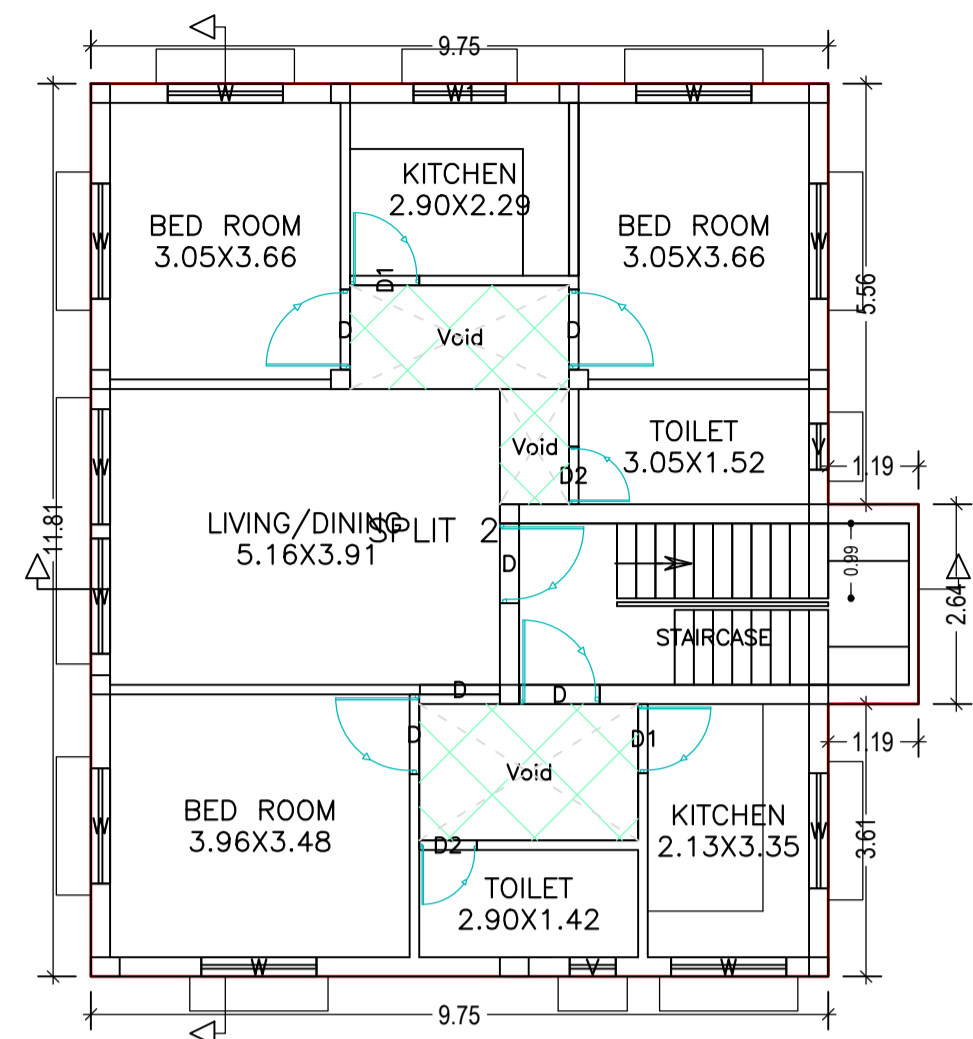
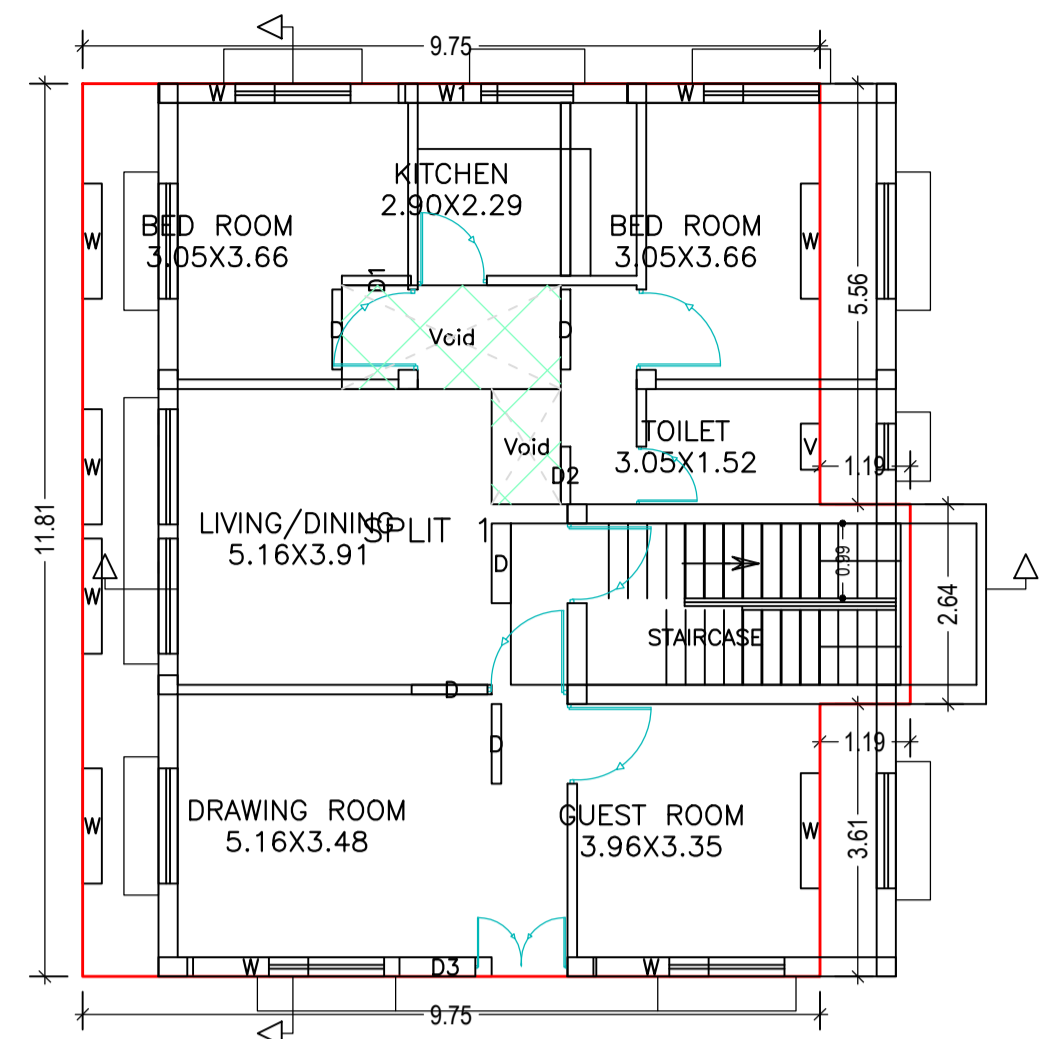

FIRST FLOOR PLAN (Proposed) SCALE 1:100

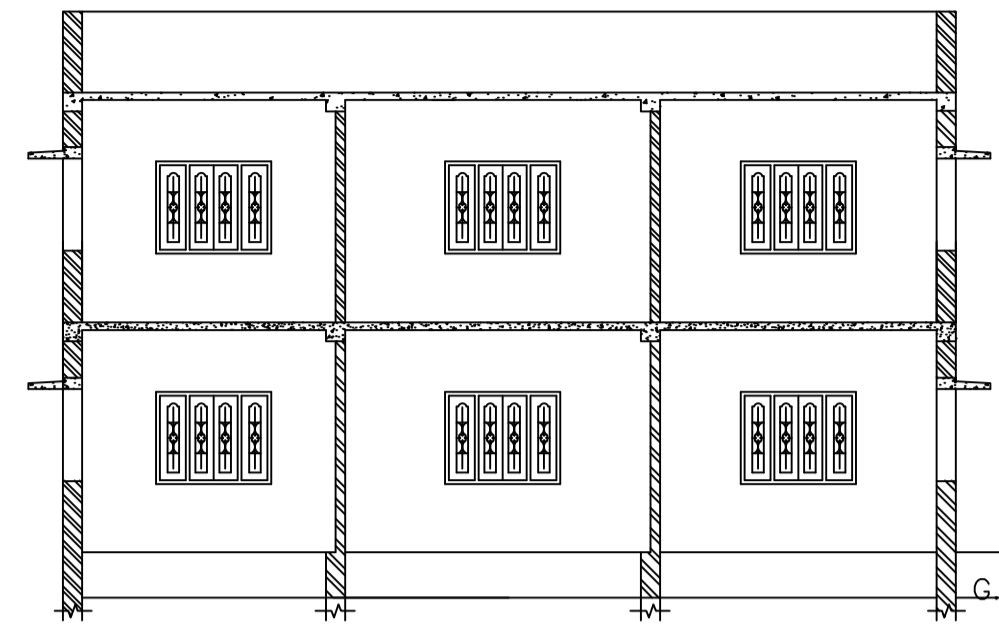

SECTION AT X-X SCALE 1:100

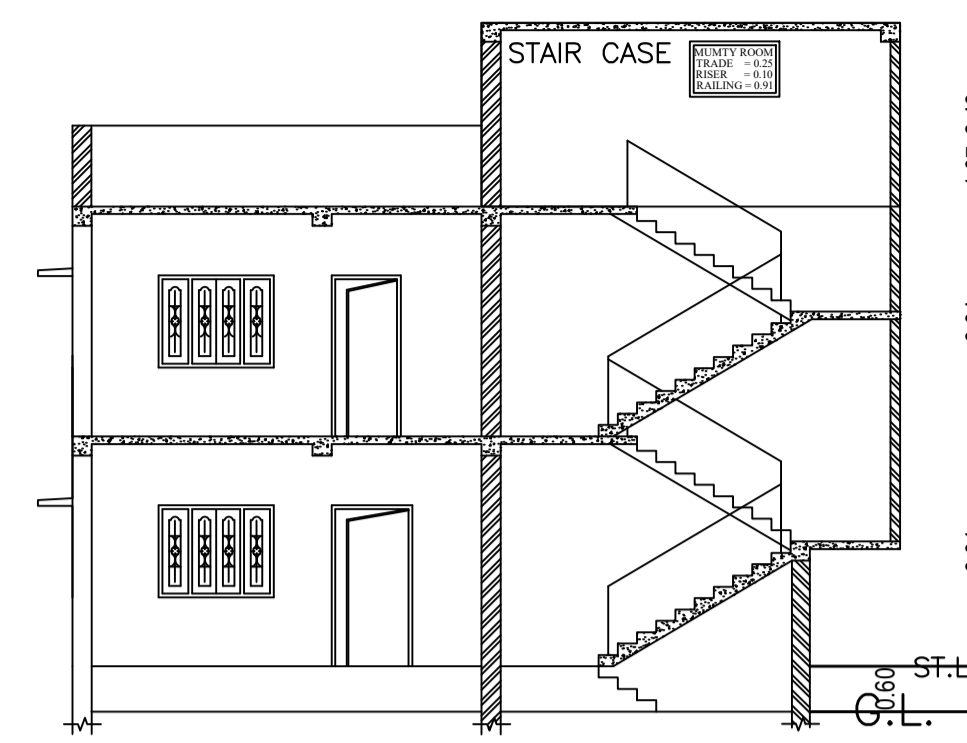

SECTION AT Y-Y SCALE 1:100

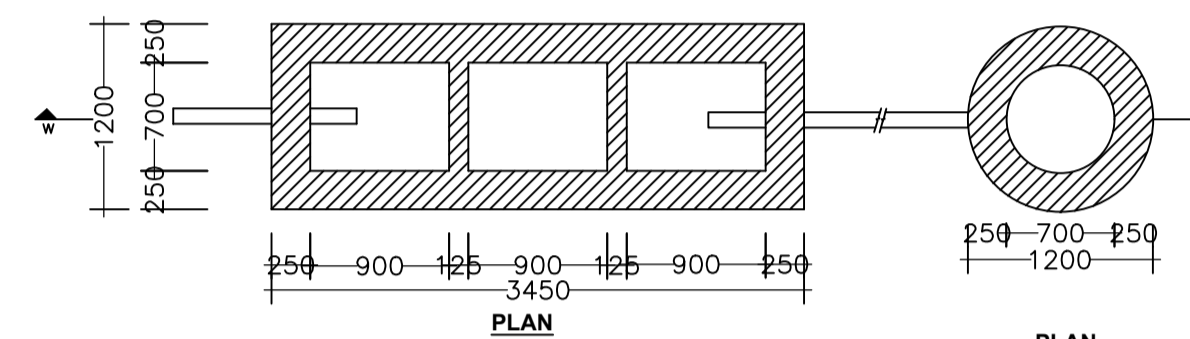

DETAIL OF SEPTIC TANK & SOAKPIT. SCALE 1:50

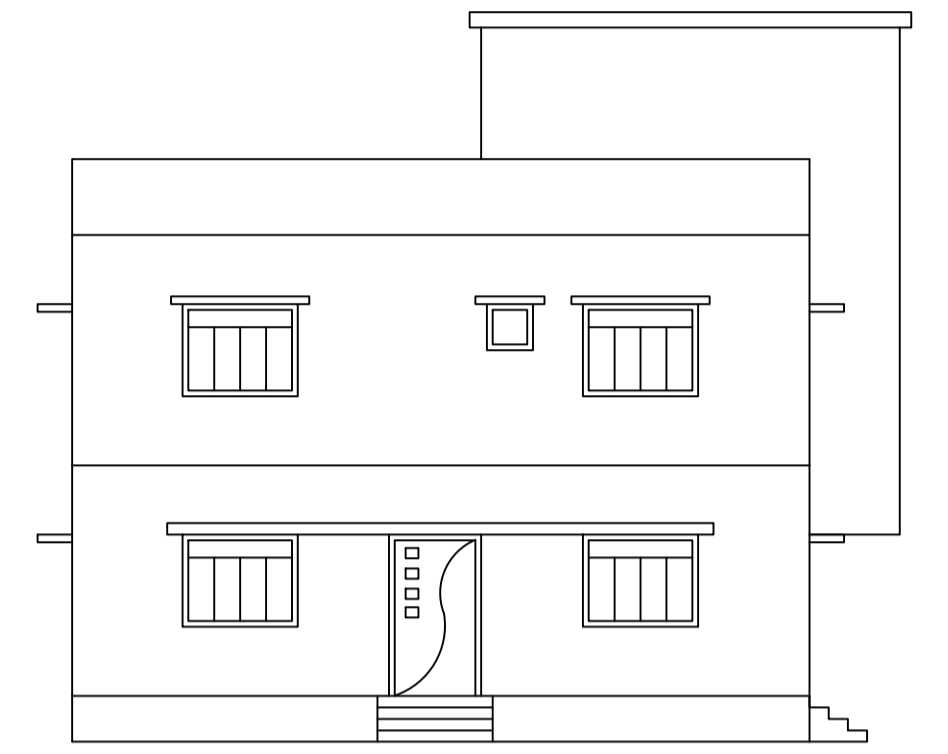

FRONT ELEVATION SCALE 1:100

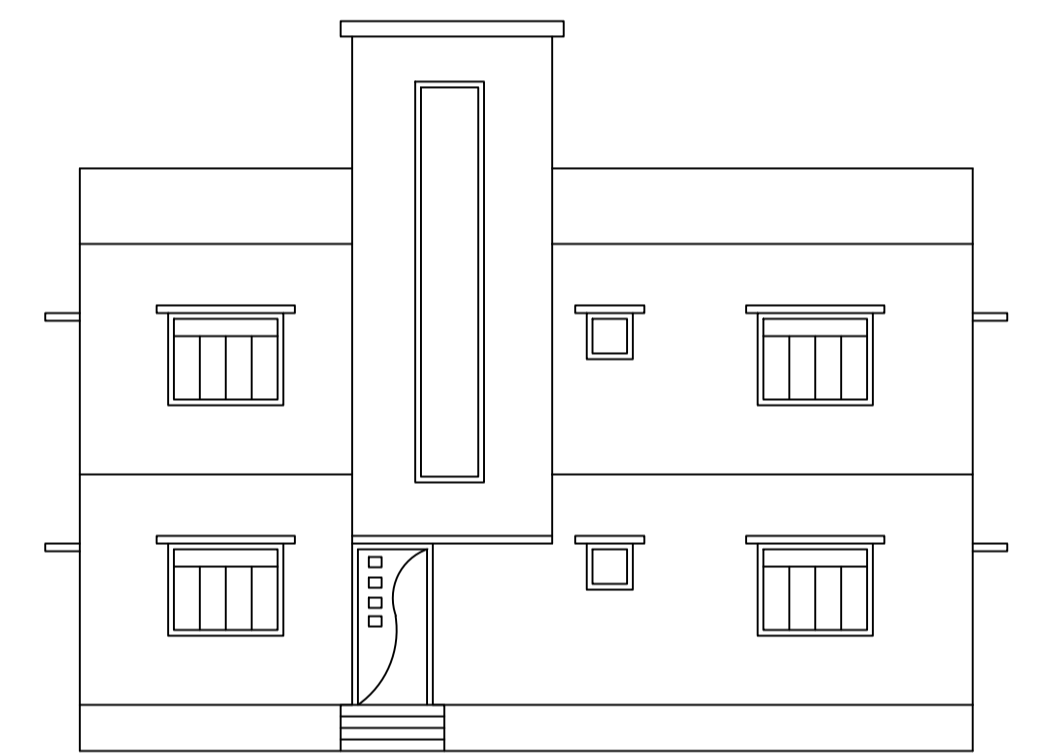

RIGHT SIDE ELEVATION SCALE 1:100

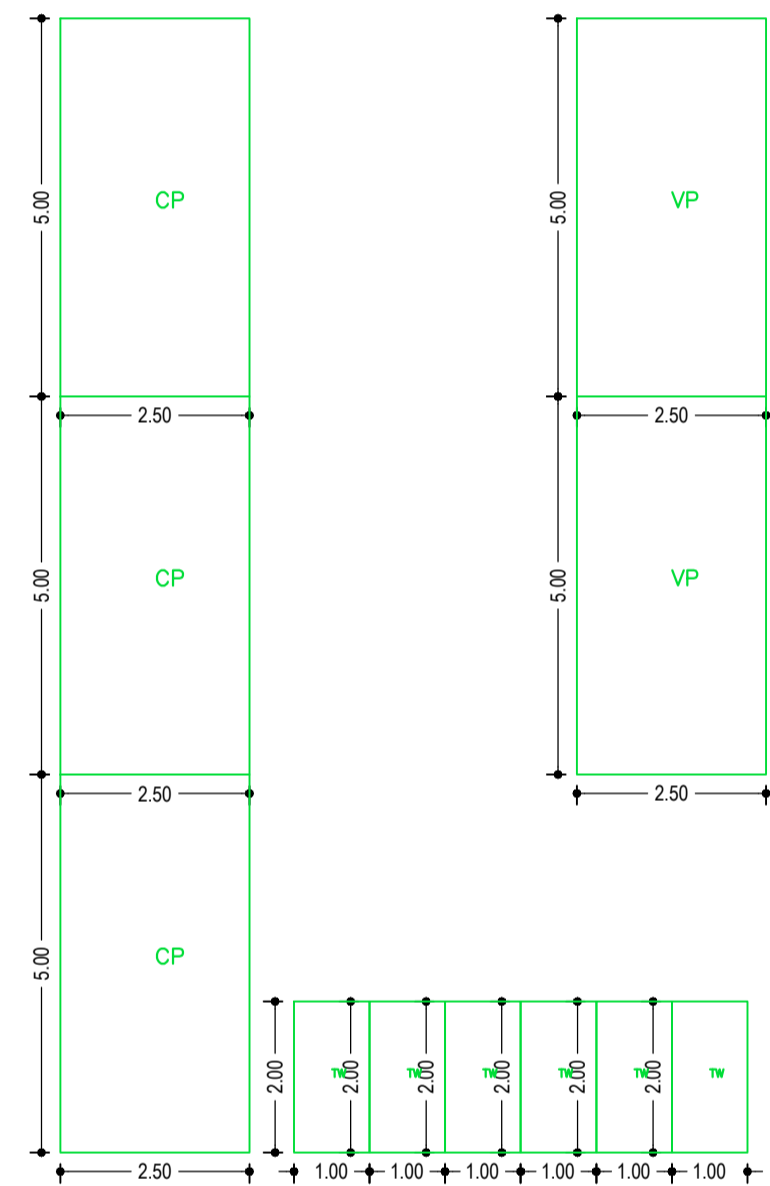

GROUND FLOOR PLAN (Proposed) SCALE 1:100

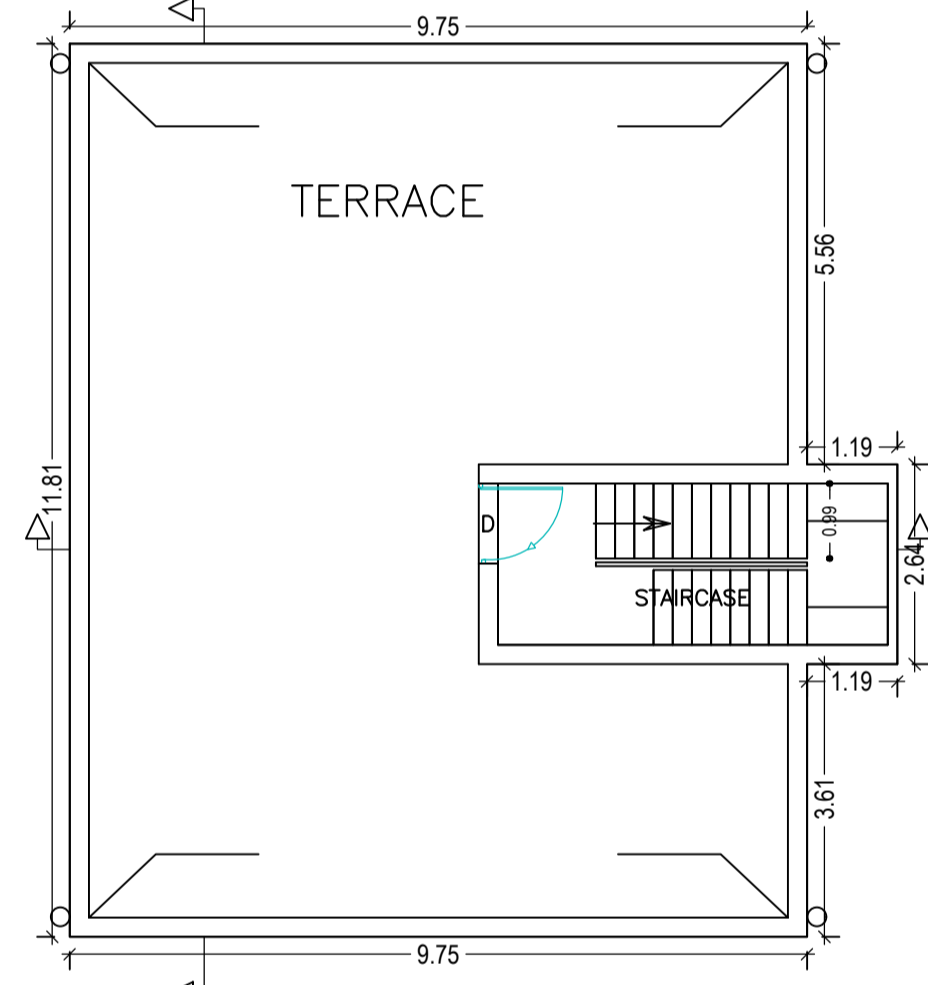

TERRACE FLOOR PLAN (Proposed) SCALE 1:100

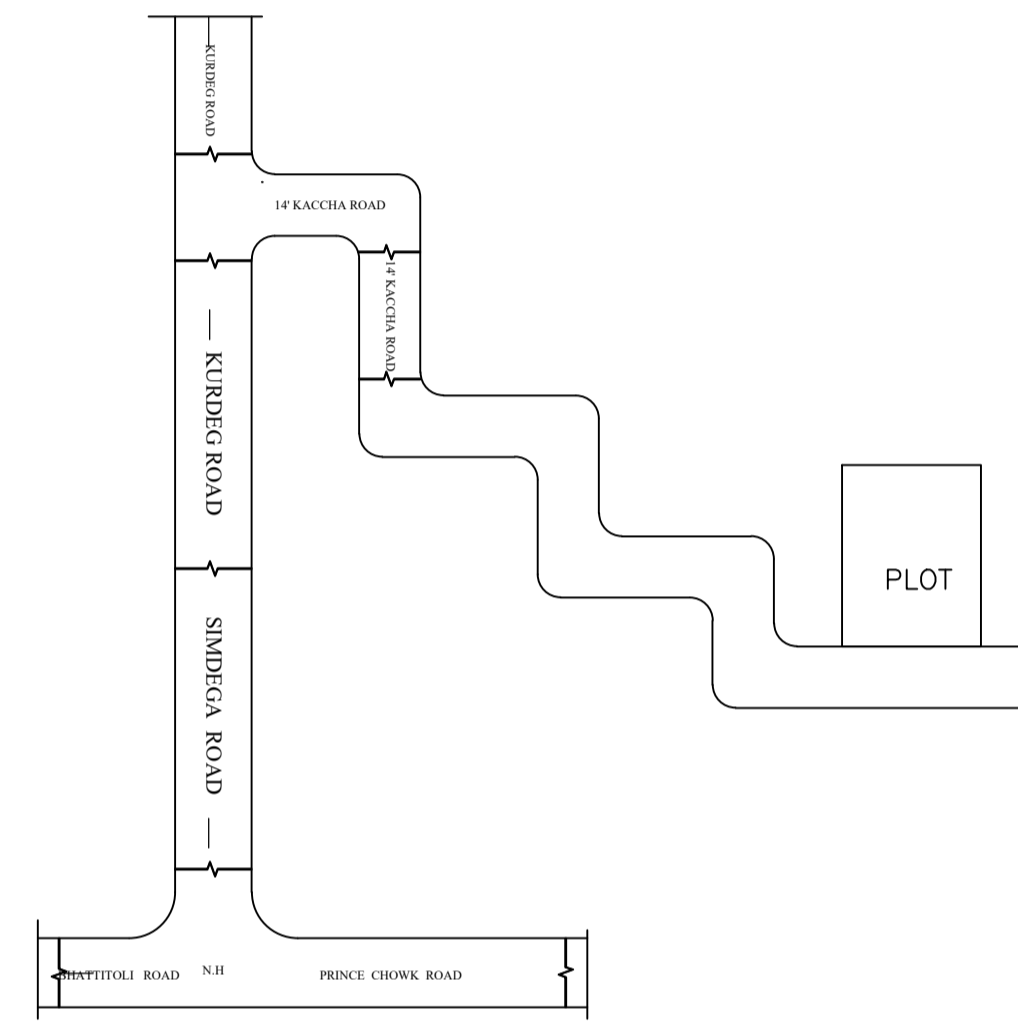

SITE LOCATION PLAN NOT TO SCALE

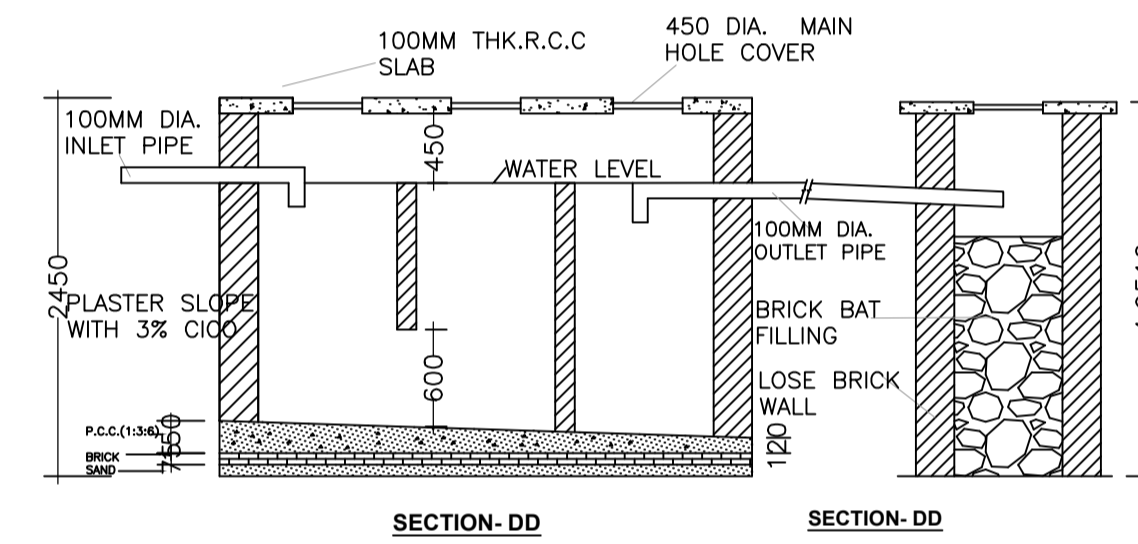

SECTION-DD

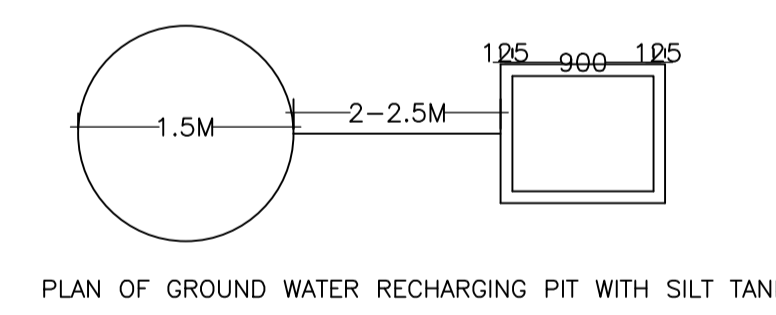

PLAN OF GROUND WATER RECHARGING PIT WITH SILT TANK

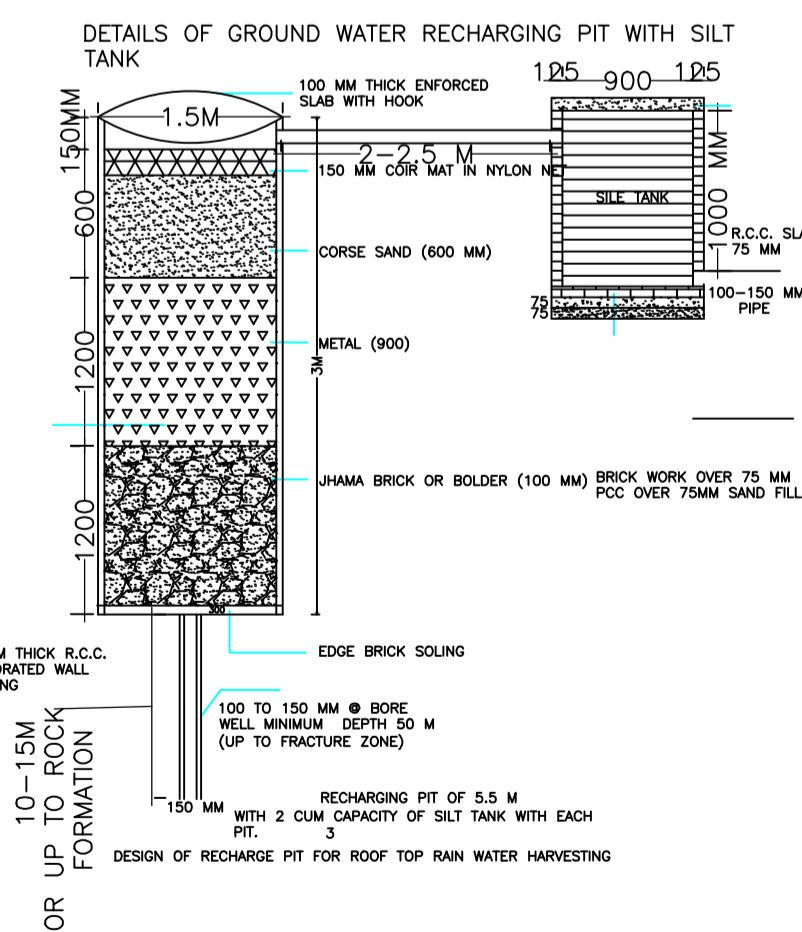

DETAILS OF GROUND WATER RECHARGING PIT WITH SILT TANK

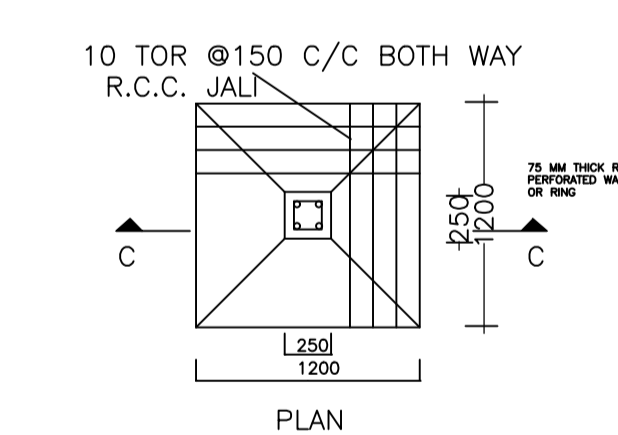

DETAIL OF FOUNDATION SCALE: 1:50

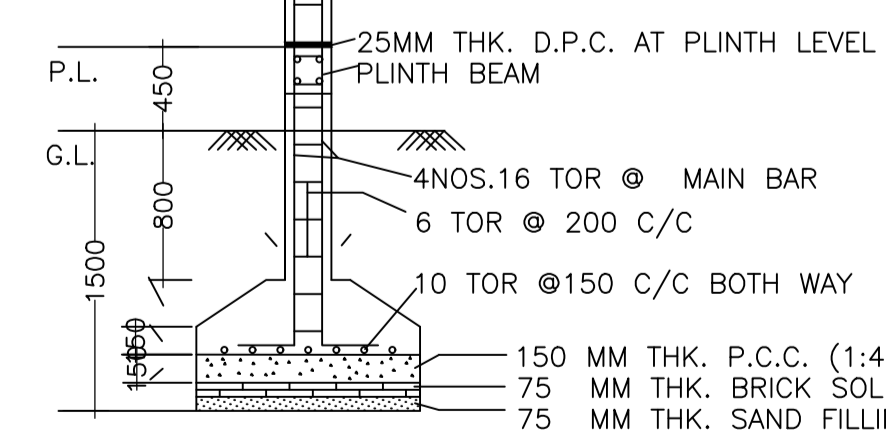

SECTION-CC

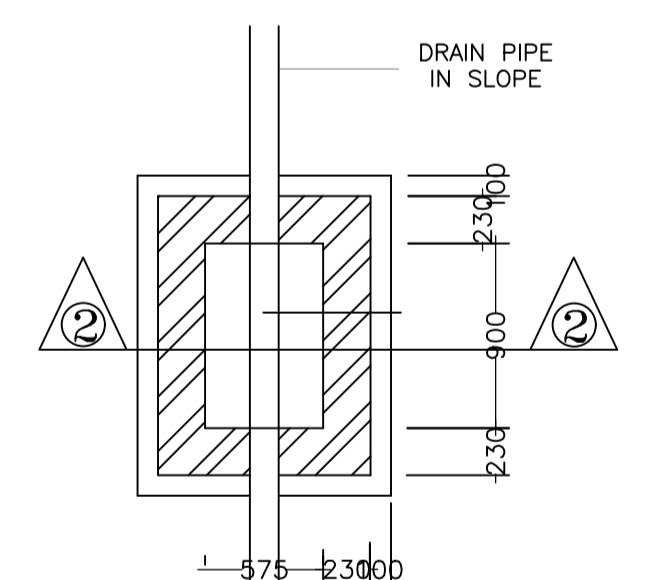

PLAN I.C. DETAILS R.C.C. COVER

Building :A1 (BUILDING)

Floor Name	Total Built Up Area (Sq.mt.)	Deductions (Area in Sq.mt.)	Proposed FAR Area (Sq.mt.)	Total FAR Area (Sq.mt.)	Total Consumed Additional FAR Area (Sq.mt.)	Trmt (No.)
Ground Floor	118.36	5.37	112.99	112.99	112.99	01
First Floor	118.35	10.59	107.76	107.76	107.76	01
Terrace Floor	0.00	0.00	0.00	0.00	0.00	00
Total:	236.71	15.96	220.75	220.75	220.75	02
Total Number of Same Buildings	1					
Total:	236.71	15.96	220.75	220.75	220.75	02

SCHEDULE OF DOOR:

BUILDING NAME	NAME	LENGTH	HEIGHT	NOS
A1 (BUILDING)	D2	0.76	2.10	03
A1 (BUILDING)	D1	0.91	2.10	03
A1 (BUILDING)	D	1.06	2.10	10
A1 (BUILDING)	D3	1.22	2.10	01

SCHEDULE OF WINDOW/VENTILATION:

BUILDING NAME	NAME	LENGTH	HEIGHT	NOS
A1 (BUILDING)	V	0.61	1.20	03
A1 (BUILDING)	W1	1.22	1.20	02
A1 (BUILDING)	W	1.52	1.20	20

UnitBUA Table for Building :A1 (BUILDING)

FLOOR	Name	UnitBUA Type	UnitBUA Area	Carpet Area	No. of Rooms	No. of Tenement
GROUND FLOOR PLAN	SPLIT 1	FLAT	88.34	88.04	7	1
FIRST FLOOR PLAN	SPLIT 2	FLAT	83.11	82.82	8	1
Total:	-	-	171.45	170.86	15	2

LTP NAME AND SIGNATURE	STRUCTURAL ENG'S NAME AND SIGNATURE	BUILDER NAME AND SIGNATURE
RAJESH KUMAR SINPC/DFTMN/0006/2017		