

SITE PLAN
SCALE 1-100

SITE PLAN

FAR & Tenement Details (Table 4c-1)

Building	No. of Same Bldg	Total Built Up Area (Sq.mt.)	Proposed FAR Area (Sq.mt.)	Total FAR Area (Sq.mt.)	Total Consumed Additional FAR Area (Sq.mt.)	Tnmt (No.)
A (BUILDING)	1	260.50	260.50	260.50	260.50	02
Grand Total :	1	260.50	260.50	260.50	260.50	02

Proposal Basic Information

Proposal File No.	SINPC/BP/0065/W16/2018
Owner Name	MERKHA PUNP TIGGA
Khata No	75
Plot No	758
Village Name	Simdega
Use	Residential
SubUse	Residential Bldg/Apartment

Required Parking (Table 7a)

Building Name	Type	SubUse	Area (Sq.mt.)	Units		Car		Visitors Car		TwoWheeler	
				Reqd.	Prop.	Reqd./Unit	Reqd.	Prop.	Reqd./Unit	Reqd.	Prop.
A (BUILDING)	Residential	Residential Bldg/Apartment	> 0	1	2.00	1	2	-	-	-	-
			> 0	1	2.00	-	-	-	-	1	2
			> 0	1	2.00	-	-	1	1	-	-
Total :			-	-	-	2	3	-	1	2	6

Parking Check (Table 7b)

Vehicle Type	Reqd.		Prop.	
	No.	Area	No.	Area
Car	-	-	3	37.50
Total Car	2	25.00	3	37.50
Visitor's Car Parking	1	12.50	2	25.00
TwoWheeler	2	4.00	6	12.00
Other Parking	-	-	-	108.47
Total	-	41.50	-	182.97

AREA STATEMENT SIMDEGA NAGAR PANCHAYAT	VERSION NO: 1.0.28
PROJECT DETAIL:	VERSION DATE: 30/06/2018
Region: JHARKHAND URBAN LOCAL BODIES	Plot Use: Residential
District: SIMDEGA	Plot SubUse: Residential Bldg/Apartment
Authority: SIMDEGA NAGAR PANCHAYAT	PlotNearby/ReligiousStructure: NA
Inward No: SINPC/BP/0065/W16/2018	PlotSubPlot No: 758
Application Type: General Proposal	North: -
Project Type: Building Permission	South: -
Nature of Development: New	East: -
Location of Development Area: New Area	West: -
AREA DETAILS:	SQ.MT.
AREA OF PLOT (Minimum)	(A) 445.05
Deduction for NetPlot Area	
Surrender Free of Cost	21.88
Total	21.88
NET AREA OF PLOT(Gross Plot Area - Deduction from Gross Plot area)	(A-Deductions) 423.16
Deduction for Balance Plot Area(from Gross Plot Area)	
Surrender Free of Cost	21.88
Common Plot	106.89
Total	128.78
BALANCE AREA OF PLOT(Net Plot Area - Recreational/Amenity space)	(A-Deductions) 316.27
PLOT AREA FOR COVERAGE(Net Plot Area)	(A-Deductions) 423.16
Plot Area for FAR (Net Plot Area + RoadWidening Area)	(A-Deductions) 445.05
COVERAGE CHECK	
Permissible Coverage area (60.00 %)	253.90
Proposed Coverage Area (30.78 %)	130.25
Total Prop. Coverage Area (30.78 %)	130.25
Balance coverage area (29.22 %)	123.65
FAR CHECK	
Perm. FAR Area (1.50)	667.57
Residential FAR	667.57
Proposed FAR Area	260.51
Total Proposed FAR Area	260.51
Consumed FAR (Factor)	0.59
Balance FAR Area	407.06
BUILT UP AREA CHECK	
Total Proposed BuiltUp Area	260.50
ARCHITECT (Regd)	RAJESH KUMAR
ENGINEER (Regd)	
SUPERVISOR (Regd)	
OWNER (Regd)	MERKHA PUNP TIGGA
DEVELOPMENT AUTHORITY	LOCAL BODY

COLOR INDEX	
PLOT BOUNDARY	Black
ABUTTING ROAD	Green
PROPOSED CONSTRUCTION	Red
COMMON PLOT	Yellow
ROAD WIDENING AREA	Orange
EXISTING (To be retained)	Blue
EXISTING (To be demolished)	Light Blue

Buildingwise Floor FAR Details

Floor Name	Building Name A (BUILDING)		Total	
	Proposed Built Up Area (Sq.mt.)	Proposed FAR Area (Sq.mt.)	Total Proposed Built Up Area (Sq.mt.)	Total FAR Area (Sq.mt.)
Ground Floor	130.25	130.25	130.25	130.25
First Floor	130.25	130.25	130.25	130.25
Terrace Floor	0.00	0.00	0.00	0.00
Total :	260.50	260.50	260.50	260.50

Building USE/SUBUSE Details

Building Name	Building Use	Building SubUse	Building Structure
A (BUILDING)	Residential	Residential Bldg/Apartment	Non-Highrise

LTP NAME AND SIGNATURE RAJESH KUMAR SINPC/DFTM/0006/2017	STRUCTURAL ENG'S NAME AND SIGNATURE	BUILDER NAME AND SIGNATURE
--	-------------------------------------	----------------------------

Proposal Basic Information

Proposal File No.	SINPC/BP/0065/W16/2018
Owner Name	MERKHA PUNP TIGGA
Khata No	75
Plot No	758
Village Name	Simdega
Use	Residential
SubUse	Residential Bldg/Apartment

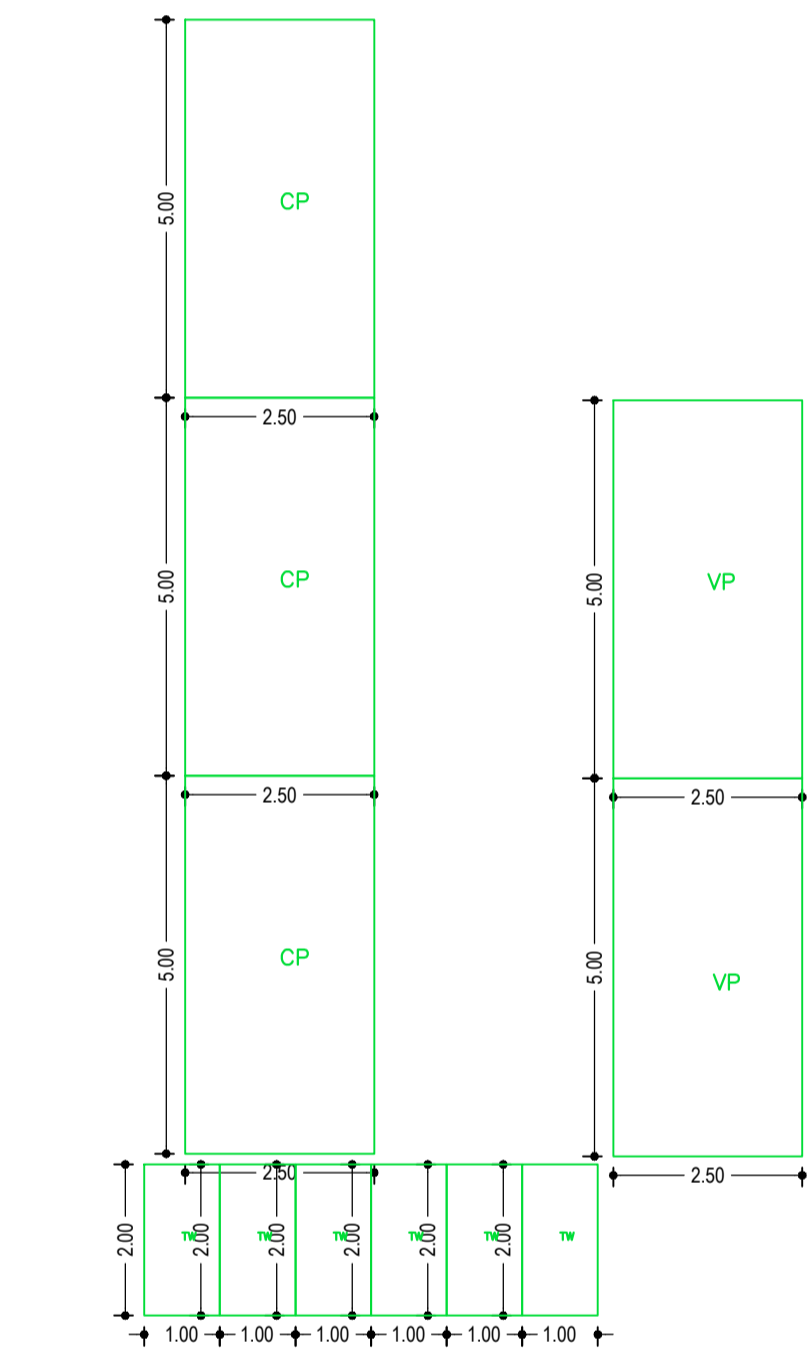
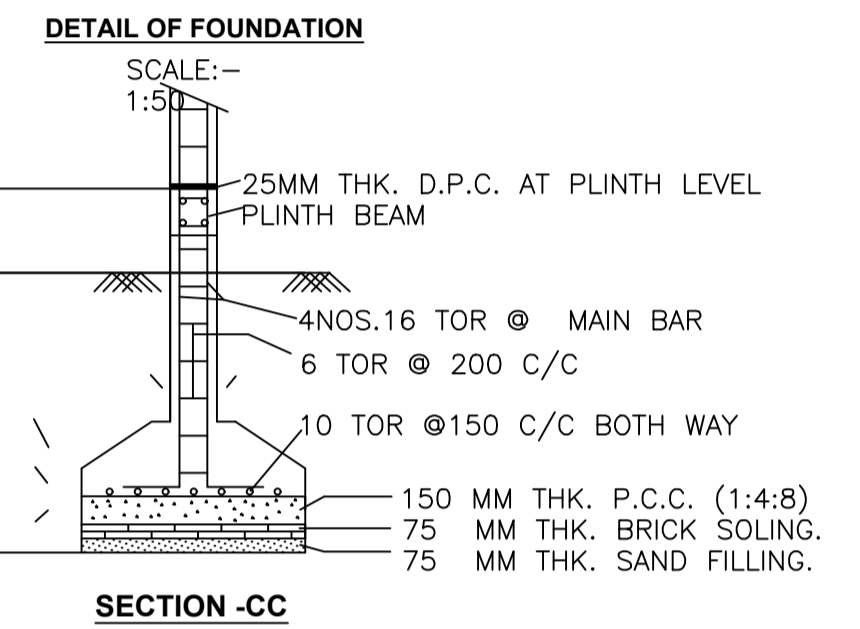
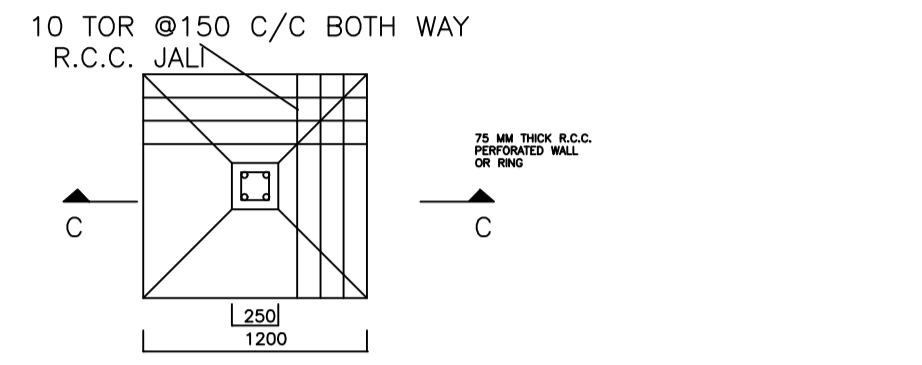
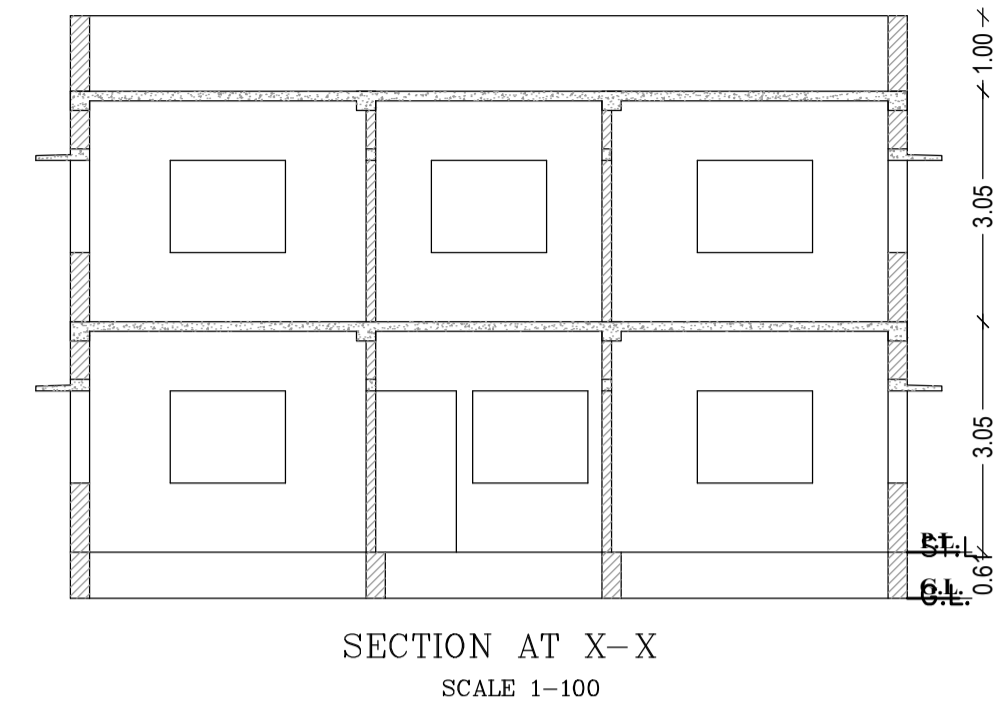
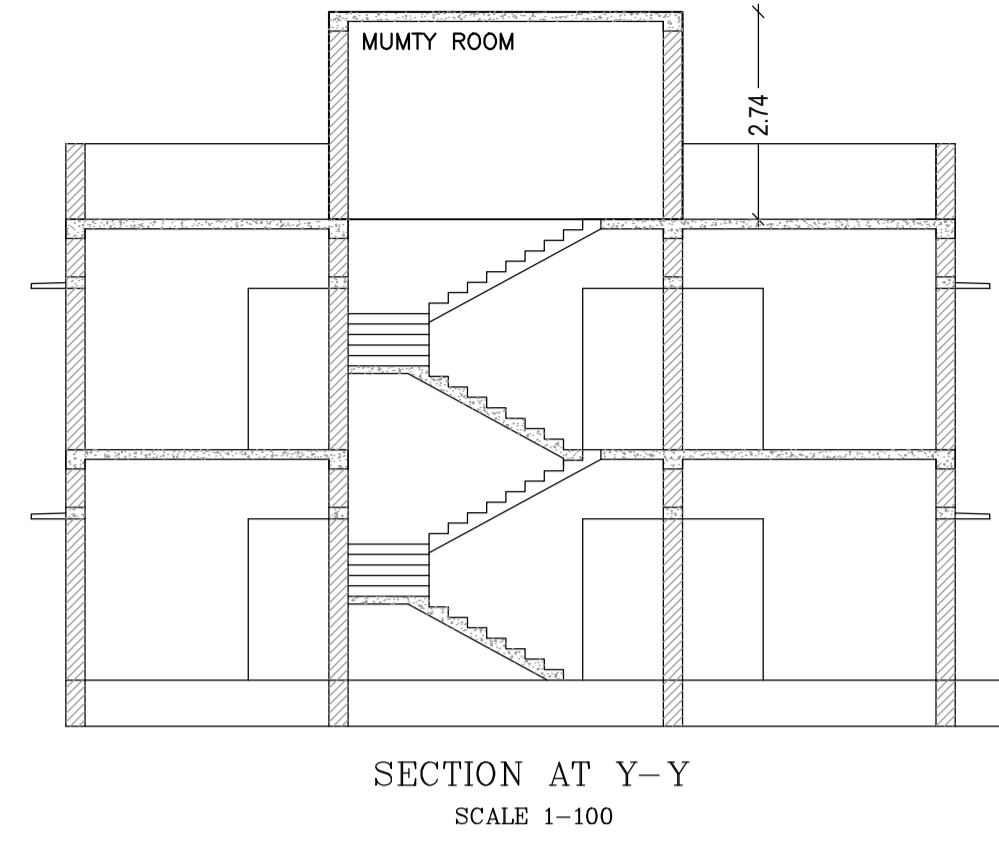
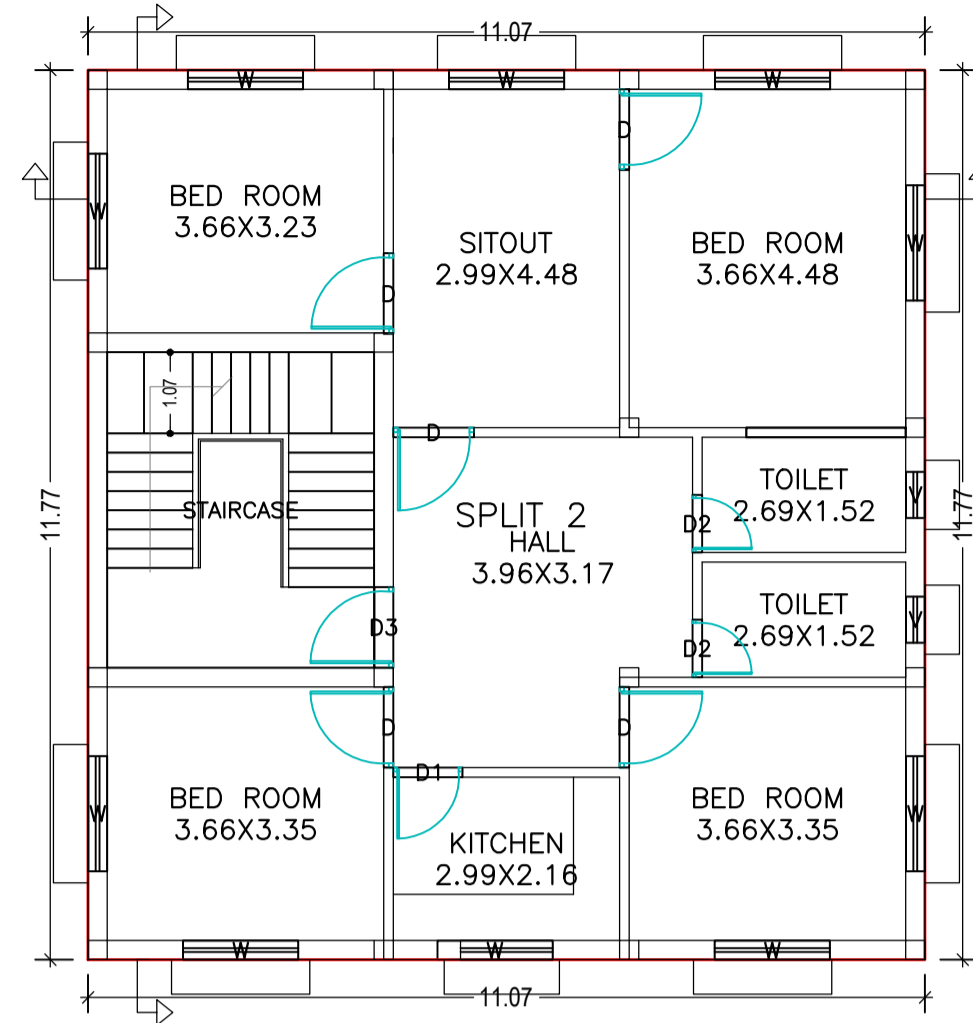
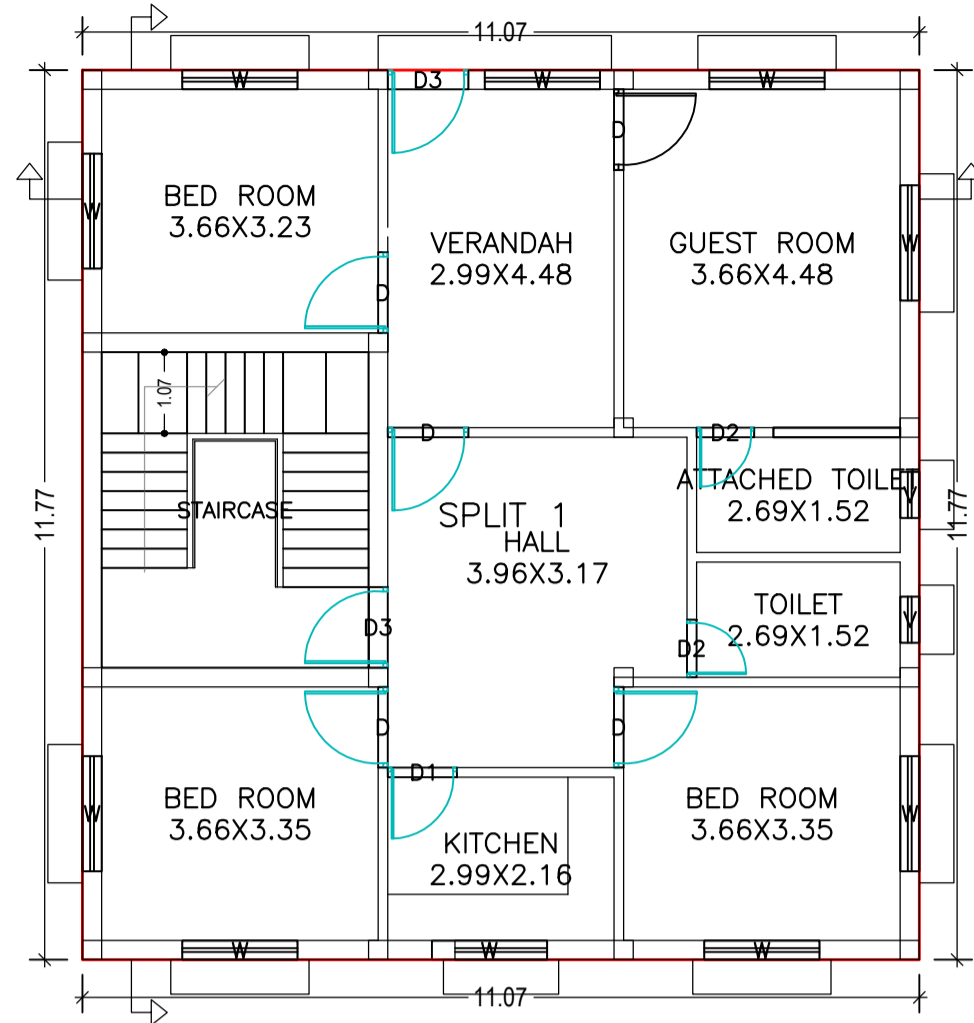

FIRST FLOOR PLAN (Proposed) SCALE 1:100

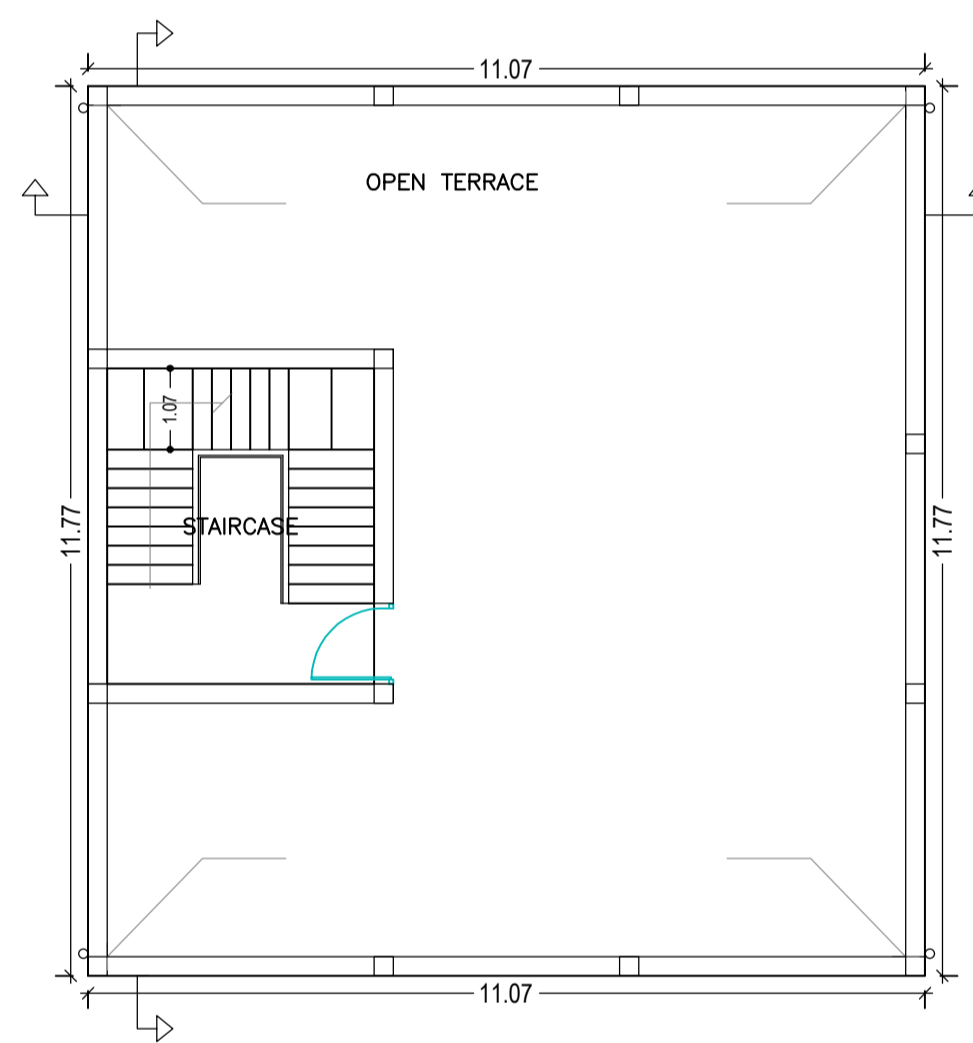

TERRACE FLOOR PLAN (Proposed) SCALE 1:100

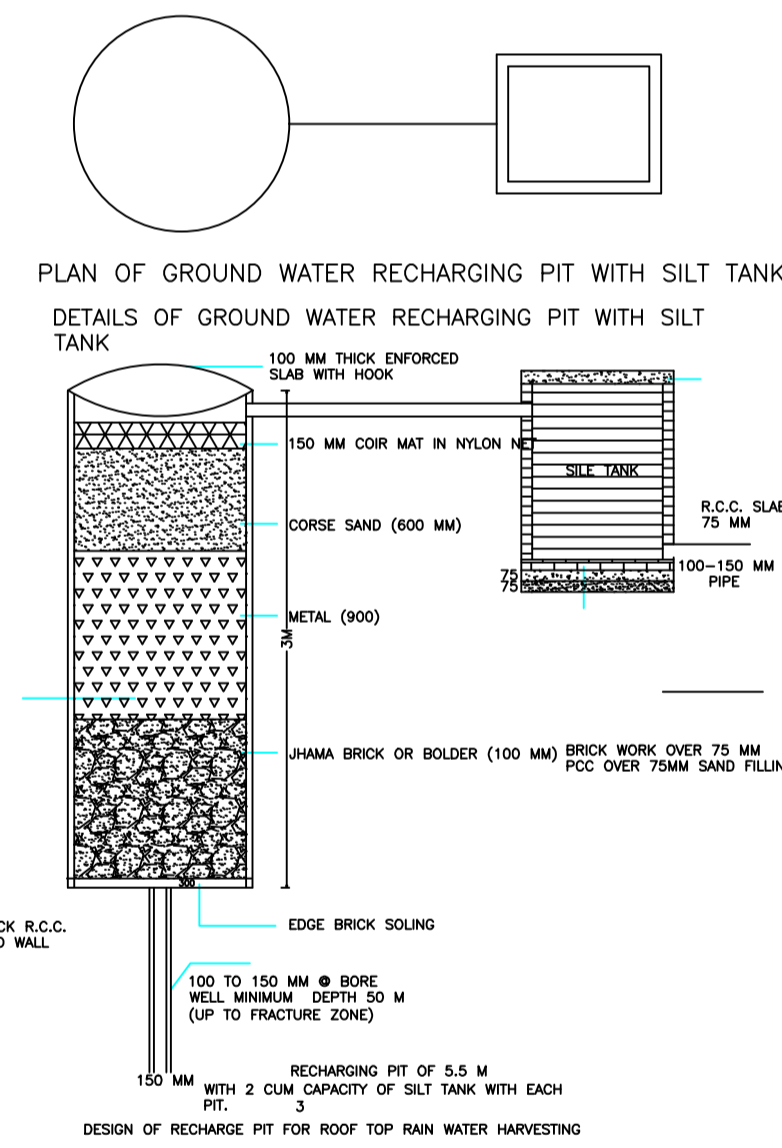

DESIGN OF RECHARGE PIT FOR ROOF TOP RAIN WATER HARVESTING

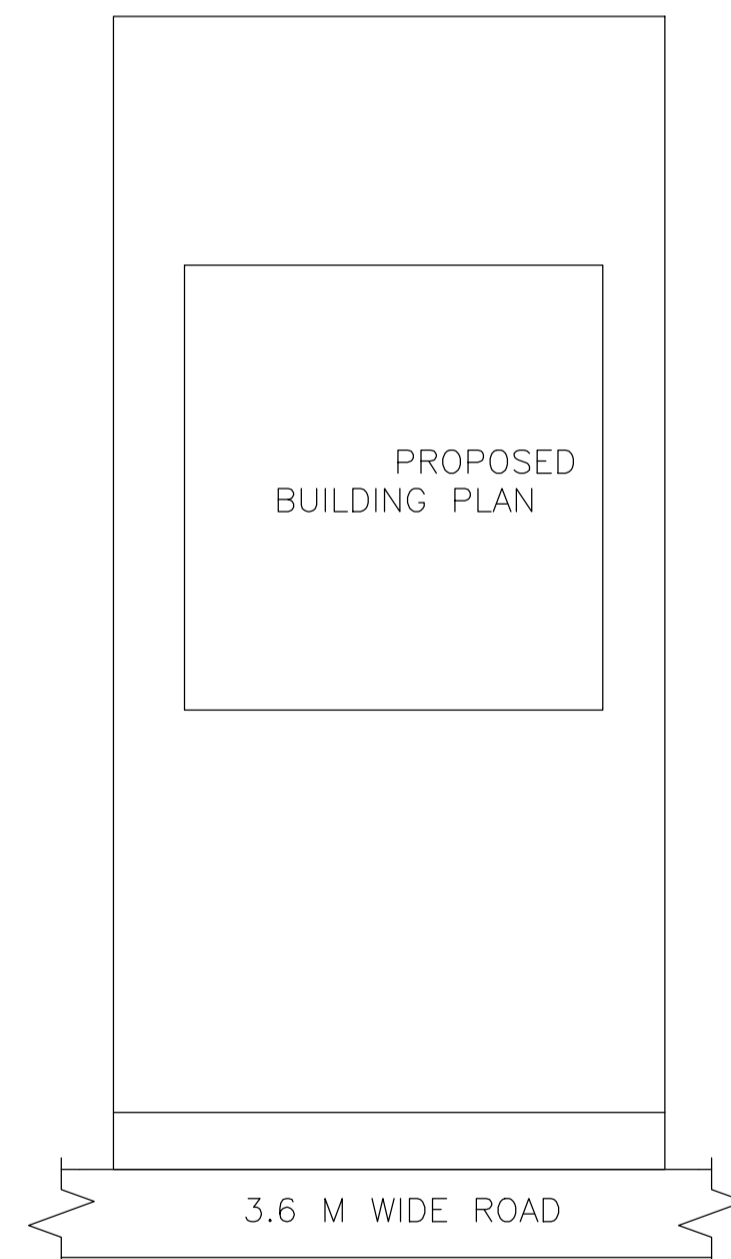

SITE PLAN SCALE 1-200

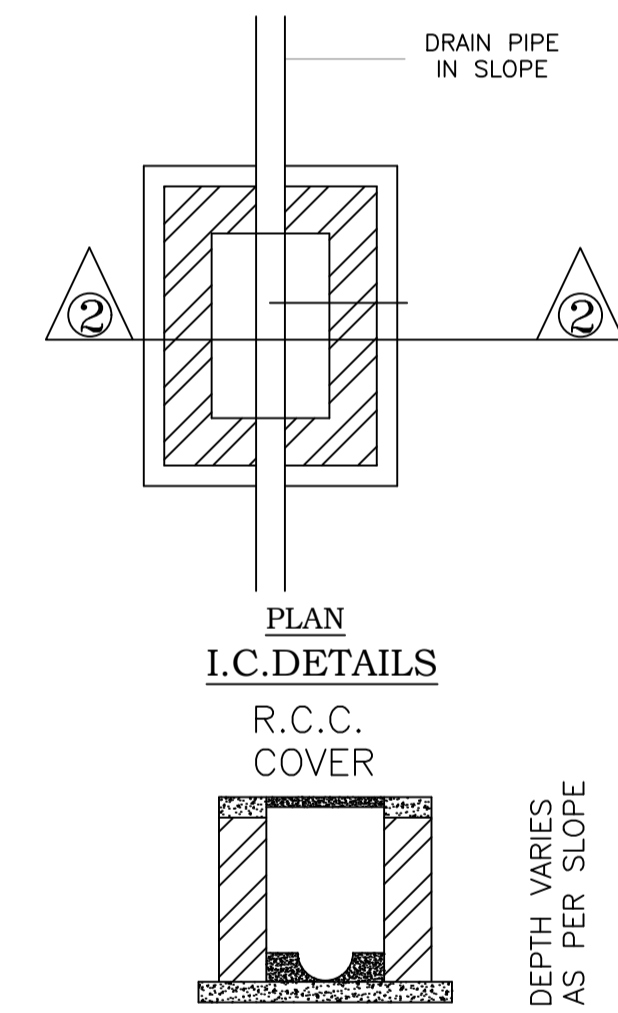

SECTION AT 2-2

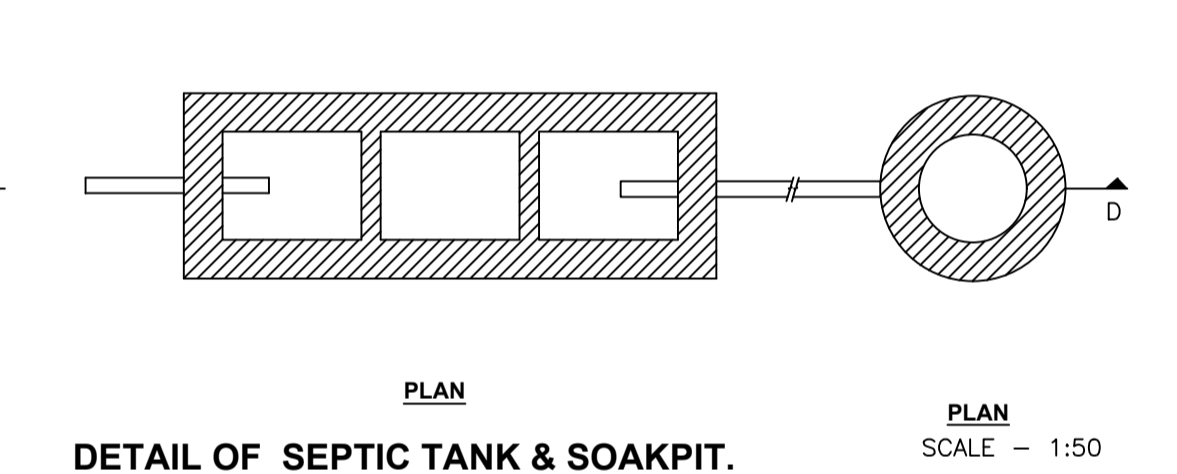

DETAIL OF SEPTIC TANK & SOAKPIT. SCALE - 1:50

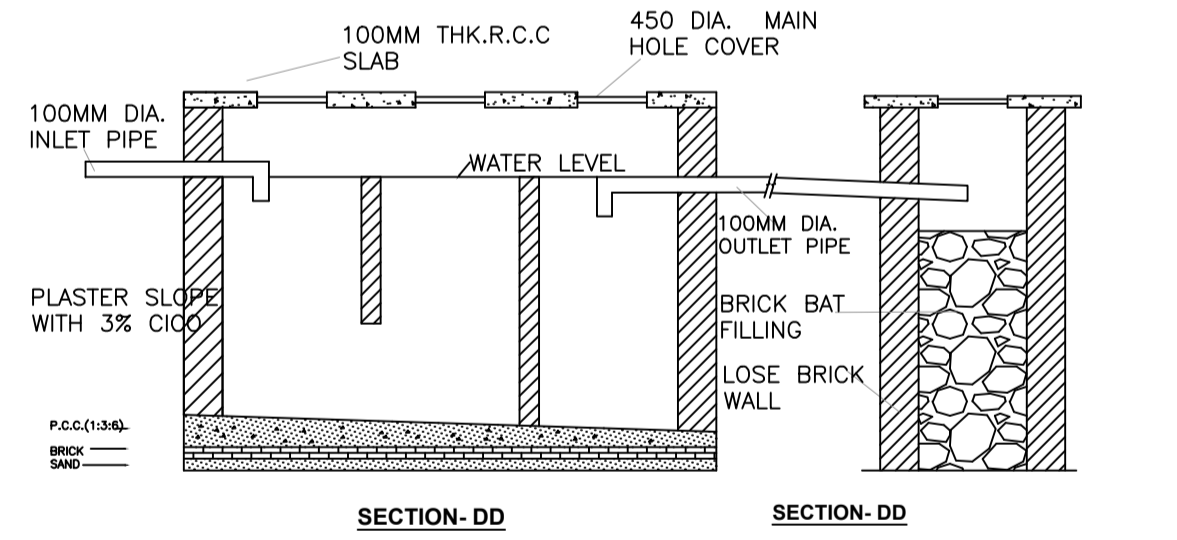

SECTION-DD SECTION-DD

GROUND FLOOR PLAN (Proposed) SCALE 1:100

Building :A (BUILDING)

Floor Name	Total Built Up Area (Sq.mt.)	Proposed FAR Area (Sq.mt.) Resi.	Total FAR Area (Sq.mt.)	Total Consumed Additional FAR Area (Sq.mt.)	Tnmt (No.)
Ground Floor	130.25	130.25	130.25	130.25	01
First Floor	130.25	130.25	130.25	130.25	01
Terrace Floor	0.00	0.00	0.00	0.00	00
Total:	260.50	260.50	260.50	260.50	02
Total Number of Same Buildings	1				
Total:	260.50	260.50	260.50	260.50	02

SCHEDULE OF DOOR:

BUILDING NAME	NAME	LENGTH	HEIGHT	NOS
A (BUILDING)	D2	0.76	2.10	04
A (BUILDING)	D1	0.91	2.10	02
A (BUILDING)	D	1.07	2.10	10
A (BUILDING)	D3	1.07	2.10	03

SCHEDULE OF WINDOW/VENTILATION:

BUILDING NAME	NAME	LENGTH	HEIGHT	NOS
A (BUILDING)	V	0.61	1.20	04
A (BUILDING)	W	1.52	1.20	20

UnitBUA Table for Building :A (BUILDING)

FLOOR	Name	UnitBUA Type	UnitBUA Area	Carpet Area	No. of Rooms	No. of Tenement
GROUND FLOOR PLAN	SPLIT 1	FLAT	101.20	100.99	9	1
FIRST FLOOR PLAN	SPLIT 2	FLAT	101.20	100.93	9	1
Total:	-	-	202.40	201.92	18	2

LTP NAME AND SIGNATURE RAJESH KUMAR SINPC/DFTMN/0006/2017	STRUCTURAL ENG'S NAME AND SIGNATURE	BUILDER NAME AND SIGNATURE
---	-------------------------------------	----------------------------

Proposal Basic Information	
Proposal File No.	SINPCBP/0065/W16/2018
Owner Name	MERKHA PUNP TIGGA
Khata No	75
Plot No	758
Village Name	Simdega
Use	Residential
SubUse	Residential Bldg/Apartment

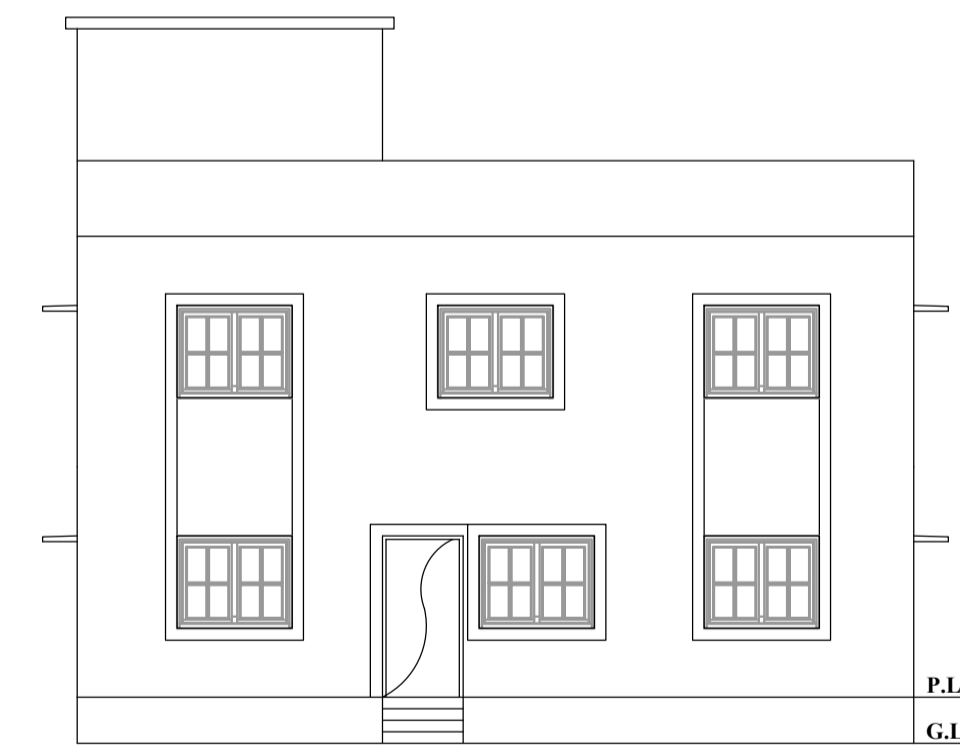
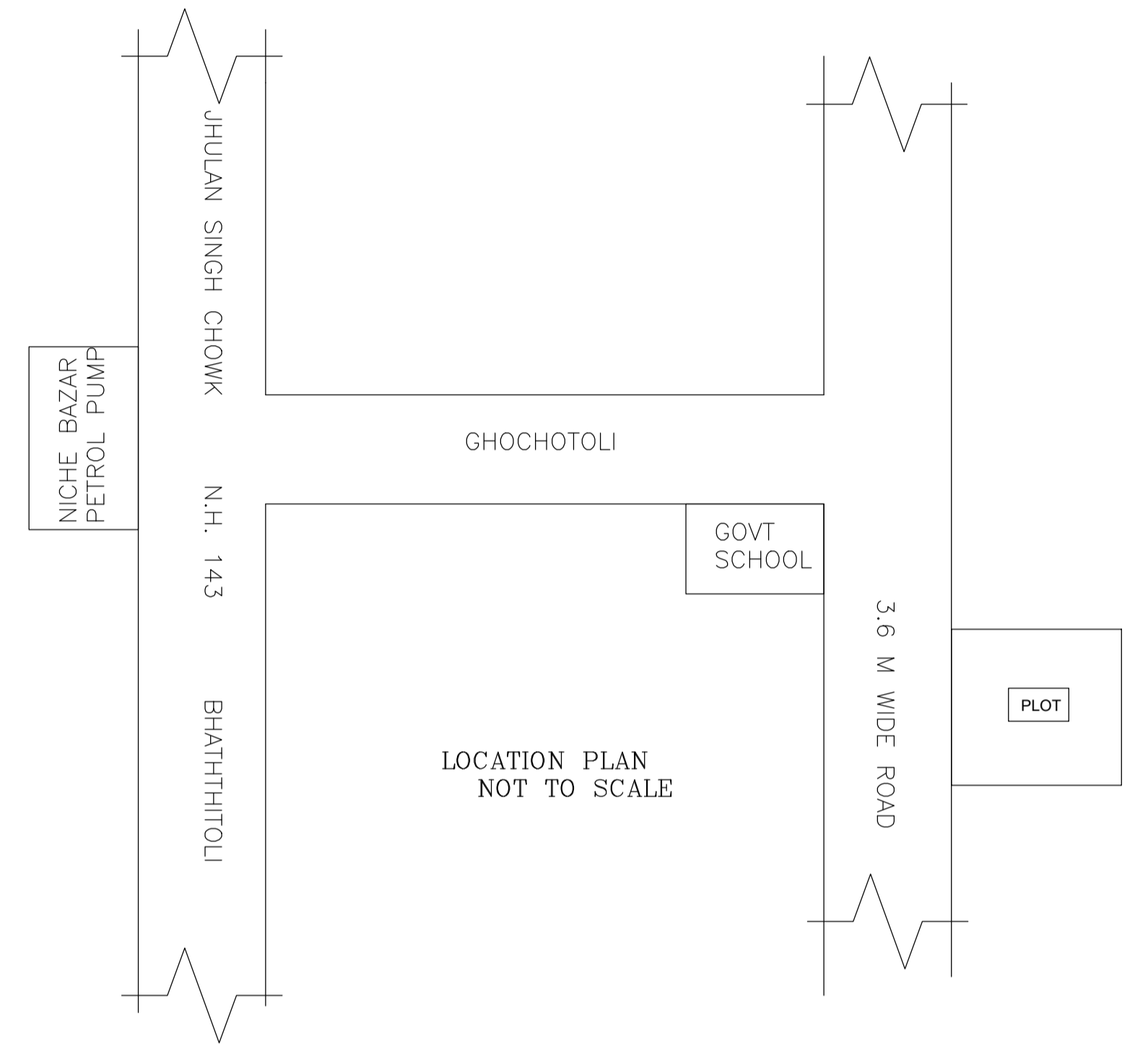

FRONT ELEVATION
SCALE 1-100

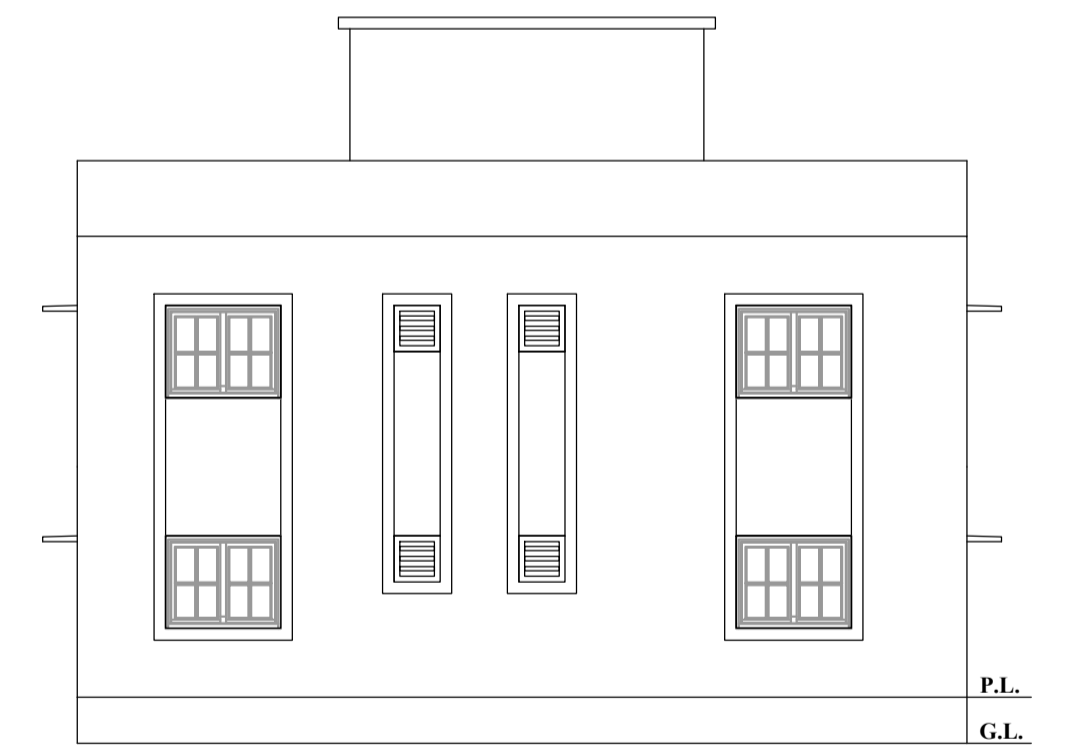

LEFT SIDE ELEVATION
SCALE 1-100

LTP NAME AND SIGNATURE	STRUCTURAL ENG'S NAME AND SIGNATURE	BUILDER NAME AND SIGNATURE
RAJESH KUMAR SINPC/DFTMN/0008/2017		