

SITE PLAN

SCALE 1:100

FAR & Tenement Details (Table 4c-1)

Building	No. of Same Bldg	Total Built Up Area (Sq.mt.)	Deductions (Area in Sq.mt.)		Proposed FAR Area (Sq.mt.)	Total FAR Area (Sq.mt.)	Total Consumed Additional FAR Area (Sq.mt.)	Trnmt (No.)
			Void	Resi.				
A1 (BUILDING)	1	195.68	6.90	188.78	188.78	188.78	02	
Grand Total :	1	195.68	6.90	188.78	188.78	188.78	02	

Proposal Basic Information

Proposal File No.	SINPC/BP/0035/W17/2018
Owner Name	DULAR KERKETTA
Khata No	41
Plot No	1937
Village Name	Simdega
Use	Residential
SubUse	Residential Bldg/Apartment

Required Parking (Table 7a)

Building Name	Type	SubUse	Area (Sq.mt.)	Units		Car		Visitors Car		TwoWheeler	
				Regd.	Prop.	Regd./Unit	Prop.	Regd./Unit	Prop.	Regd./Unit	Prop.
A1 (BUILDING)	Residential	Residential Bldg/Apartment	> 0	1	2.00	1	2	-	-	-	-
			> 0	1	2.00	-	-	-	-	1	2
			> 0	1	2.00	-	-	1	1	-	-
Total :			-	-	-	2	3	-	1	2	6

Parking Check (Table 7b)

Vehicle Type	Reqd.		Prop.	
	No.	Area	No.	Area
Car	-	-	3	37.50
Total Car	2	25.00	3	37.50
Visitor's Car Parking	1	12.50	2	25.00
TwoWheeler	2	4.00	6	12.00
Other Parking	-	-	-	225.97
Total		41.50		300.47

AREA STATEMENT SIMDEGA NAGAR PANCHAYAT	VERSION NO: 1.0.27
PROJECT DETAIL:	VERSION DATE: 18/05/2018
Region: JHARKHAND URBAN LOCAL BODIES	Plot Use: Residential
District: SIMDEGA	Plot SubUse: Residential Bldg/Apartment
Authority: SIMDEGA NAGAR PANCHAYAT	PlotNearby/ReligiousStructure: NA
Inward No: SINPC/BP/0035/W17/2018	Plot/SubPlot No: 1937
Application Type: General Proposal	North: -
Project Type: Building Permission	South: -
Nature of Development: New	East: -
Location of Development Area: New Area	West: -
AREA DETAILS:	SQ.MT.
AREA OF PLOT (Minimum)	(A) 606.92
Deduction for NetPlot Area	
Road Widening Area	42.56
Total	42.56
NET AREA OF PLOT(Gross Plot Area - Deduction from Gross Plot area)	(A-Deductions) 564.36
Deduction for Balance Plot Area(from Gross Plot Area)	
Road Widening Area	42.56
Common Plot	107.80
Total	150.35
BALANCE AREA OF PLOT(Net Plot Area - Recreational/Amenity space)	(A-Deductions) 456.56
PLOT AREA FOR COVERAGE(Net Plot Area)	(A-Deductions) 564.36
Plot Area for FAR (Net Plot Area + Road Widening Area)	(A-Deductions) 564.36
COVERAGE CHECK	
Permissible Coverage area (60.00 %)	338.62
Proposed Coverage Area (17.34 %)	97.84
Total Prop. Coverage Area (17.34 %)	97.84
Balance coverage area (42.66 %)	240.78
FAR CHECK	
Perm. FAR Area (1.50)	846.54
Total Perm. FAR area	846.54
Residential FAR	188.79
Proposed FAR Area	188.79
Total Proposed FAR Area	188.79
Consumed FAR (Factor)	0.33
Balance FAR Area	657.75
BUILT UP AREA CHECK	
Total Proposed BuiltUp Area	195.68
ARCHITECT (Regd)	RAJESH KUMAR
ENGINEER (Regd)	
SUPERVISOR (Regd)	
OWNER (Regd)	DULAR KERKETTA
DEVELOPMENT AUTHORITY	LOCAL BODY

COLOR INDEX	
PLOT BOUNDARY	Black
ABUTTING ROAD	Green
PROPOSED CONSTRUCTION	Red
COMMON PLOT	Yellow
ROAD WIDENING AREA	Light Blue
EXISTING (To be retained)	Blue
EXISTING (To be demolished)	Orange

Buildingwise Floor FAR Details

Floor Name	Building Name A1 (BUILDING)		Total	
	Proposed Built Up Area (Sq.mt.)	Proposed FAR Area (Sq.mt.)	Total Proposed Built Up Area (Sq.mt.)	Total FAR Area (Sq.mt.)
Ground Floor	97.84	94.39	97.84	94.39
First Floor	97.84	94.39	97.84	94.39
Terrace Floor	0.00	0.00	0.00	0.00
Total :	195.68	188.78	195.68	188.78

Building USE/SUBUSE Details

Building Name	Building Use	Building Structure
A1 (BUILDING)	Residential Bldg/Apartment	Non-Highrise

LTP NAME AND SIGNATURE	STRUCTURAL ENG'S NAME AND SIGNATURE	BUILDER NAME AND SIGNATURE
RAJESH KUMAR SINPC/DFTMN/0008/2017		

Proposal Basic Information

Proposal File No.	SINPC/BP/0035/W17/2018
Owner Name	DULAR KERKETTA
Khata No	41
Plot No	1937
Village Name	Simdega
Use	Residential
SubUse	Residential Bldg/Apartment

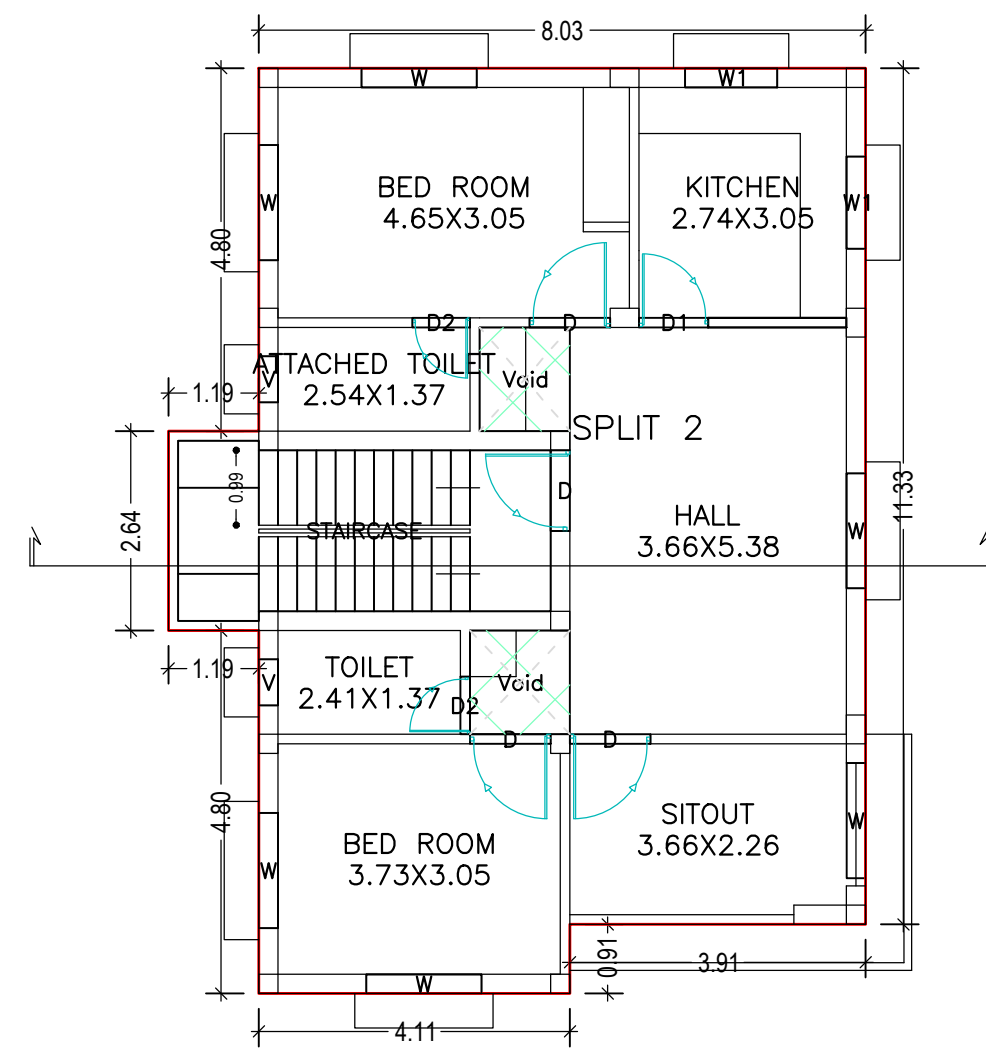
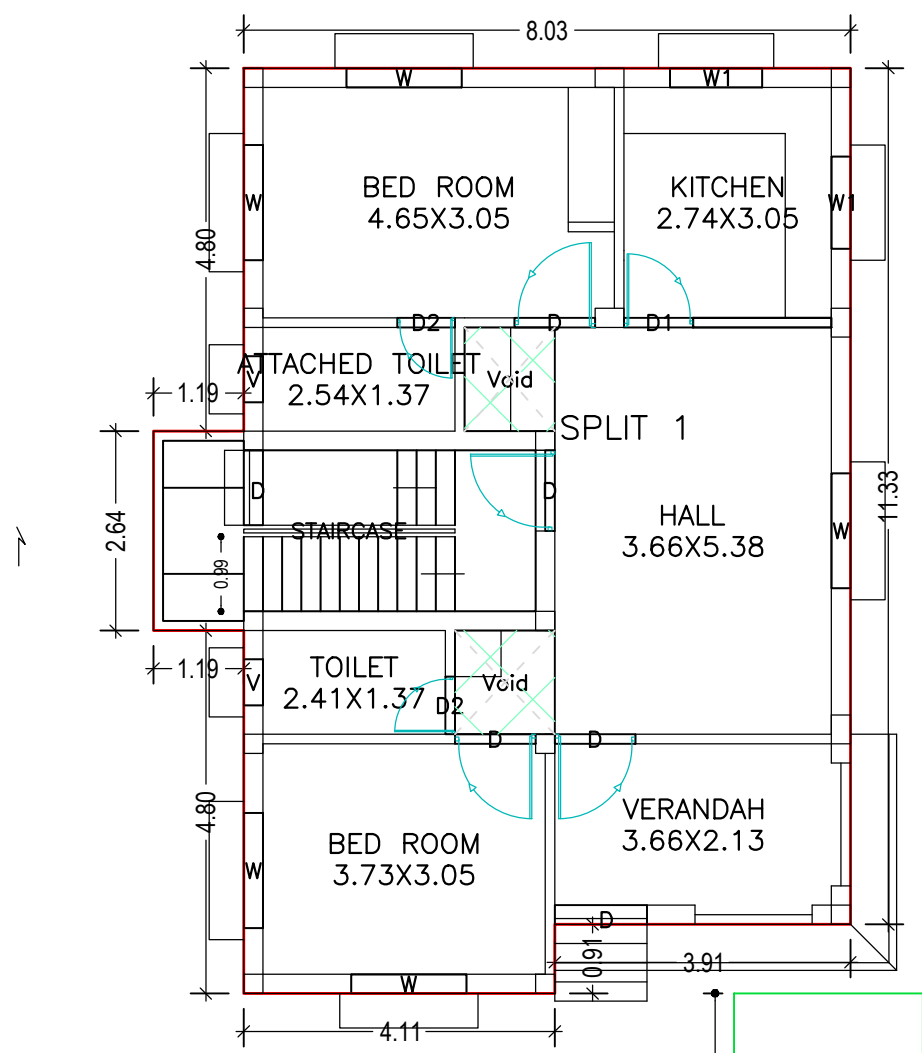

FIRST FLOOR PLAN
(Proposed)
(SCALE 1:100)

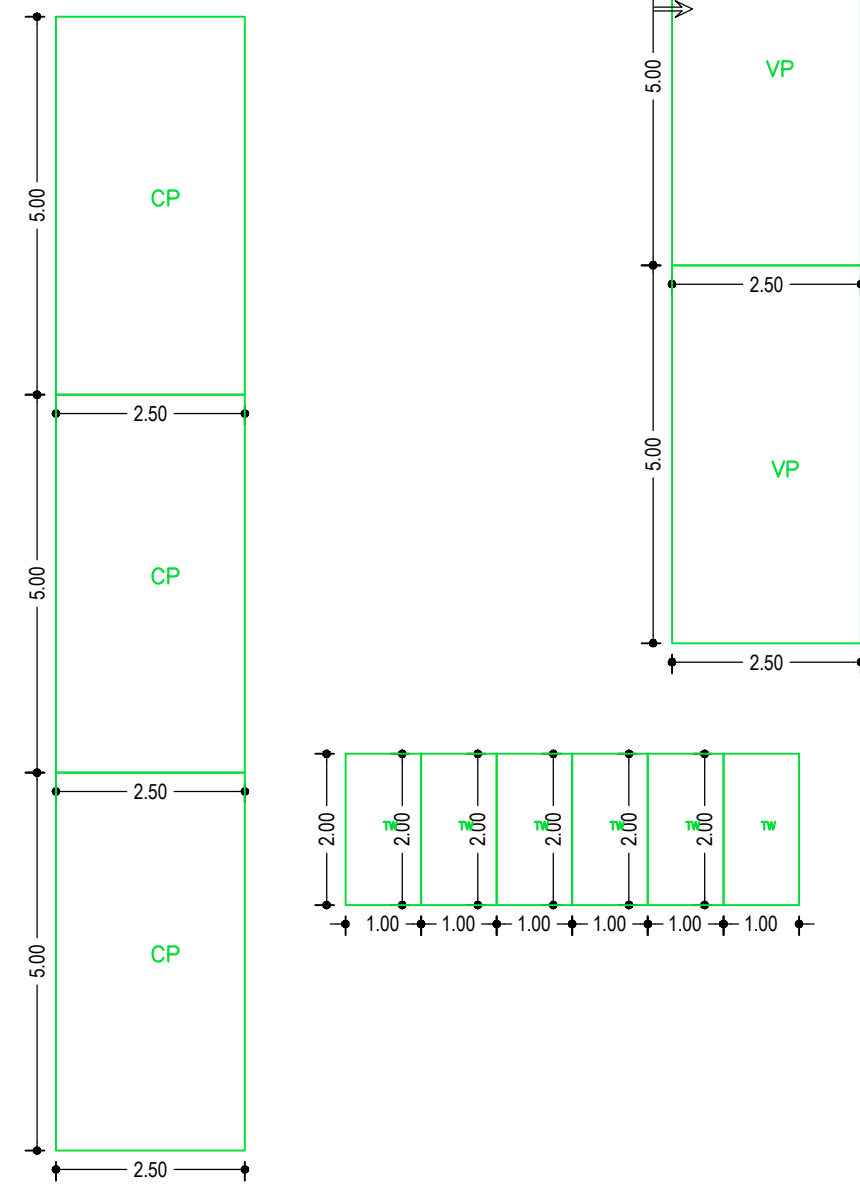

GROUND FLOOR PLAN
(Proposed)
(SCALE 1:100)

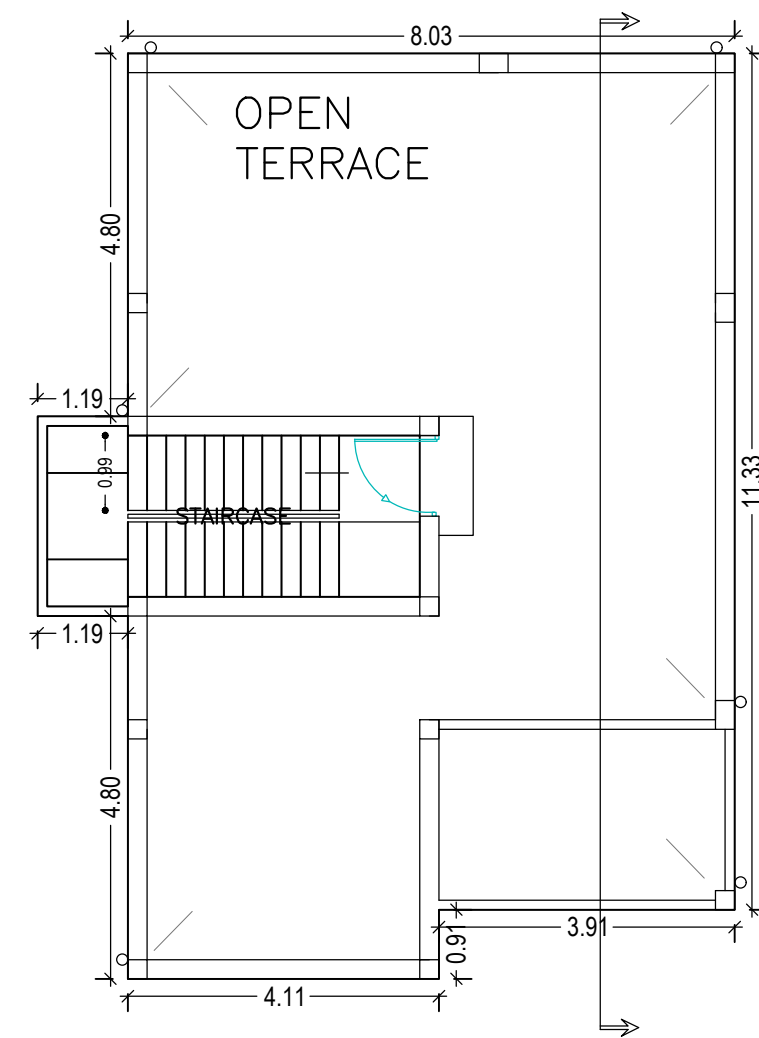

TERRACE FLOOR PLAN
(SCALE 1:100)

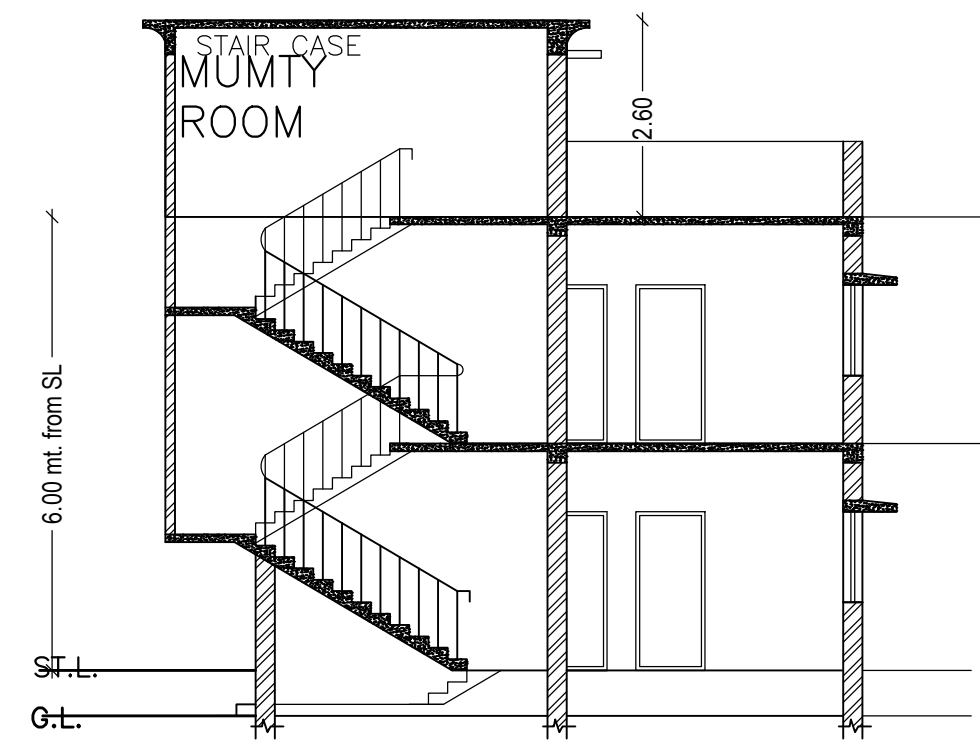

SECTION ON
SCALE 1:100

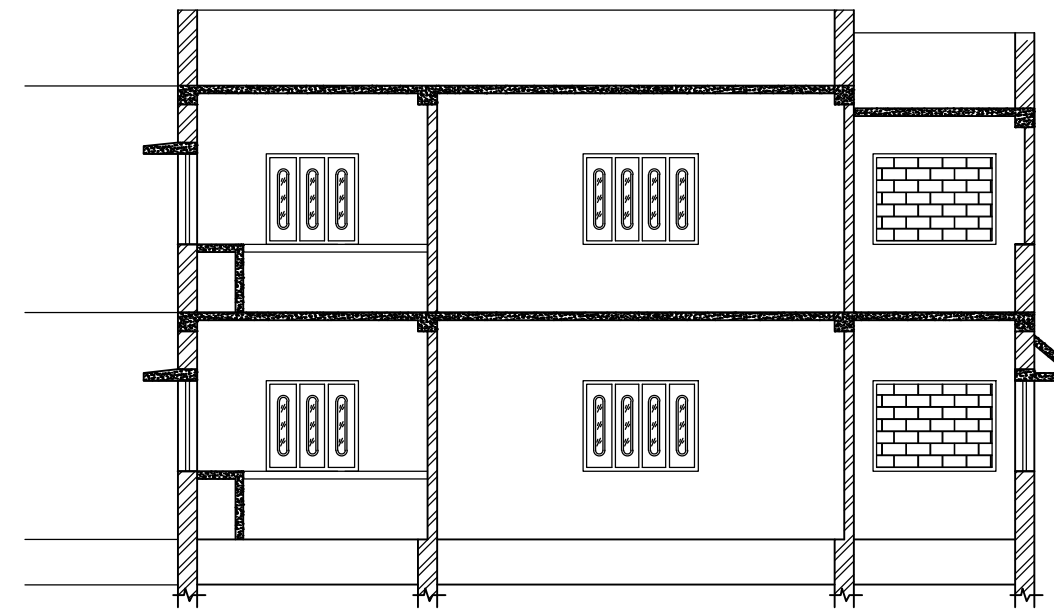

SECTION ON
SCALE 1:100

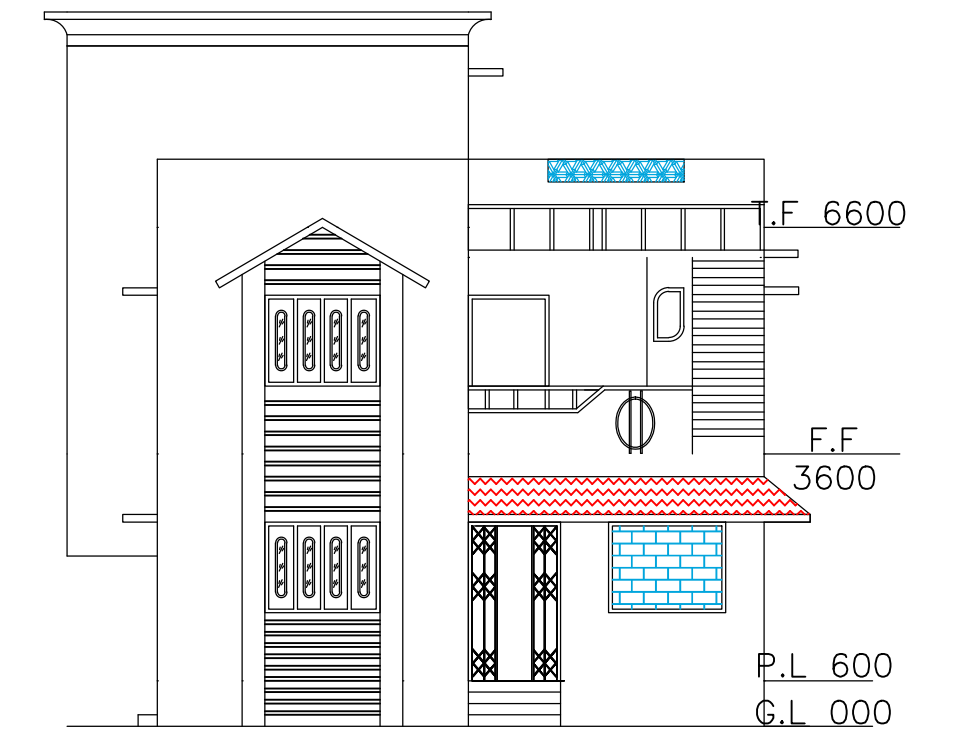

FRONT ELEVATION
SCALE 1:100

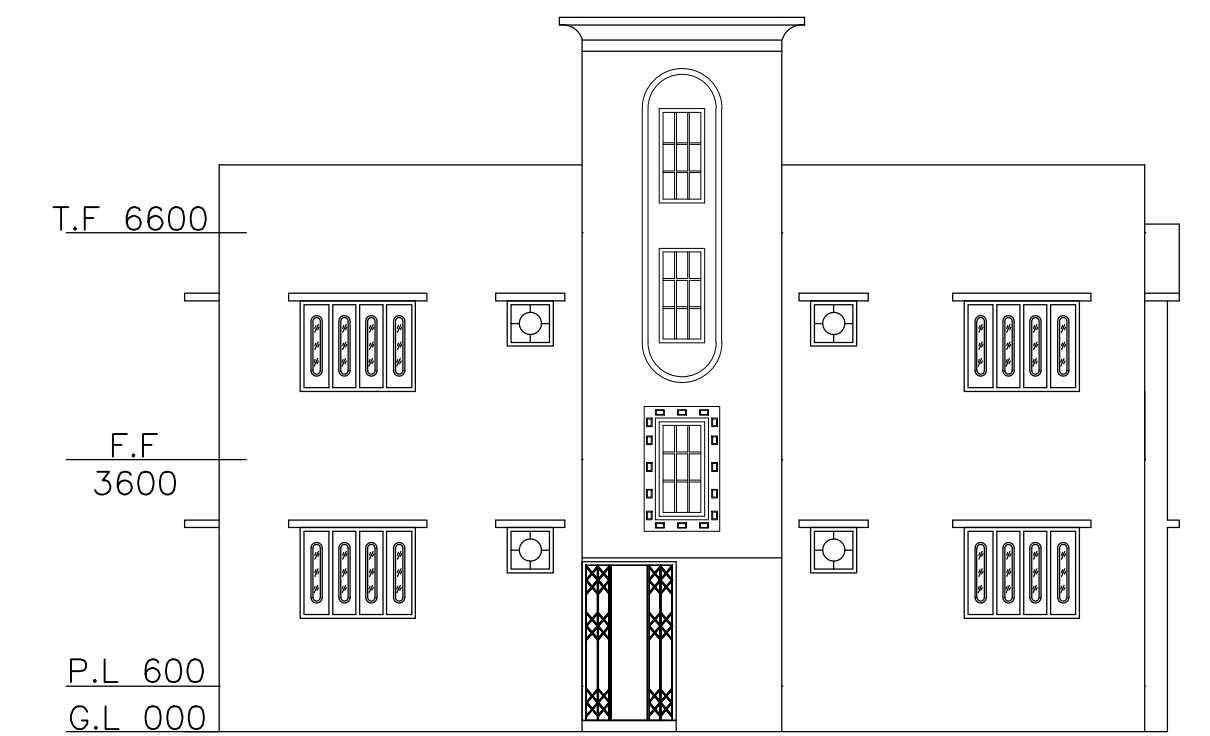

LEFT SIDE ELEVATION
SCALE 1:100

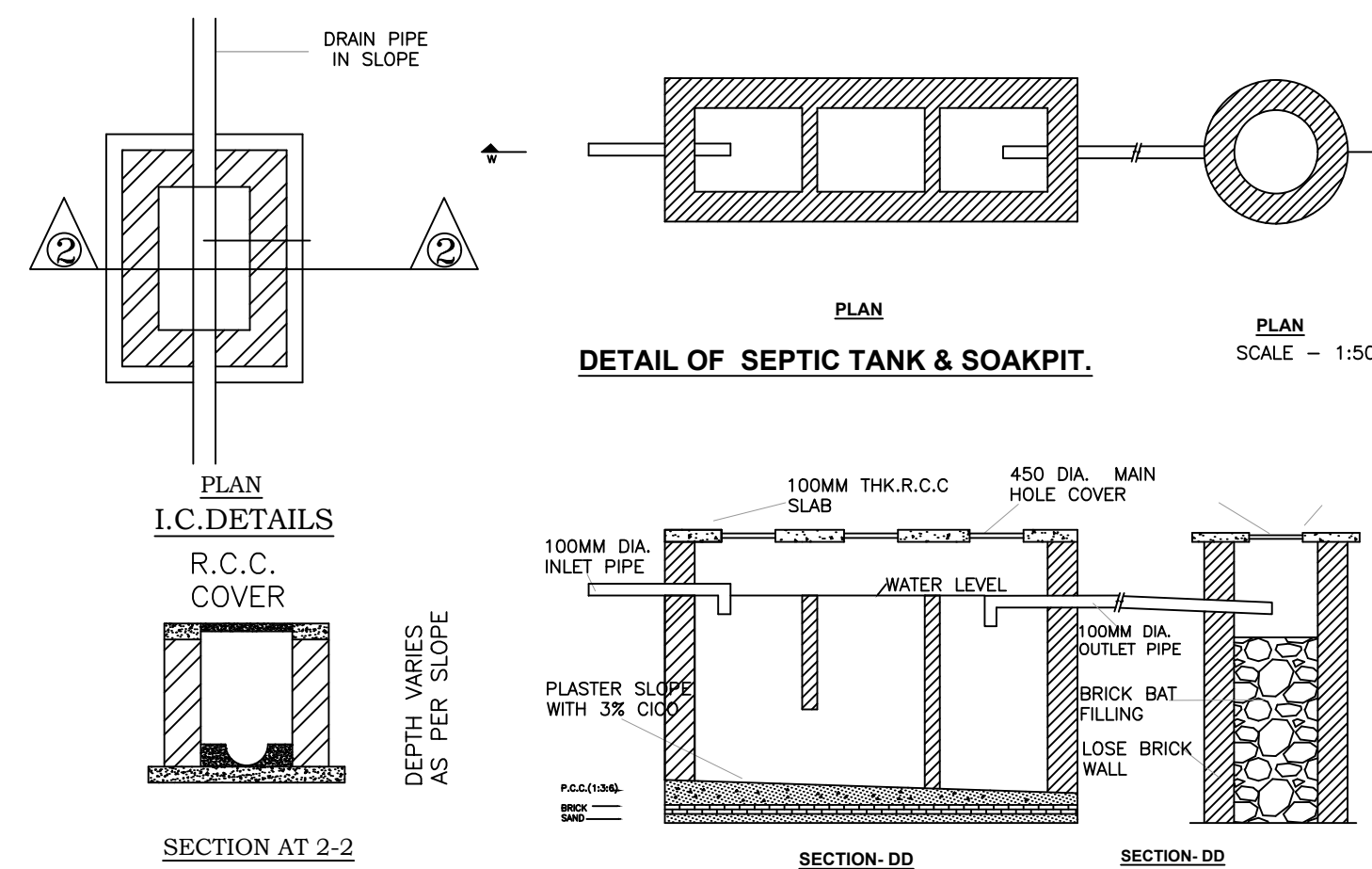

DETAIL OF SEPTIC TANK & SOAKPIT.
SCALE - 1:50

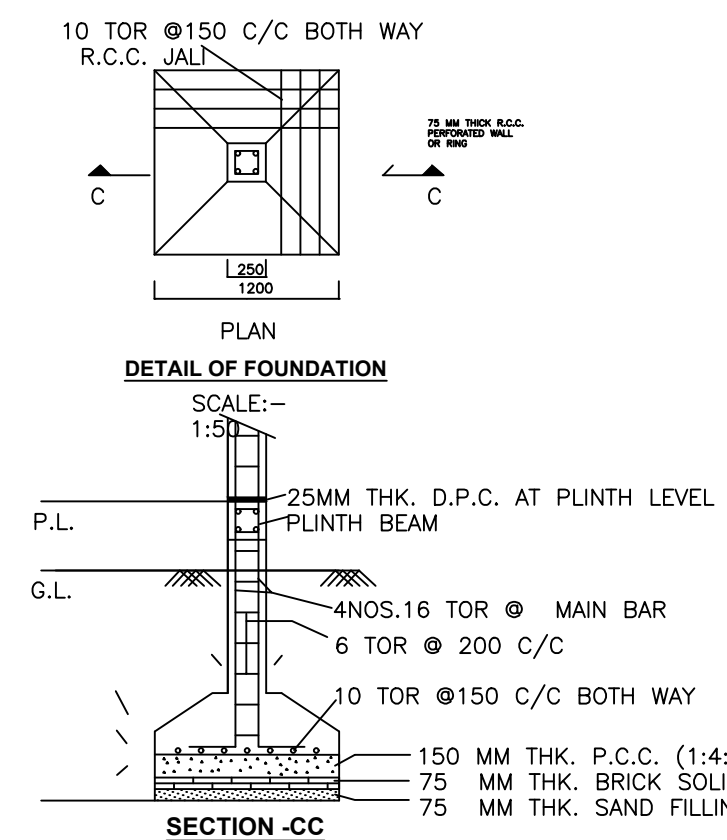

DETAIL OF FOUNDATION
SCALE:- 1:50

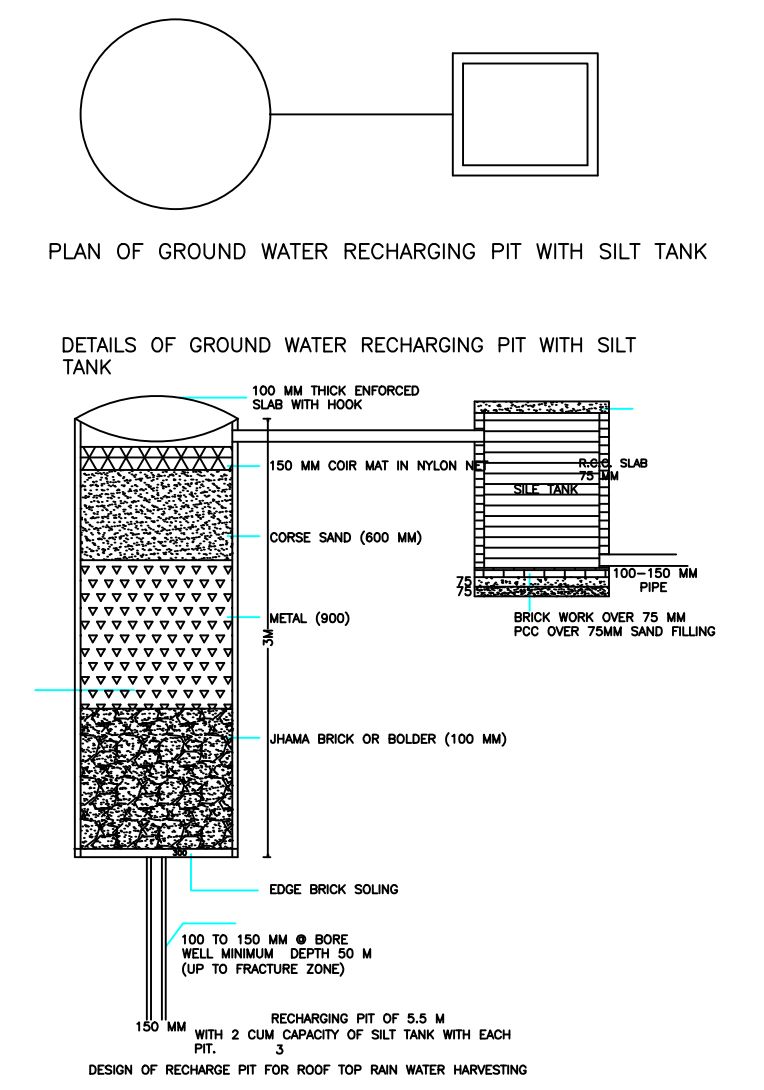

PLAN OF GROUND WATER RECHARGING PIT WITH SILT TANK

DETAILS OF GROUND WATER RECHARGING PIT WITH SILT TANK

Building :A1 (BUILDING)

Floor Name	Total Built Up Area (Sq.mt.)	Deductions (Area in Sq.mt.)	Proposed FAR Area (Sq.mt.)	Total FAR Area (Sq.mt.)	Total Consumed Additional FAR Area (Sq.mt.)	Trmt (No.)
Ground Floor	97.84	3.45	94.39	94.39	94.39	01
First Floor	97.84	3.45	94.39	94.39	94.39	01
Terrace Floor	0.00	0.00	0.00	0.00	0.00	00
Total :	195.68	6.90	188.78	188.78	188.78	02
Total Number of Same Buildings	1					
Total :	195.68	6.90	188.78	188.78	188.78	02

SCHEDULE OF DOOR:

BUILDING NAME	NAME	LENGTH	HEIGHT	NOS
A1 (BUILDING)	D2	0.76	2.10	04
A1 (BUILDING)	D1	0.91	2.10	02
A1 (BUILDING)	D	1.07	2.10	08
A1 (BUILDING)	D	1.22	2.10	01

SCHEDULE OF WINDOW/VENTILATION:

BUILDING NAME	NAME	LENGTH	HEIGHT	NOS
A1 (BUILDING)	V	0.61	1.20	04
A1 (BUILDING)	W1	1.22	1.20	04
A1 (BUILDING)	W	1.52	1.20	11

UnitBUA Table for Building :A1 (BUILDING)

FLOOR	Name	UnitBUA Type	UnitBUA Area	Carpet Area	No. of Rooms	No. of Tenement
GROUND FLOOR PLAN	SPLIT 1	FLAT	71.12	70.89	7	1
FIRST FLOOR PLAN	SPLIT 2	FLAT	71.60	71.37	7	1
Total:	-	-	142.72	142.26	14	2

LTP NAME AND SIGNATURE	STRUCTURAL ENG'S NAME AND SIGNATURE	BUILDER NAME AND SIGNATURE
RAJESH KUMAR SINPC/DFTMN/0006/2017		

Proposal Basic Information	
Proposal File No.	SINPC/BP/0035/W17/2018
Owner Name	DULAR KERKETTA
Khata No	41
Plot No	1937
Village Name	Simdega
Use	Residential
SubUse	Residential Bldg/Apartment

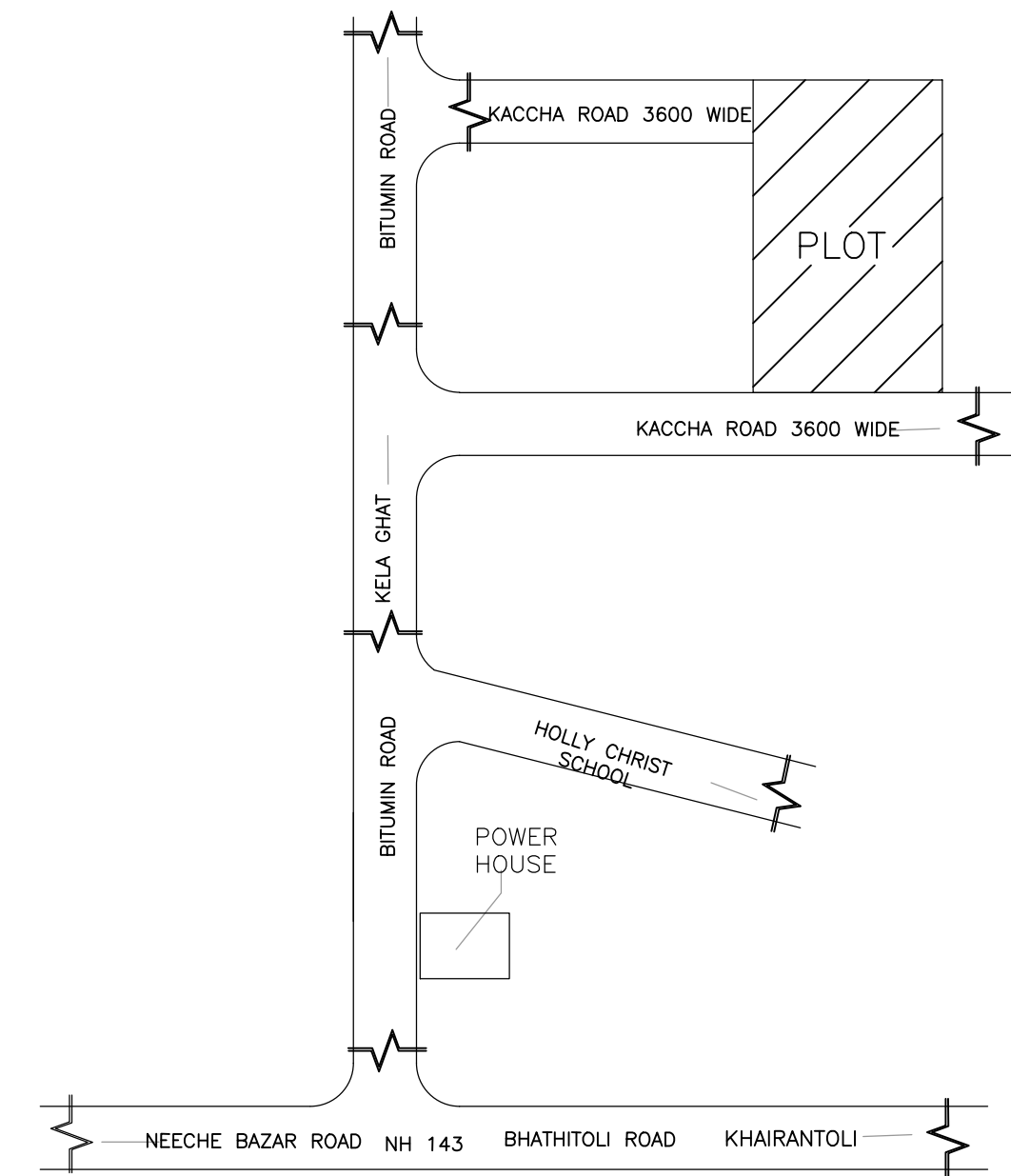

LOCATION PLAN 
NOT TO SCALE

LTP NAME AND SIGNATURE	STRUCTURAL ENG'S NAME AND SIGNATURE	BUILDER NAME AND SIGNATURE
RAJESH KUMAR SINPC/DFTMN/0008/2017		