

SITE PLAN

(Scale - 1:200)



FAR & Tenement Details (Table 4c-1)

Building	No. of Same Bldg	Total Built Up Area (Sq.mt.)	Proposed FAR Area (Sq.mt.) Resi.	Total Consumed Additional FAR Area (Sq.mt.)	Tnmt (No.)
A (SRI AMAR JYOTI KERKETTA)	1	163.08	163.08	163.08	01
Grand Total	1	163.08	163.08	163.08	01

Proposal Basic Information

Proposal File No.	SINPC/BP/0028/W17/2018
Owner Name	AMAR JYOTI KERKETTA
Khata No	41
Plot No	1937
Village Name	Simdega
Use	Residential
SubUse	Residential Bldg/Apartment

AREA STATEMENT SIMDEGA NAGAR PANCHAYAT		VERSION NO. : 1.0.29
PROJECT DETAIL		VERSION DATE: 30/06/2018
Region: JHARKHAND URBAN LOCAL BODIES	Plot Use: Residential	
District: SIMDEGA	Plot SubUse: Residential Bldg/Apartment	
Authority: SIMDEGA NAGAR PANCHAYAT	PlotNearbyReligiousStructure: NA	
Inward No: SINPC/BP/0028/W17/2018	PlotSubPlot No: 1937	
Application Type: General Proposal	North: -	
Project Type: Building Permission	South: -	
Nature of Development: New	East: -	
Location of Development Area: Old Area	West: -	
AREA DETAILS:		SQ.MT.
AREA OF PLOT (Minimum)	(A)	3061.76
Deduction for NetPlot Area		
Surrender Free of Cost		109.76
Total		109.76
NET AREA OF PLOT(Gross Plot Area - Deduction from Gross Plot area)	(A-Deductions)	2952.00
Deduction for Balance Plot Area(from Gross Plot Area)		
Surrender Free of Cost		109.76
Common Plot		893.86
Total		1003.62
BALANCE AREA OF PLOT(Net Plot Area - Recreational/Amenity space)	(A-Deductions)	2058.14
PLOT AREA FOR COVERAGE(Net Plot Area)	(A-Deductions)	2952.00
Plot Area for FAR (Net Plot Area + RoadWidening Area)	(A-Deductions)	3061.76
COVERAGE CHECK		
Permissible Coverage area (50.00 %)		1476.00
Proposed Coverage Area (5.52 %)		163.08
Total Prop. Coverage Area (5.52 %)		163.08
Balance coverage area (44.48 %)		1312.92
FAR CHECK		
Perm. FAR Area (1.50)		4592.64
Total Perm. FAR area		4592.64
Residential FAR		163.08
Proposed FAR Area		163.08
Total Proposed FAR Area		163.08
Consumed FAR (Factor)		0.05
Balance FAR Area		4429.56
BUILT UP AREA CHECK		
Total Proposed BuiltUp Area		163.08
ARCHITECT (Regd)		MD RAGIB SAYEED
ENGINEER (Regd)		
SUPERVISOR (Regd)		
OWNER (Regd)		AMAR JYOTI KERKETTA
DEVELOPMENT AUTHORITY		LOCAL BODY

COLOR INDEX	
PLOT BOUNDARY	Black
ABUTTING ROAD	Green
PROPOSED CONSTRUCTION	Red
COMMON PLOT	Yellow
ROAD WIDENING AREA	Orange
EXISTING (To be retained)	Blue
EXISTING (To be demolished)	Light Blue

Buildingwise Floor FAR Details

Floor Name	Building Name		Total	
	Proposed Built Up Area (Sq.mt.)	Proposed FAR Area (Sq.mt.)	Total Proposed Built Up Area (Sq.mt.)	Total FAR Area (Sq.mt.)
Ground Floor	163.08	163.08	163.08	163.08
Terrace Floor	0.00	0.00	0.00	0.00
Total	163.08	163.08	163.08	163.08

Building USE/SUBUSE Details

Building Name	Building Use	Building SubUse	Building Structure
A (SRI AMAR JYOTI KERKETTA)	Residential	Residential Bldg/Apartment	Non-Highrise

LTP NAME AND SIGNATURE	STRUCTURAL ENG'S NAME AND SIGNATURE	BUILDER NAME AND SIGNATURE
MD RAGIB SAYEED SINPC/ENG/0001/2017		

Proposal Basic Information	
Proposal File No.	SINPC/EP/0028/W17/2018
Owner Name	AMAR JYOTI KERKETTA
Khata No	41
Plot No	1937
Village Name	Simdega
Use	Residential
SubUse	Residential Bldg/Apartment

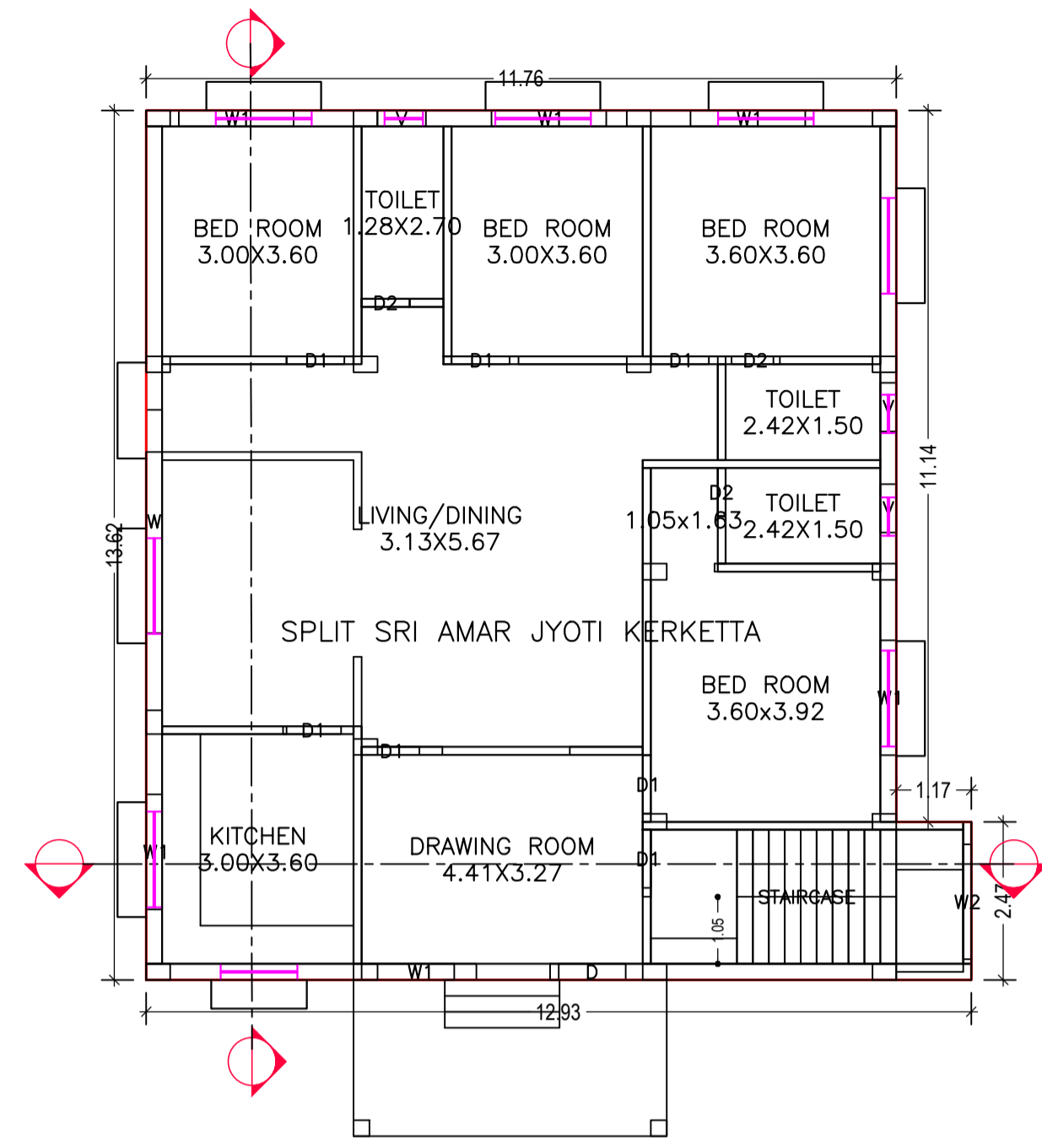

GROUND FLOOR PLAN (Proposed) (SCALE 1:100)

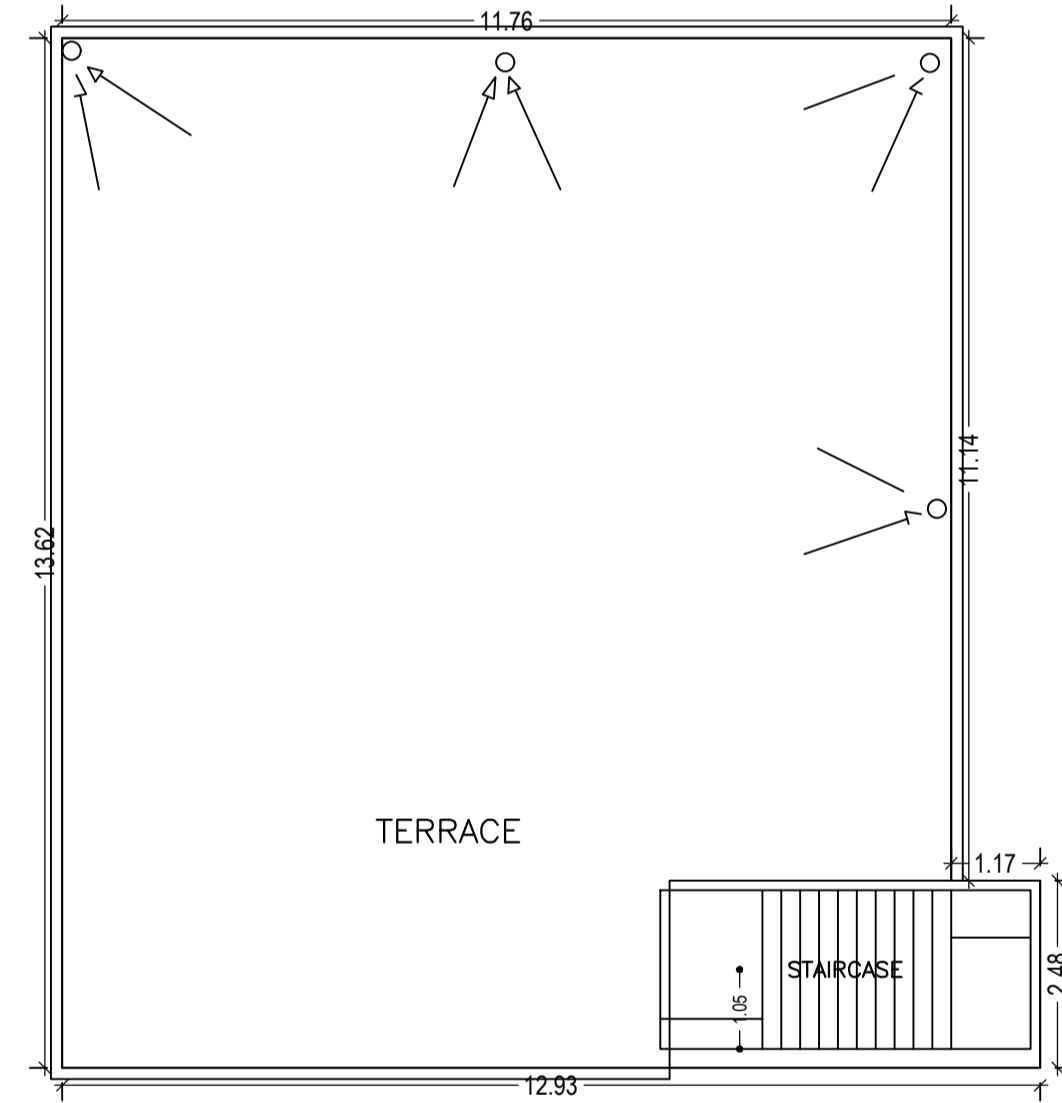

TERRACE FLOOR PLAN (SCALE 1:100)

Building :A (SRI AMAR JYOTI KERKETTA)

Floor Name	Total Built Up Area (Sq.mt.)	Proposed FAR Area (Sq.mt.)	Total FAR Area (Sq.mt.)	Total Consumed Additional FAR Area (Sq.mt.)	Tnmt (No.)
Terrace Floor	163.08	163.08	163.08	163.08	01
Total	0.00	0.00	0.00	0.00	00
Total Number of Same Buildings	163.08	163.08	163.08	163.08	01
Total	163.08	163.08	163.08	163.08	01

SCHEDULE OF DOOR:

	NAME	LENGTH	HEIGHT	NOS
A (SRI AMAR JYOTI KERKETTA)	D2	0.76	2.13	03
A (SRI AMAR JYOTI KERKETTA)	D1	0.91	2.13	07
A (SRI AMAR JYOTI KERKETTA)	D	1.05	2.13	01

SCHEDULE OF WINDOW/VENTILATION:

BUILDING NAME	NAME	LENGTH	HEIGHT	NOS
A (SRI AMAR JYOTI KERKETTA)	V	0.76	1.00	03
A (SRI AMAR JYOTI KERKETTA)	W1	1.80	2.50	06
A (SRI AMAR JYOTI KERKETTA)	W2	1.80	2.50	01
A (SRI AMAR JYOTI KERKETTA)	W	3.50	2.50	01

UnitBUA Table for Building :A (SRI AMAR JYOTI KERKETTA)

FLOOR	Name	UnitBUA Type	UnitBUA Area	Carpet Area	No. of Rooms	No. of Tenement
GROUND FLOOR PLAN	SPLIT SRI AMAR JYOTI KERKETTA	FLAT	139.44	133.44	10	1
Total:	-	-	139.44	133.44	10	1

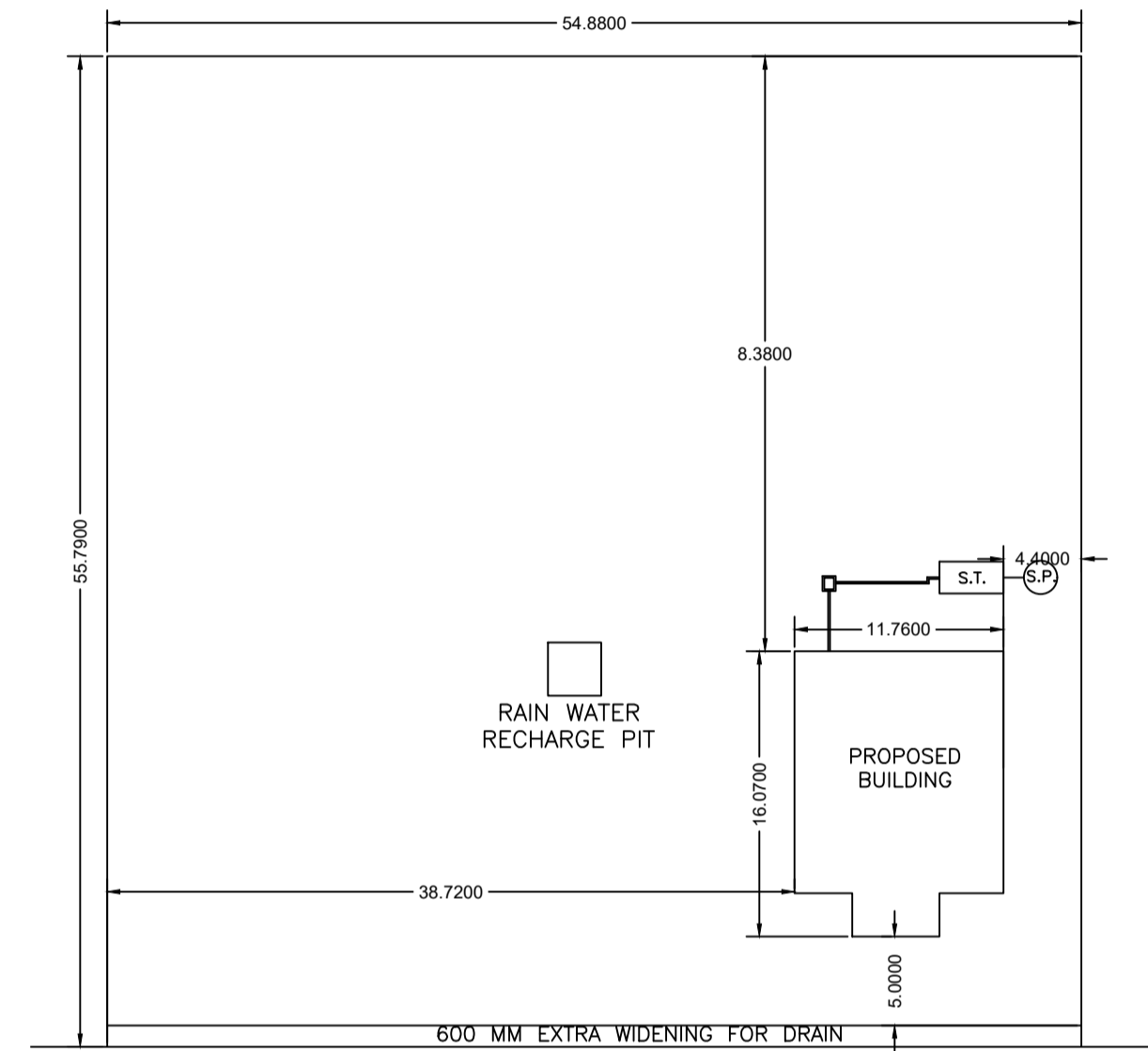
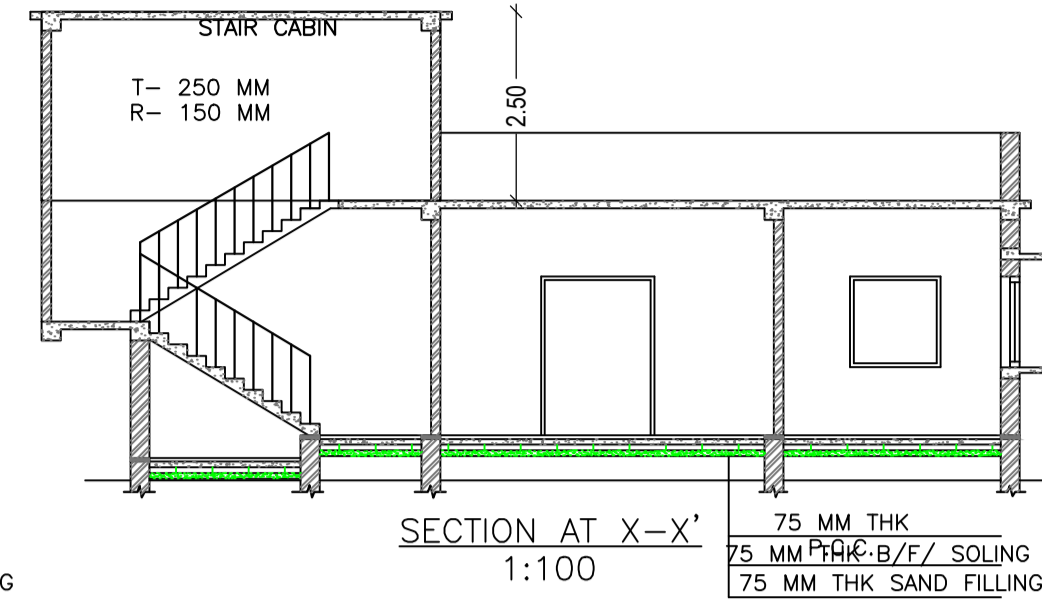
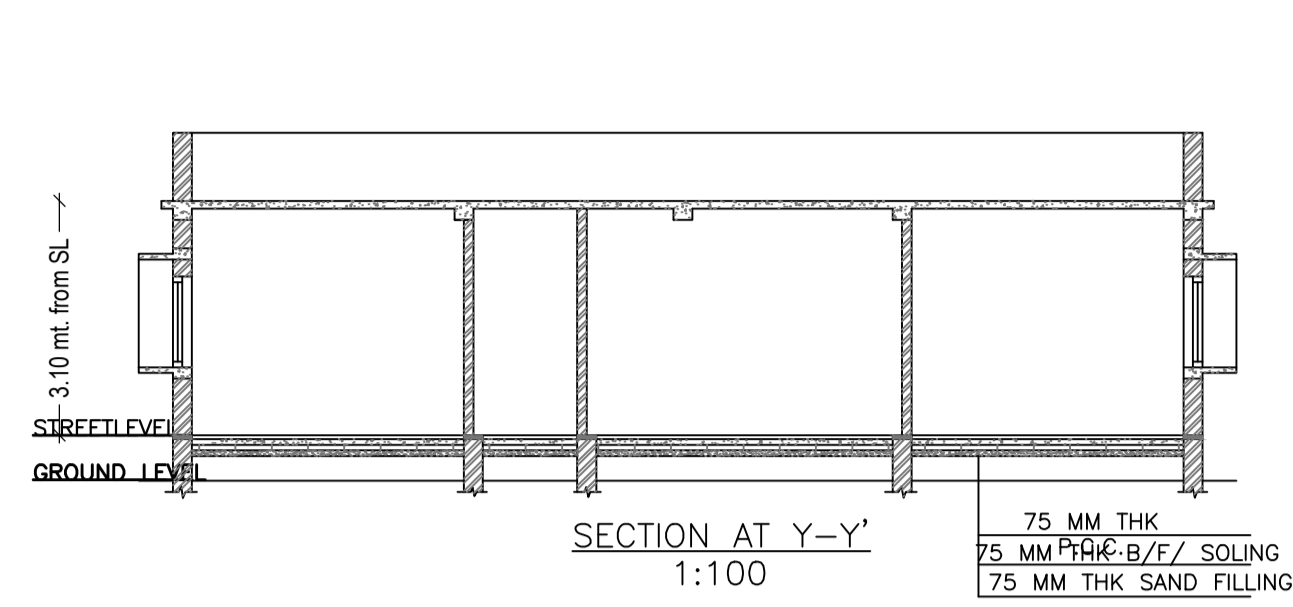

SITE PLAN 1:200



FRONT ELEVATION 1:100

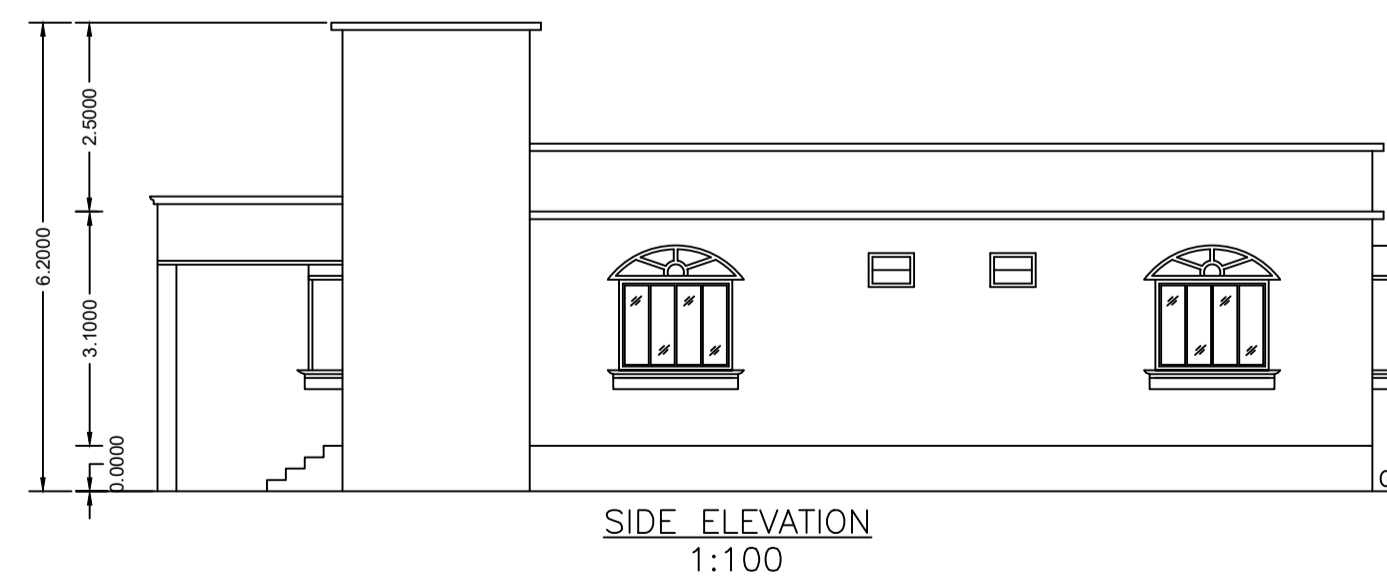

SIDE ELEVATION 1:100

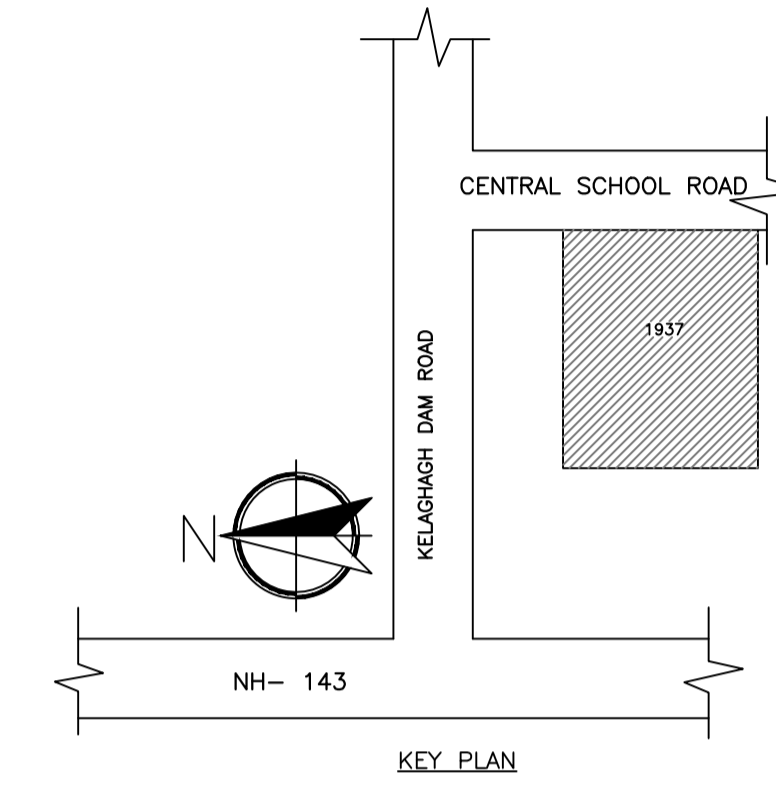

KEY PLAN

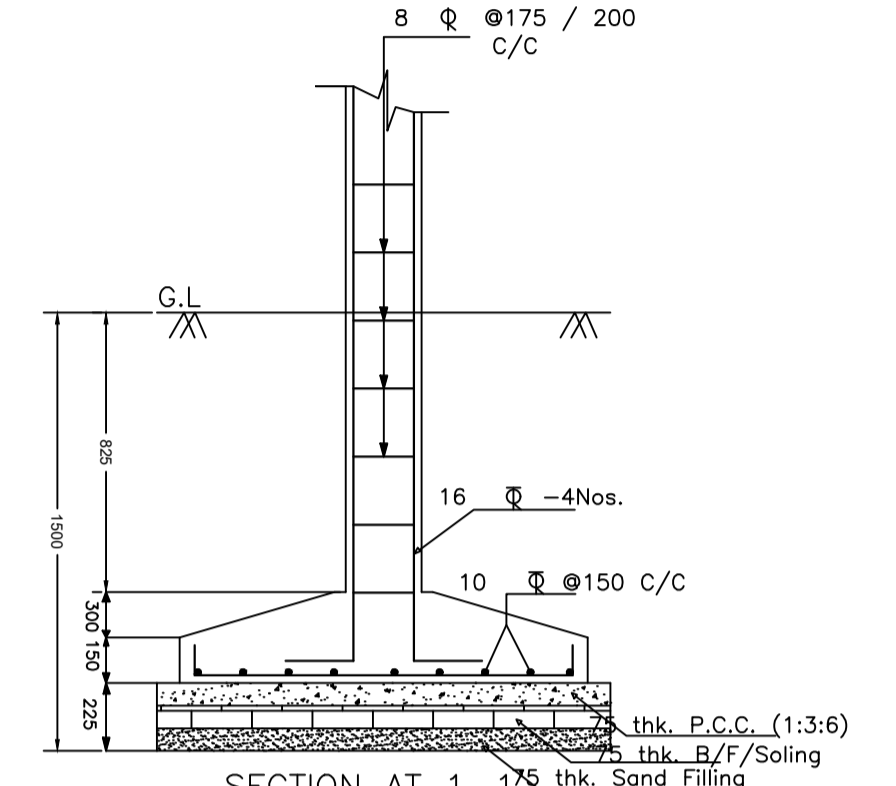

SECTION AT 1-1' 1:25

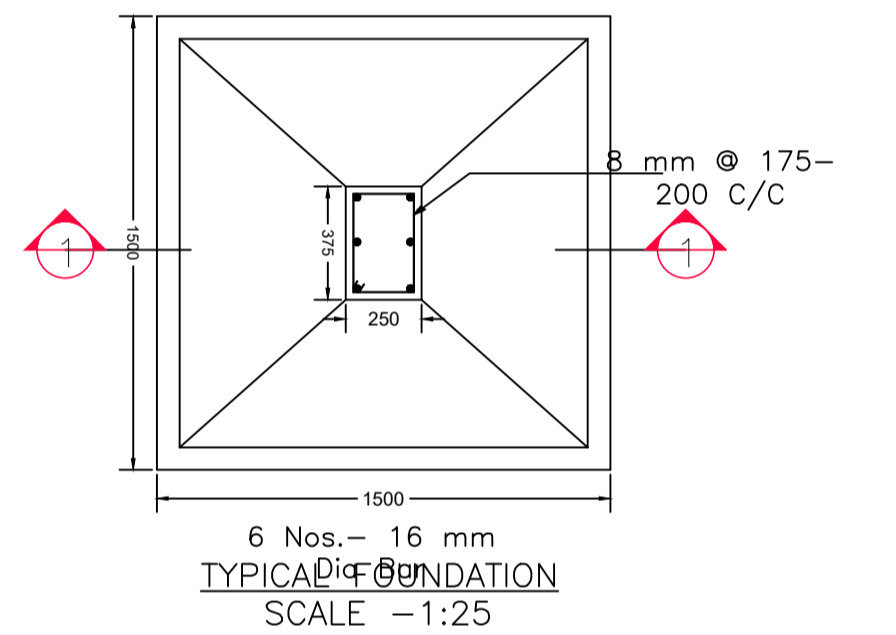

TYPICAL FOUNDATION SCALE - 1:25

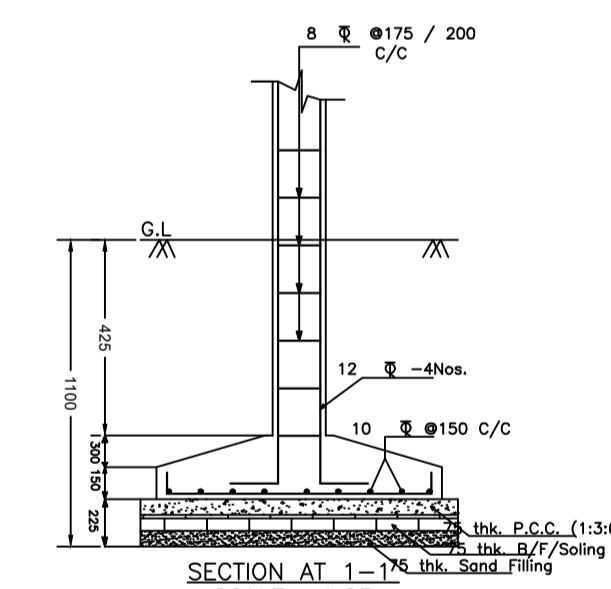

SECTION AT 1-1' 1:25

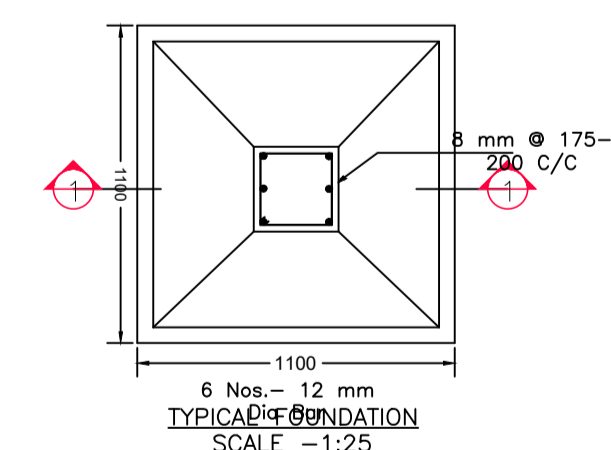

TYPICAL FOUNDATION SCALE - 1:25

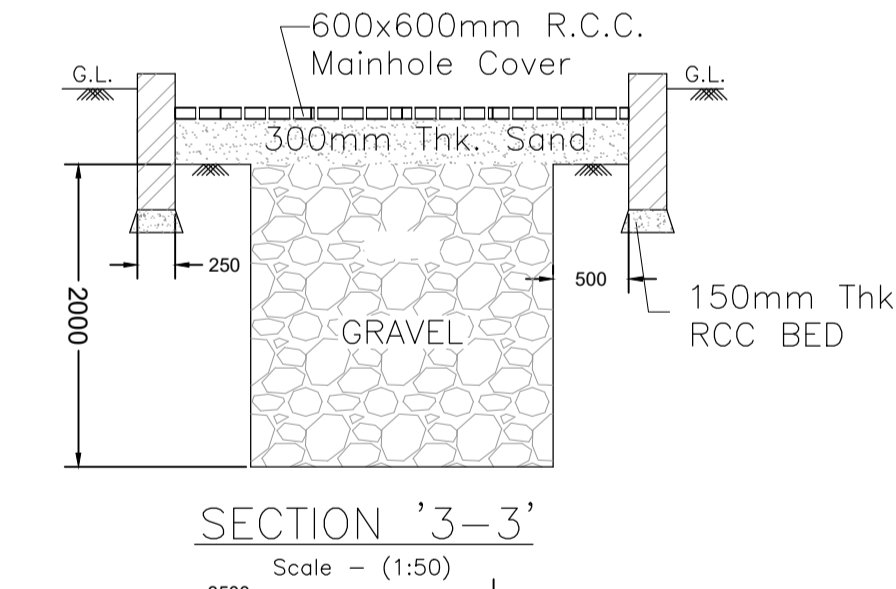

SECTION '3-3' Scale - (1:150)

PLAN OF RAIN WATER RECHARGE PIT Scale - (1:50)

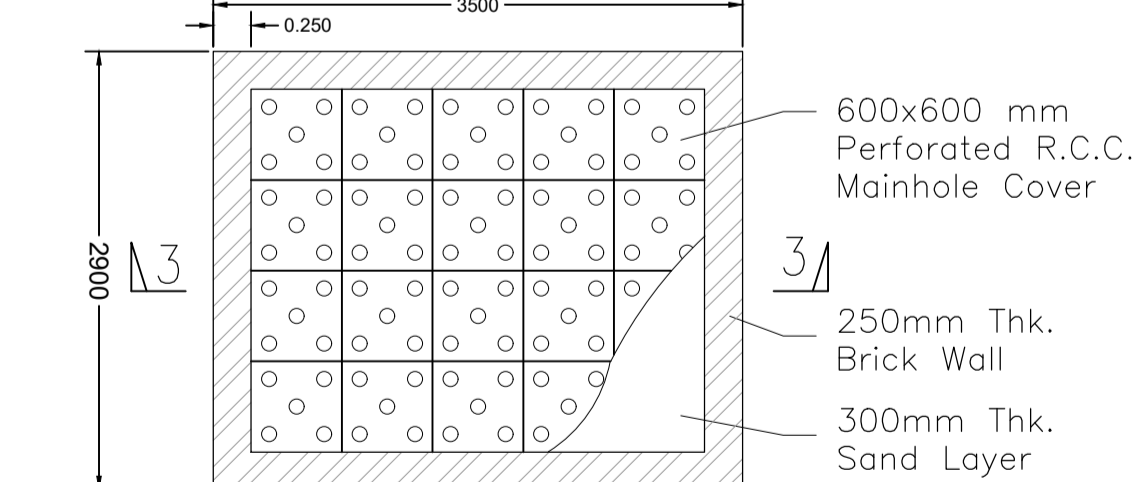

LTP NAME AND SIGNATURE	STRUCTURAL ENG'S NAME AND SIGNATURE	BUILDER NAME AND SIGNATURE
MD RAGIB SAYEED SINPC/ENG/0001/2017		