

**SITE PLAN**  
SCALE 1:100

SITE PLAN

FAR & Tenement Details (Table 4c-1)

Building	No. of Same Bldg	Total Built Up Area (Sq.mt.)	Deductions (Area in Sq.mt.)		Proposed FAR Area (Sq.mt.)	Total FAR Area (Sq.mt.)	Total Consumed Additional FAR Area (Sq.mt.)	Trmnt (No.)
			Void	Resi.				
A1 (BUILDING)	1	104.08	4.98	99.10	99.10	99.10	02	
<b>Grand Total :</b>	<b>1</b>	<b>104.08</b>	<b>4.98</b>	<b>99.10</b>	<b>99.10</b>	<b>99.10</b>	<b>02</b>	

Proposal Basic Information

Proposal File No.	SINPC/BP/0046/W14/2018
Owner Name	SANJAY KUMAR GUPTA
Khata No	2
Plot No	629
Village Name	Saldega
Use	Residential
SubUse	Residential Bldg/Apartment

Required Parking (Table 7a)

Building Name	Type	SubUse	Area (Sq.mt.)	Units		Car		Visitors Car		TwoWheeler	
				Regd.	Prop.	Regd./Unit	Prop.	Regd./Unit	Prop.	Regd./Unit	Prop.
A1 (BUILDING)	Residential	Residential Bldg/Apartment	> 0	1	2.00	1	2	-	-	-	-
			> 0	1	2.00	-	-	-	-	1	2
<b>Total :</b>							2	3		1	2

Parking Check (Table 7b)

Vehicle Type	Reqd.		Prop.	
	No.	Area	No.	Area
Car	-	-	3	37.50
Total Car	2	25.00	3	37.50
Visitor's Car Parking	1	12.50	2	25.00
TwoWheeler	2	4.00	6	12.00
Other Parking	-	-	-	7.79
<b>Total</b>		<b>41.50</b>		<b>82.29</b>

AREA STATEMENT SIMDEGA NAGAR PANCHAYAT	VERSION NO. : 1.0.27
PROJECT DETAIL:	VERSION DATE: 18/05/2018
Region: JHARKHAND URBAN LOCAL BODIES	Plot Use: Residential
District: SIMDEGA	Plot SubUse: Residential Bldg/Apartment
Authority: SIMDEGA NAGAR PANCHAYAT	PlotNearbyReligiousStructure: NA
Inward No: SINPC/BP/0046/W14/2018	PlotSubPlot No: 629
Application Type: General Proposal	North: -
Project Type: Building Permission	South: -
Nature of Development: New	East: -
Location of Development Area: New Area	West: -
AREA DETAILS:	SQ.MT.
AREA OF PLOT (Minimum)	(A) 121.24
Deduction for NetPlot Area	
Surrender Free of Cost	17.17
Total	17.17
NET AREA OF PLOT(Gross Plot Area - Deduction from Gross Plot area)	(A-Deductions) 104.07
Deduction for Balance Plot Area(from Gross Plot Area)	
Surrender Free of Cost	17.17
Common Plot	20.10
Total	37.27
BALANCE AREA OF PLOT(Net Plot Area - Recreational/Amenity space)	(A-Deductions) 83.97
PLOT AREA FOR COVERAGE(Net Plot Area)	(A-Deductions) 104.07
Plot Area for FAR (Net Plot Area + RoadWidening Area)	(A-Deductions) 121.24
COVERAGE CHECK	
Permissible Coverage area ( 70.00 % )	72.85
Proposed Coverage Area ( 50.00 % )	52.04
Total Prop. Coverage Area ( 50 % )	52.04
Balance coverage area ( 20.00 % )	20.81
FAR CHECK	
Perm. FAR Area ( 1.50 )	181.86
Total Perm. FAR area	181.86
Residential FAR	99.10
Proposed FAR Area	99.10
Total Proposed FAR Area	99.10
Consumed FAR (Factor)	0.82
Balance FAR Area	82.76
BUILT UP AREA CHECK	
Total Proposed BuiltUp Area	104.08
ARCHITECT (Regd)	RAJESH KUMAR
ENGINEER (Regd)	
SUPERVISOR (Regd)	
OWNER (Regd)	SANJAY KUMAR GUPTA
DEVELOPMENT AUTHORITY	LOCAL BODY

COLOR INDEX	
PLOT BOUNDARY	Black
ABUTTING ROAD	Green
PROPOSED CONSTRUCTION	Red
COMMON PLOT	Yellow
ROAD WIDENING AREA	Blue
EXISTING (To be retained)	Blue
EXISTING (To be demolished)	Yellow

Buildingwise Floor FAR Details

Floor Name	Building Name A1 (BUILDING)		Total	
	Proposed Built Up Area (Sq.mt.)	Proposed FAR Area (Sq.mt.)	Total Proposed Built Up Area (Sq.mt.)	Total FAR Area (Sq.mt.)
Ground Floor	52.04	49.55	52.04	49.55
First Floor	52.04	49.55	52.04	49.55
Terrace Floor	0.00	0.00	0.00	0.00
<b>Total :</b>	<b>104.08</b>	<b>99.10</b>	<b>104.08</b>	<b>99.10</b>

Building USE/SUBUSE Details

Building Name	Building Use	Building SubUse	Building Structure
A1 (BUILDING)	Residential	Residential Bldg/Apartment	Non-Highrise

LTP NAME AND SIGNATURE	STRUCTURAL ENG'S NAME AND SIGNATURE	BUILDER NAME AND SIGNATURE
RAJESH KUMAR SINPC/DFTMN/0008/2017		

Proposal Basic Information	
Proposal File No.	SINPC/BP/0046/W14/2018
Owner Name	SANJAY KUMAR GUPTA
Khata No	2
Plot No	629
Village Name	Saldega
Use	Residential
SubUse	Residential Bldg/Apartment

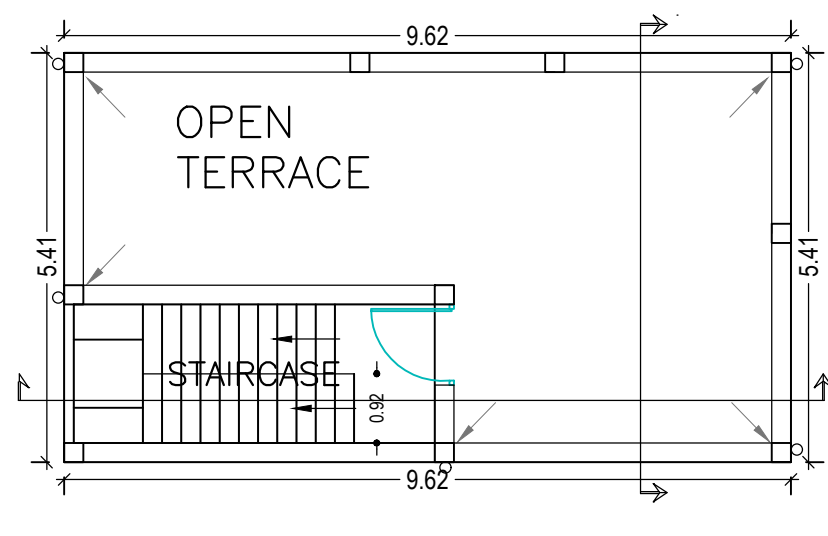
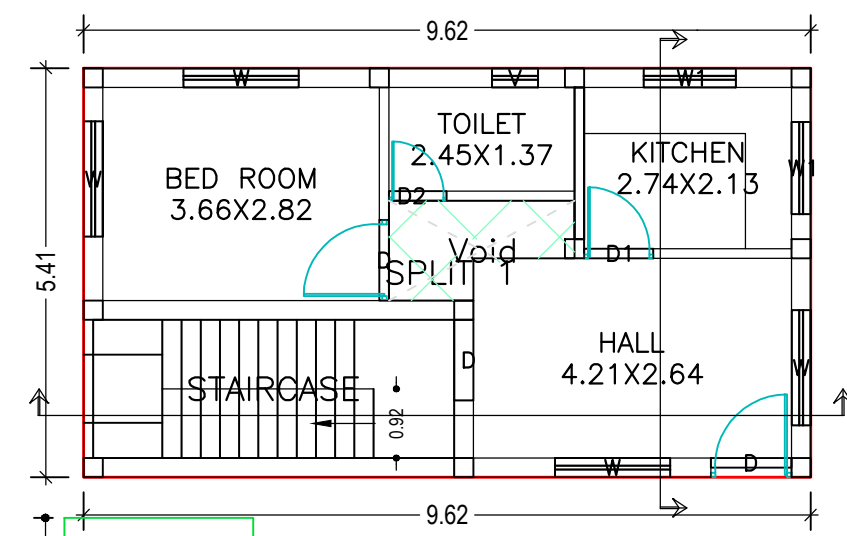

TERRACE FLOOR PLAN (SCALE 1:100)

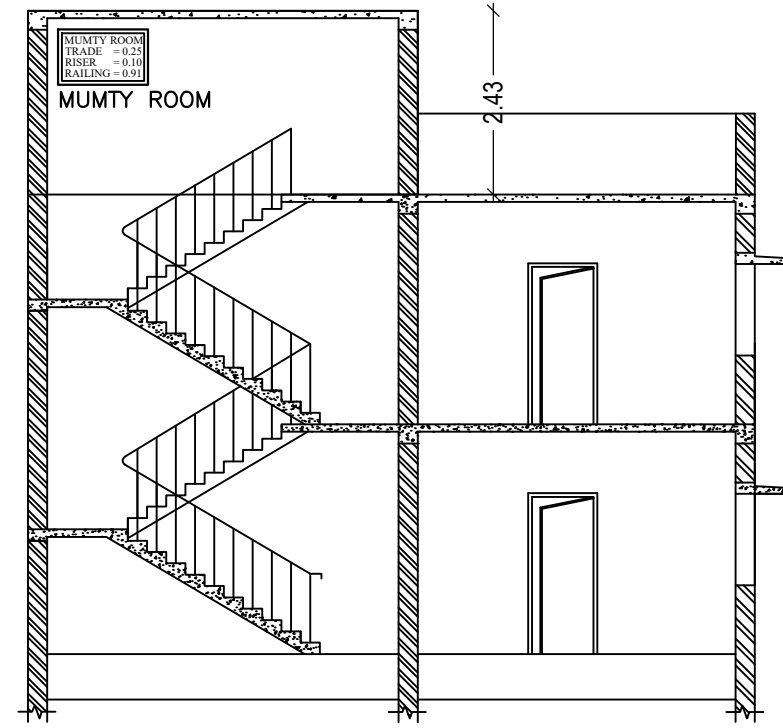
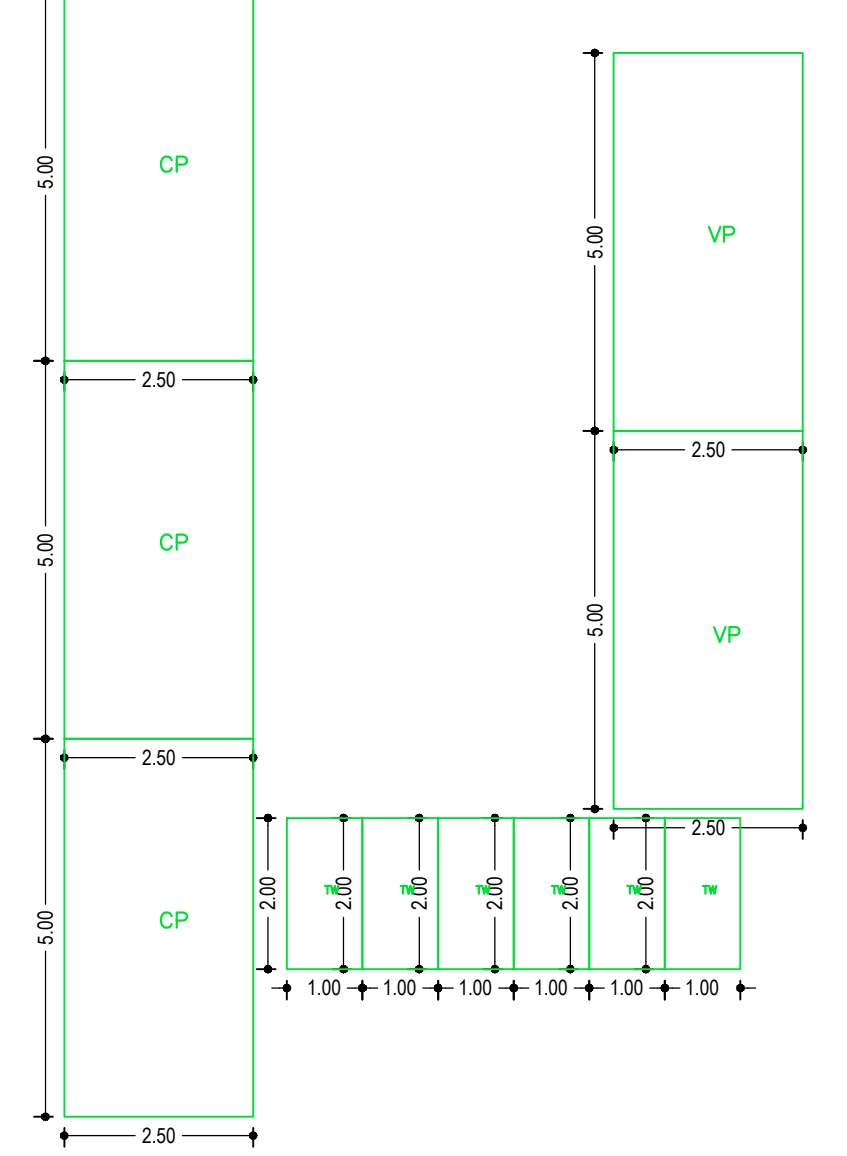

SECTION ON SCALE 1:100

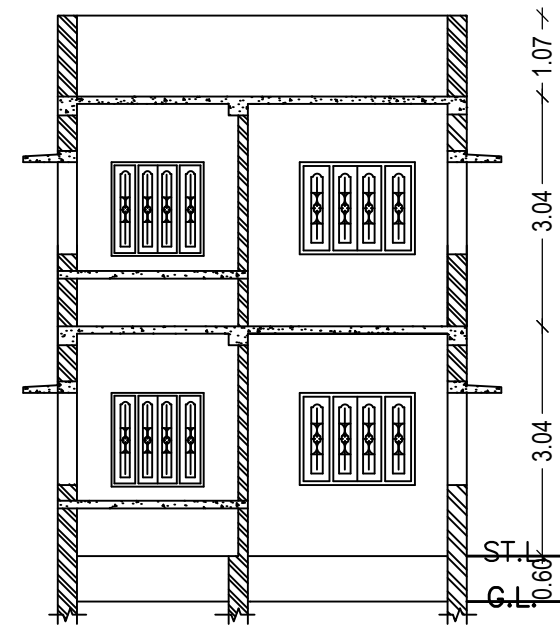

SECTION ON SCALE 1:100

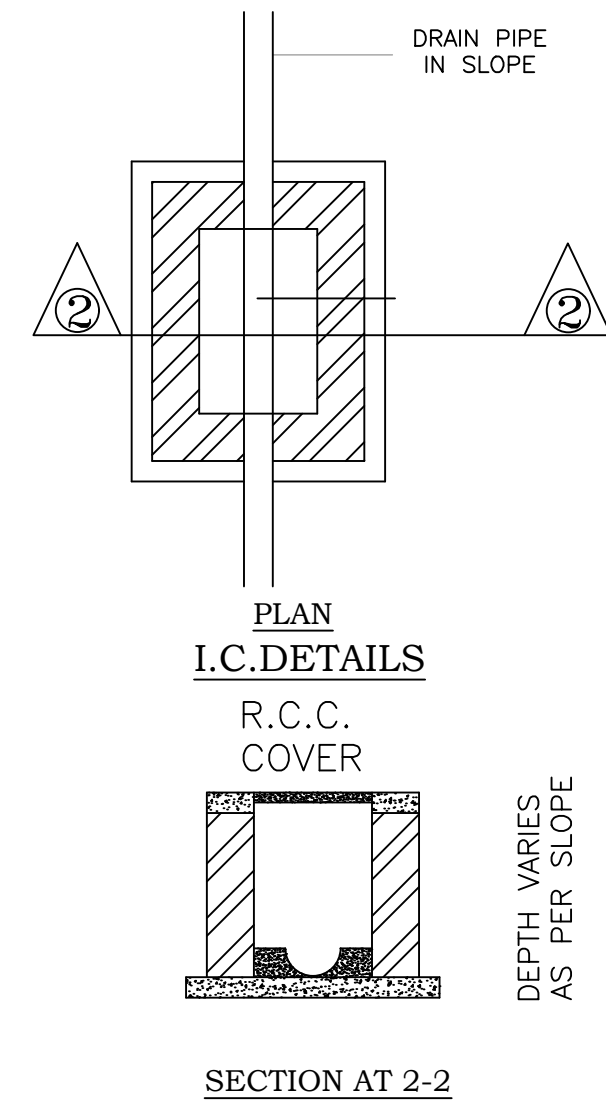

PLAN I.C. DETAILS R.C.C. COVER

SECTION AT 2-2

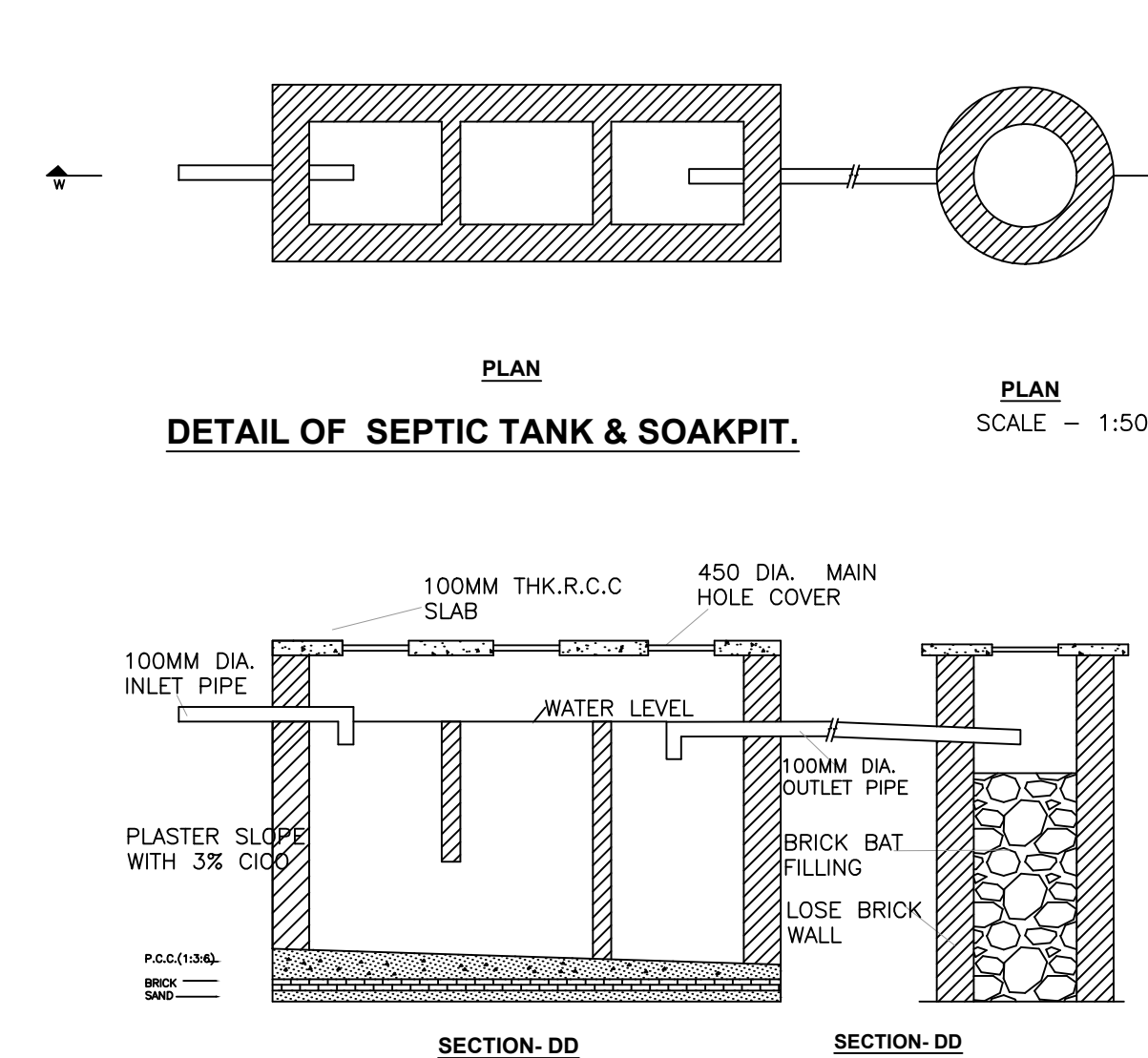

DETAIL OF SEPTIC TANK & SOAKPIT.

SECTION-DD

SECTION-DD

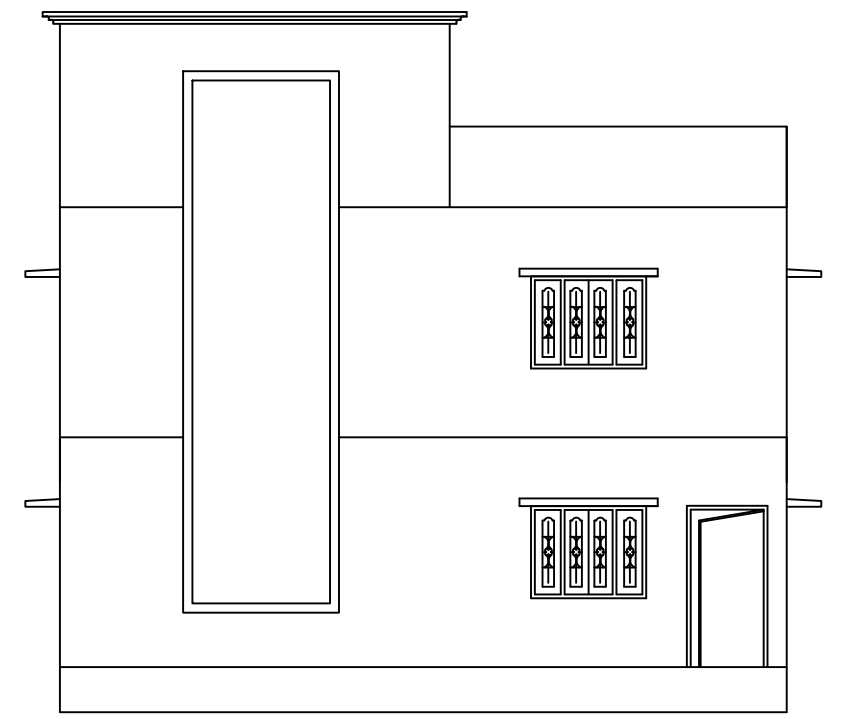

FRONT ELEVATION SCALE 1:100

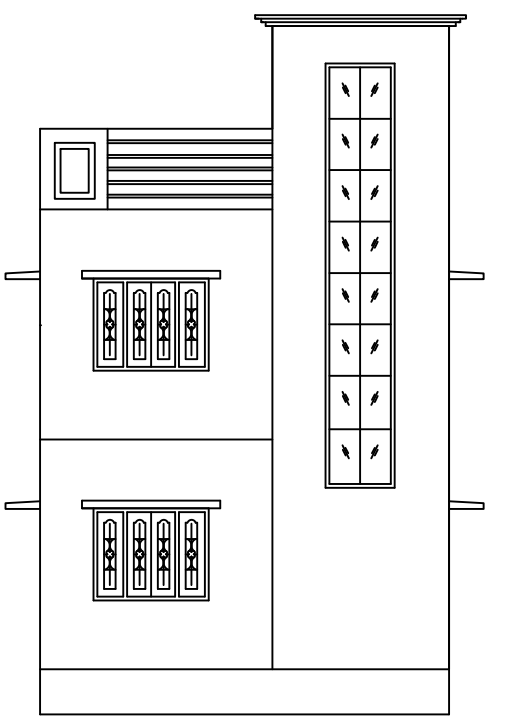

LEFT SIDE ELEVATION SCALE 1:100

GROUND FLOOR PLAN (Proposed) (SCALE 1:100)

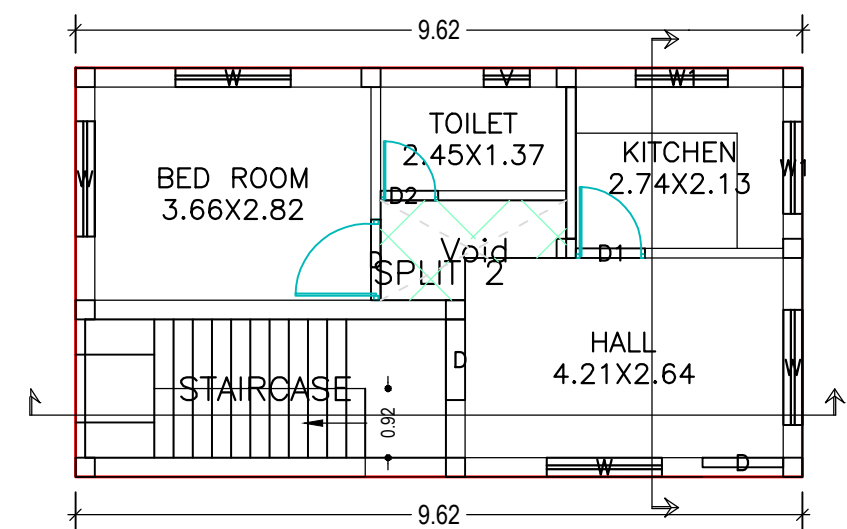

FIRST FLOOR PLAN (Proposed) (SCALE 1:100)

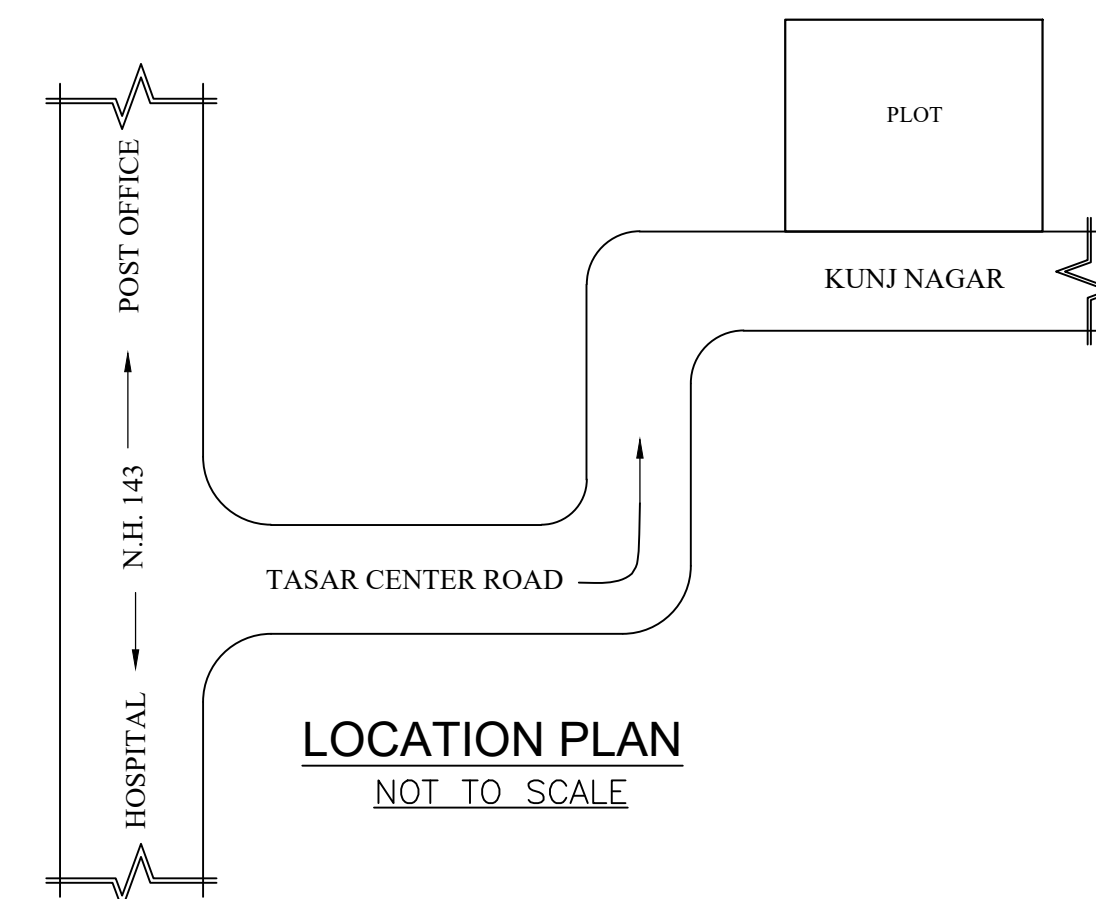

LOCATION PLAN NOT TO SCALE

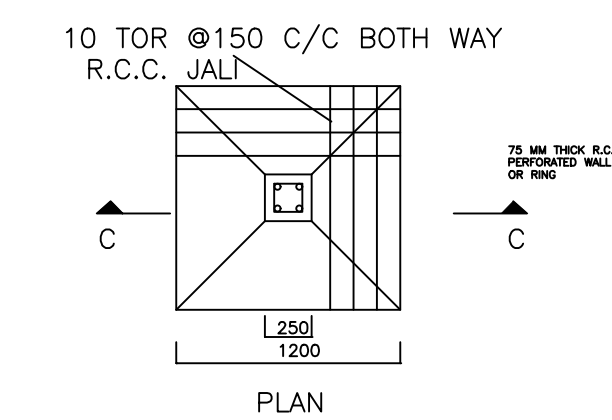

DETAIL OF FOUNDATION

SCALE:- 1:50

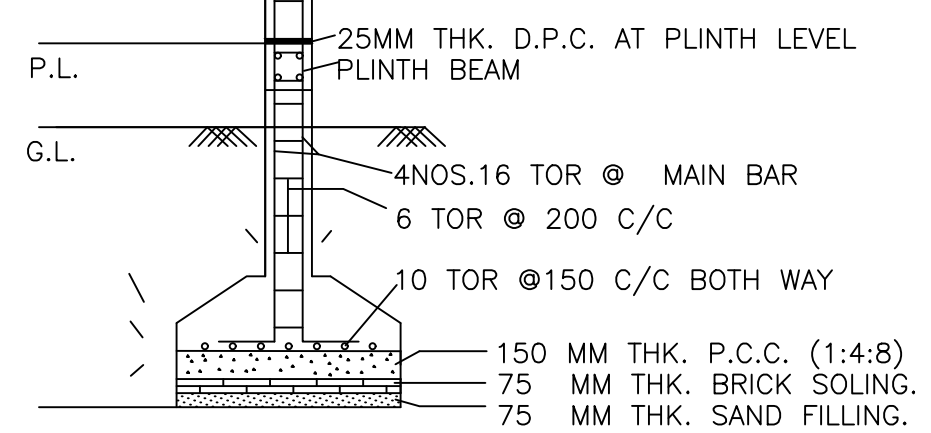

SECTION -CC

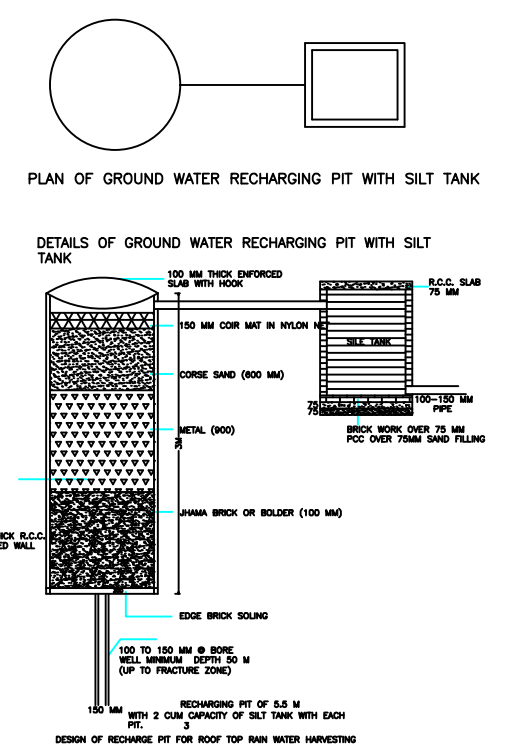

Building :A1 (BUILDING)

Floor Name	Total Built Up Area (Sq.mt.)	Deductions (Area in Sq.mt.)	Proposed FAR Area (Sq.mt.)	Total FAR Area (Sq.mt.)	Total Consumed Additional FAR Area (Sq.mt.)	Trmt (No.)
Ground Floor	52.04	2.49	49.55	49.55	49.55	01
First Floor	52.04	2.49	49.55	49.55	49.55	01
Terrace Floor	0.00	0.00	0.00	0.00	0.00	00
Total:	104.08	4.98	99.10	99.10	99.10	02
Total Number of Same Buildings	1					
Total:	104.08	4.98	99.10	99.10	99.10	02

SCHEDULE OF DOOR:

BUILDING NAME	NAME	LENGTH	HEIGHT	NOS
A1 (BUILDING)	D2	0.76	2.10	02
A1 (BUILDING)	D1	0.91	2.10	02
A1 (BUILDING)	D	1.07	2.10	06

SCHEDULE OF WINDOW/VENTILATION:

BUILDING NAME	NAME	LENGTH	HEIGHT	NOS
A1 (BUILDING)	V	0.61	1.20	02
A1 (BUILDING)	W1	1.22	1.20	04
A1 (BUILDING)	W	1.52	1.20	08

UnitBUA Table for Building :A1 (BUILDING)

FLOOR	Name	UnitBUA Type	UnitBUA Area	Carpet Area	No. of Rooms	No. of Tenement
GROUND FLOOR PLAN	SPLIT 1	FLAT	31.95	31.70	4	1
FIRST FLOOR PLAN	SPLIT 2	FLAT	31.95	31.70	4	1
Total:	-	-	63.90	63.40	8	2

LTP NAME AND SIGNATURE	STRUCTURAL ENG'S NAME AND SIGNATURE	BUILDER NAME AND SIGNATURE
RAJESH KUMAR SINPC/DFTMN/0008/2017		