

SITE PLAN (Scale - 1:200)

FAR & Tenement Details (Table 4c-1)

Building	No. of Same Bldg	Total Built Up Area (Sq.mt.)	Deductions (Area in Sq.mt.)		Proposed FAR Area (Sq.mt.)	Total FAR Area (Sq.mt.)	Total Consumed Additional FAR Area (Sq.mt.)	Trmnt (No.)
			Void	Resi.				
A1 (BUILDING)	1	255.61	17.51	-	238.10	238.10	238.10	02
Grand Total :	1	255.61	17.51	-	238.10	238.10	238.10	02

Proposal Basic Information

Proposal File No.	SINPC/BP/0068/W02/2018
Owner Name	SOBHNATH SAHU
Khata No	103
Plot No	2530
Village Name	Gotra
Use	Residential
SubUse	Residential Bldg/Apartment

Required Parking (Table 7a)

Building Name	Type	SubUse	Area (Sq.mt.)	Units		Car		Visitors Car		TwoWheeler	
				Regd.	Prop.	Regd./Unit	Prop.	Regd./Unit	Prop.	Regd./Unit	Prop.
A1 (BUILDING)	Residential	Residential Bldg/Apartment	> 0	1	2.00	1	2	-	-	-	-
			> 0	1	2.00	-	-	-	-	1	2
			> 0	1	2.00	-	-	1	1	-	-
Total :			-	-	-	-	2	4	-	1	2

Parking Check (Table 7b)

Vehicle Type	Reqd.		Prop.	
	No.	Area	No.	Area
Car	-	-	4	50.00
Total Car	2	25.00	4	50.00
Visitor's Car Parking	1	12.50	1	12.50
TwoWheeler	2	4.00	6	12.00
Other Parking	-	-	-	156.44
Total		41.50		230.94

AREA STATEMENT SIMDEGA NAGAR PANCHAYAT	VERSION NO. : 1.0.29		
	VERSION DATE: 30/06/2018		
PROJECT DETAIL:			
Region: JHARKHAND URBAN LOCAL BODIES	Plot Use: Residential		
District: SIMDEGA	Plot SubUse: Residential Bldg/Apartment		
Authority: SIMDEGA NAGAR PANCHAYAT	PlotNearbyReligiousStructure: NA		
Inward No: SINPC/BP/0068/W02/2018	PlotSubPlot No: 2530		
Application Type: General Proposal	North: -		
Project Type: Building Permission	South: -		
Nature of Development: New	East: -		
Location of Development Area: New Area	West: -		
AREA DETAILS:			
AREA OF PLOT (Minimum)	(A)	SQ.MT.	606.92
Deduction for NetPlot Area			
Road Widening Area			17.22
Total			17.22
NET AREA OF PLOT(Gross Plot Area - Deduction from Gross Plot area)	(A-Deductions)		588.70
Deduction for Balance Plot Area(from Gross Plot Area)			
Road Widening Area			17.22
Common Plot			151.69
Total			168.91
BALANCE AREA OF PLOT(Net Plot Area - Recreational/Amenity space)	(A-Deductions)		437.01
PLOT AREA FOR COVERAGE(Net Plot Area)	(A-Deductions)		588.70
Plot Area for FAR (Net Plot Area + RoadWidening Area)	(A-Deductions)		588.70
COVERAGE CHECK			
Permissible Coverage area (60.00 %)			353.22
Proposed Coverage Area (21.71 %)			127.81
Total Prop. Coverage Area (21.71 %)			127.81
Balance coverage area (38.29 %)			225.41
FAR CHECK			
Perm. FAR Area (1.50)			883.05
Total Perm. FAR area			883.05
Residential FAR			238.10
Proposed FAR Area			238.10
Total Proposed FAR Area			238.10
Consumed FAR (Factor)			0.40
Balance FAR Area			644.95
BUILT UP AREA CHECK			
Total Proposed BuiltUp Area			255.61
ARCHITECT (Regd)			RAJESH KUMAR
ENGINEER (Regd)			
SUPERVISOR (Regd)			
OWNER (Regd)			SOBHNATH SAHU
DEVELOPMENT AUTHORITY			LOCAL BODY

COLOR INDEX	
PLOT BOUNDARY	Black
ABUTTING ROAD	Green
PROPOSED CONSTRUCTION	Red
COMMON PLOT	Yellow
ROAD WIDENING AREA	Orange
EXISTING (To be retained)	Blue
EXISTING (To be demolished)	Light Blue

Buildingwise Floor FAR Details

Floor Name	Building Name		Total	
	Proposed Built Up Area (Sq.mt.)	Proposed FAR Area (Sq.mt.)	Total Proposed Built Up Area (Sq.mt.)	Total FAR Area (Sq.mt.)
Ground Floor	127.80	119.54	127.80	119.54
First Floor	127.81	118.56	127.81	118.56
Terrace Floor	0.00	0.00	0.00	0.00
Total :	255.61	238.10	255.61	238.10

Building USE/SUBUSE Details

Building Name	Building Use	Building SubUse	Building Structure

LTP NAME AND SIGNATURE	STRUCTURAL ENG'S NAME AND SIGNATURE	BUILDER NAME AND SIGNATURE
RAJESH KUMAR SINPC/DFTMN/0068/2017		

Proposal Basic Information	
Proposal File No.	SINPC/BP/0058/W02/2018
Owner Name	SOBHNATH SAHU
Khata No	103
Plot No	2530
Village Name	Goira
Use	Residential
SubUse	Residential Bldg/Apartment

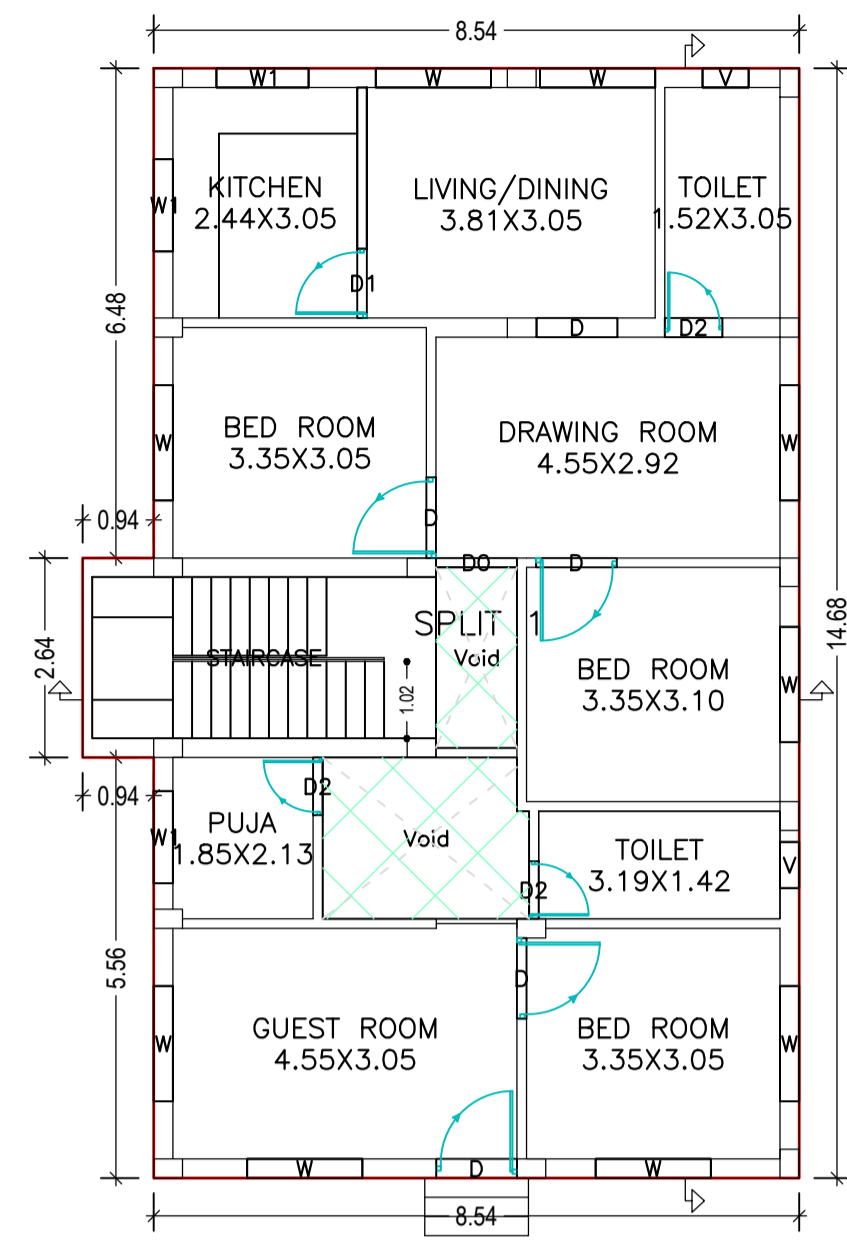

FIRST FLOOR PLAN (Proposed) (SCALE 1:100)

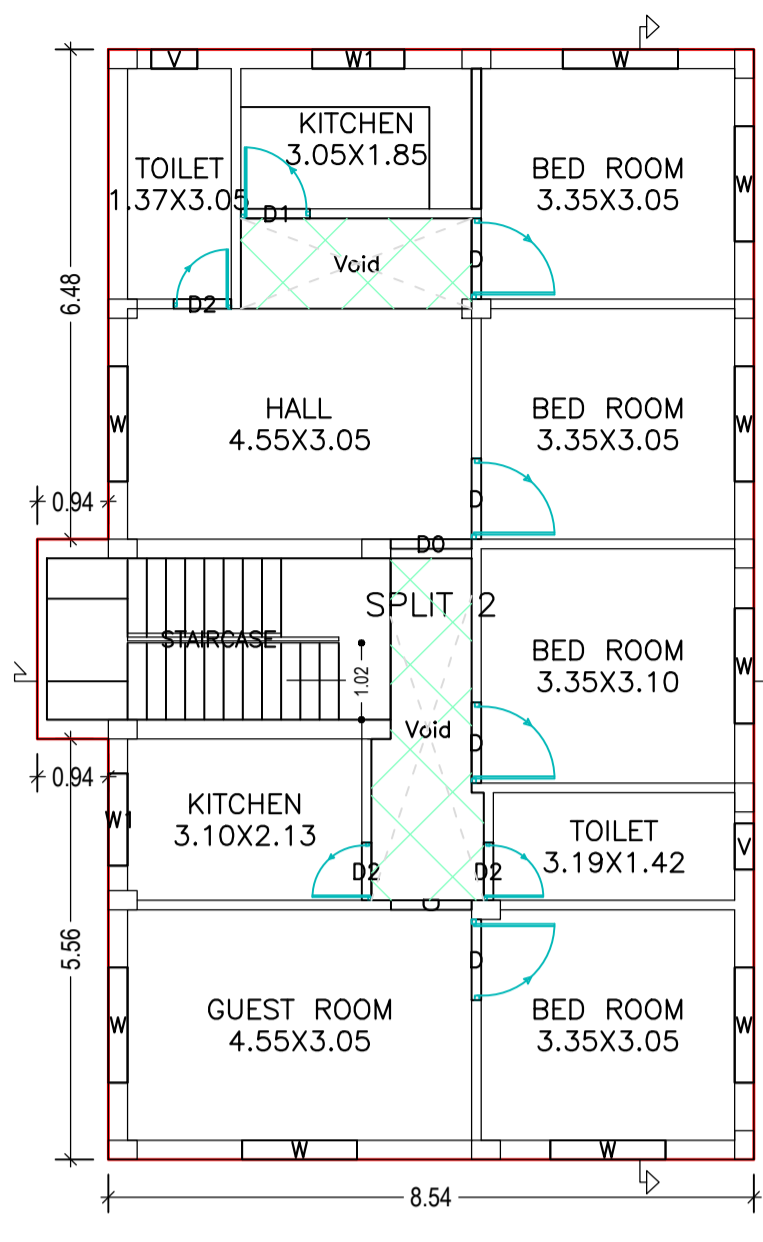

TERRACE FLOOR PLAN (SCALE 1:100)

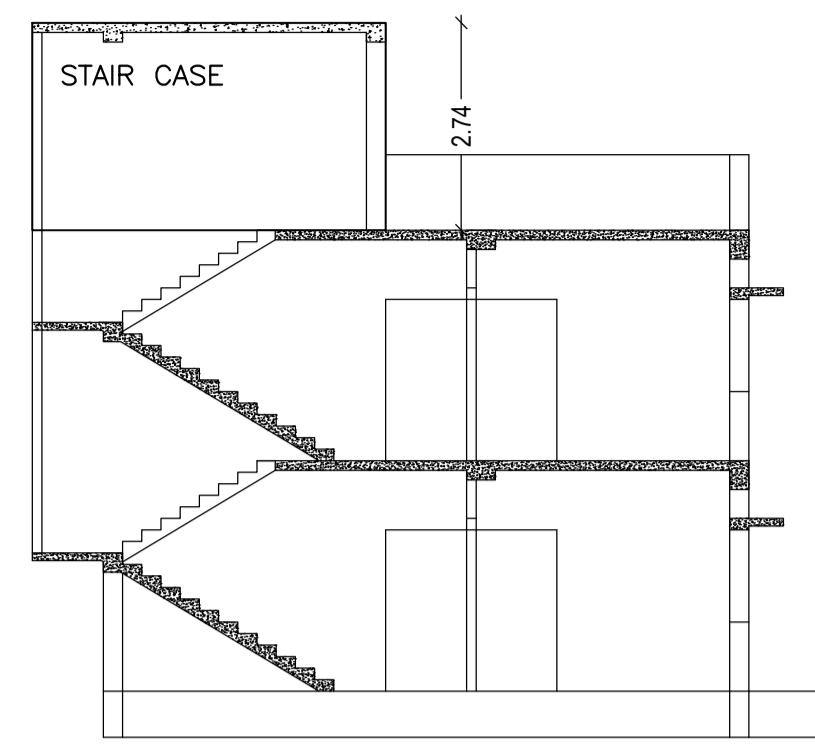

SECTION ON X-X (SCALE 1:100)

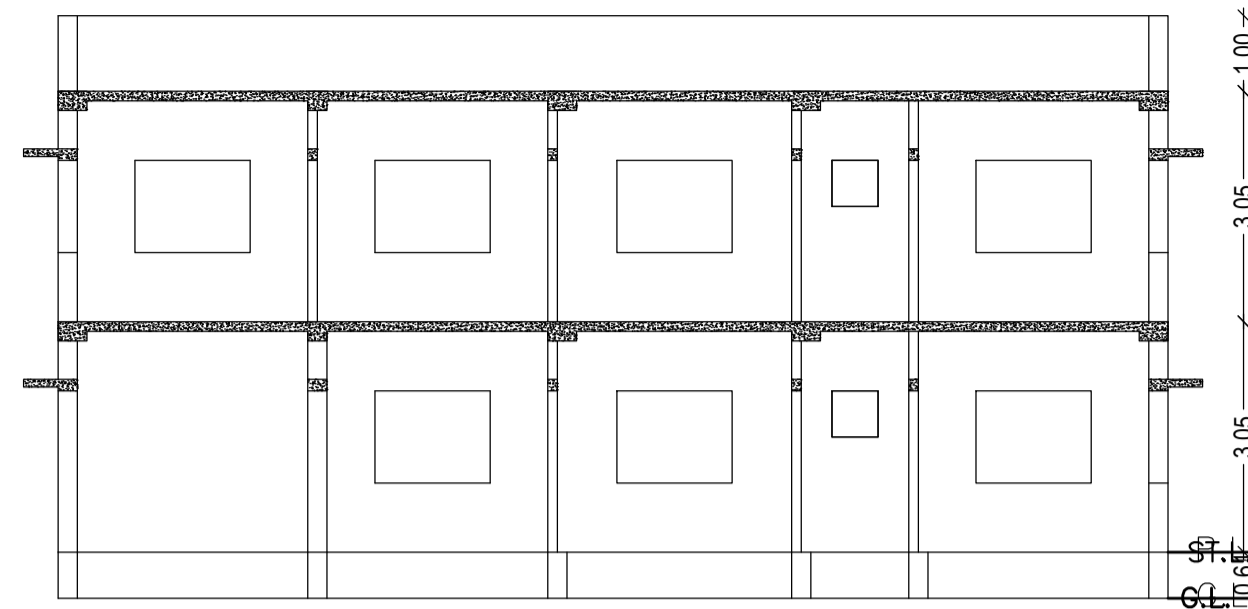

SECTION ON Y-Y (SCALE 1:100)

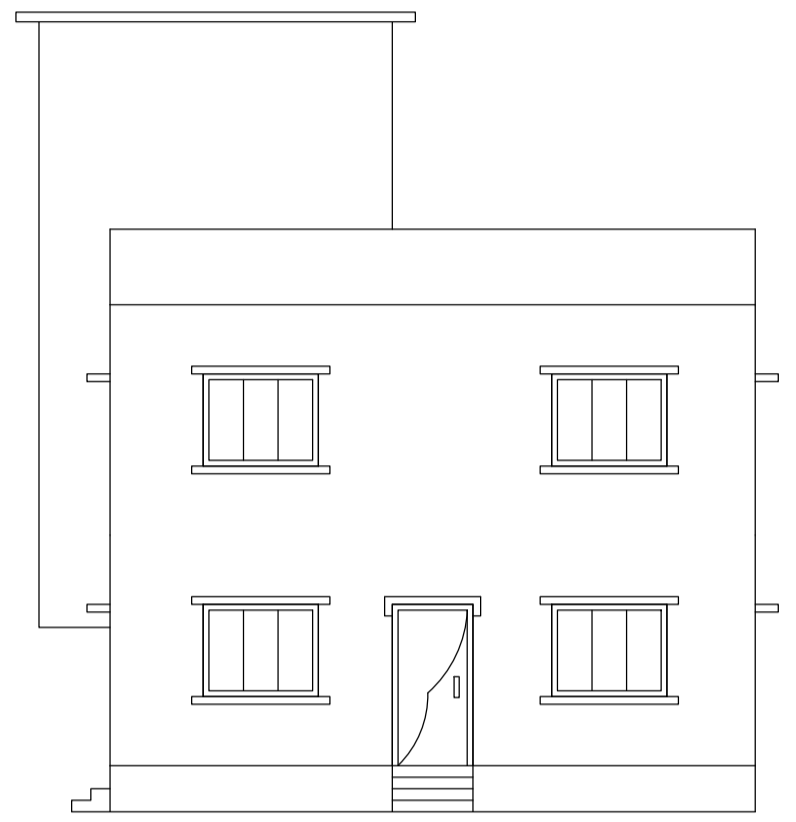

FRONT ELEVATION (SCALE 1:100)

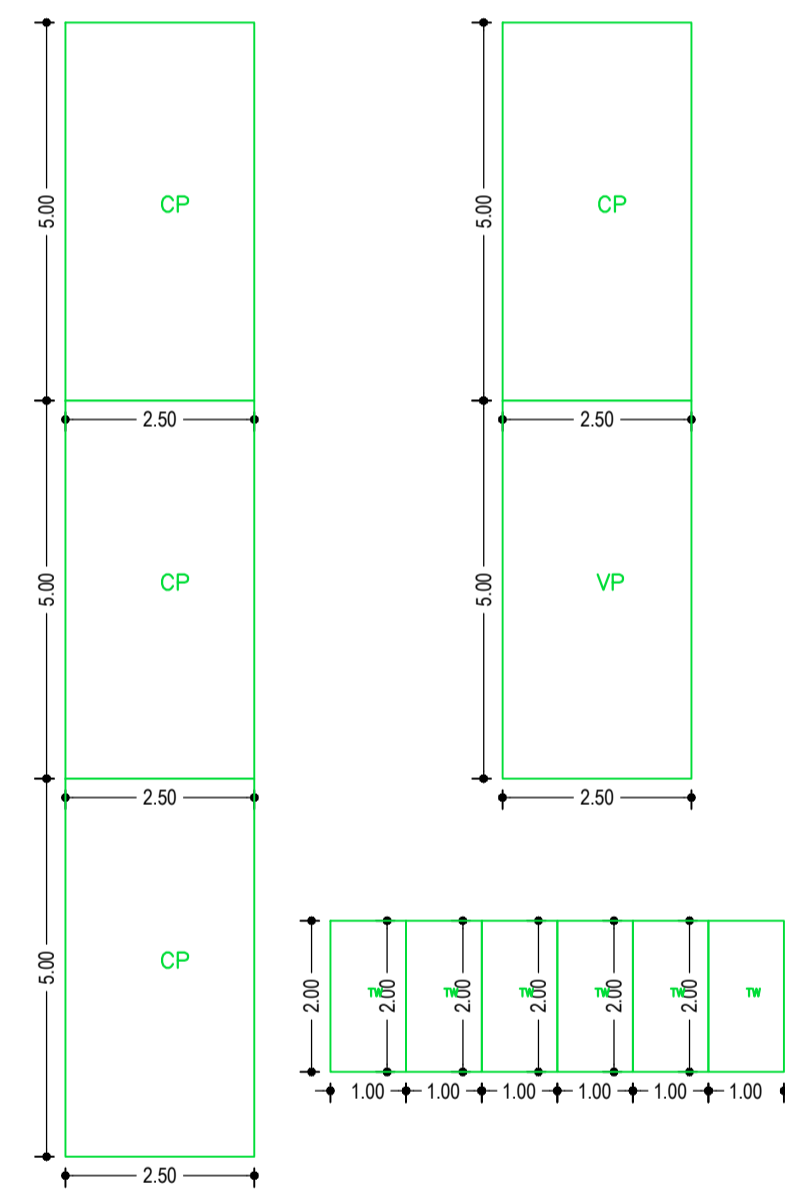

GROUND FLOOR PLAN (Proposed) (SCALE 1:100)

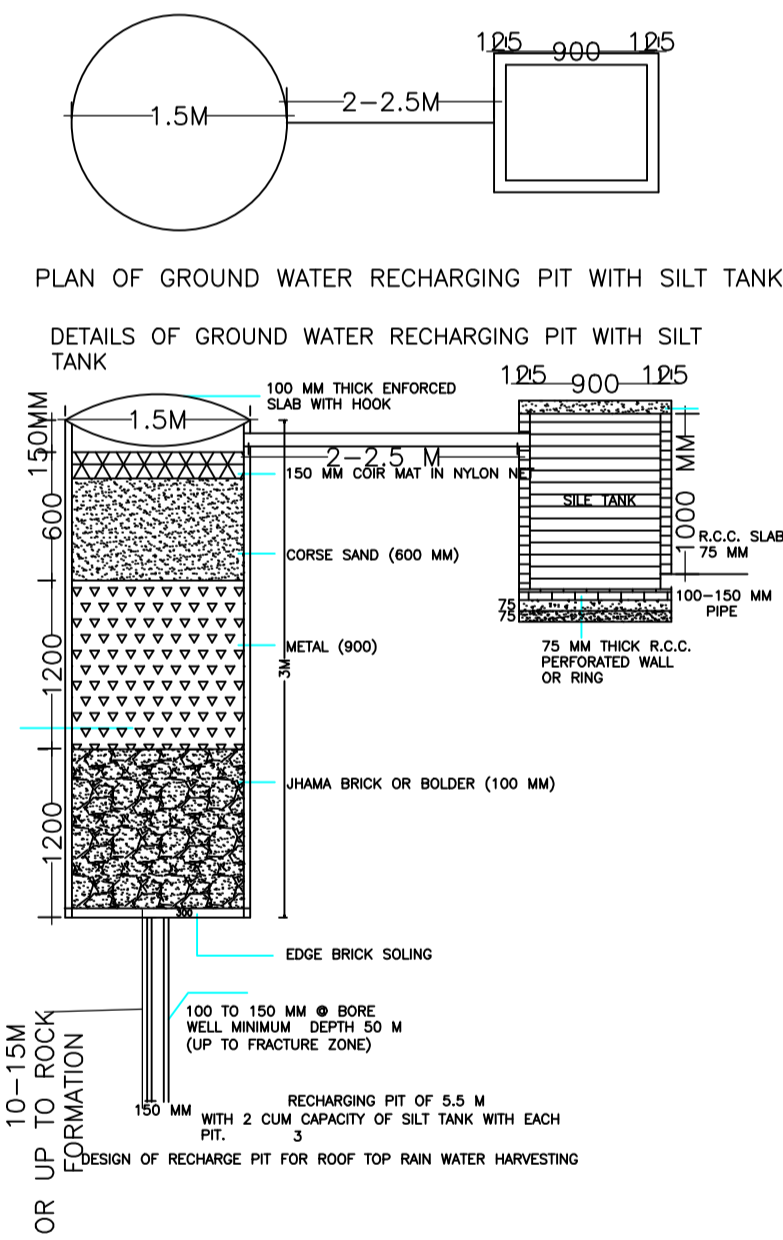

PLAN OF GROUND WATER RECHARGING PIT WITH SILT TANK

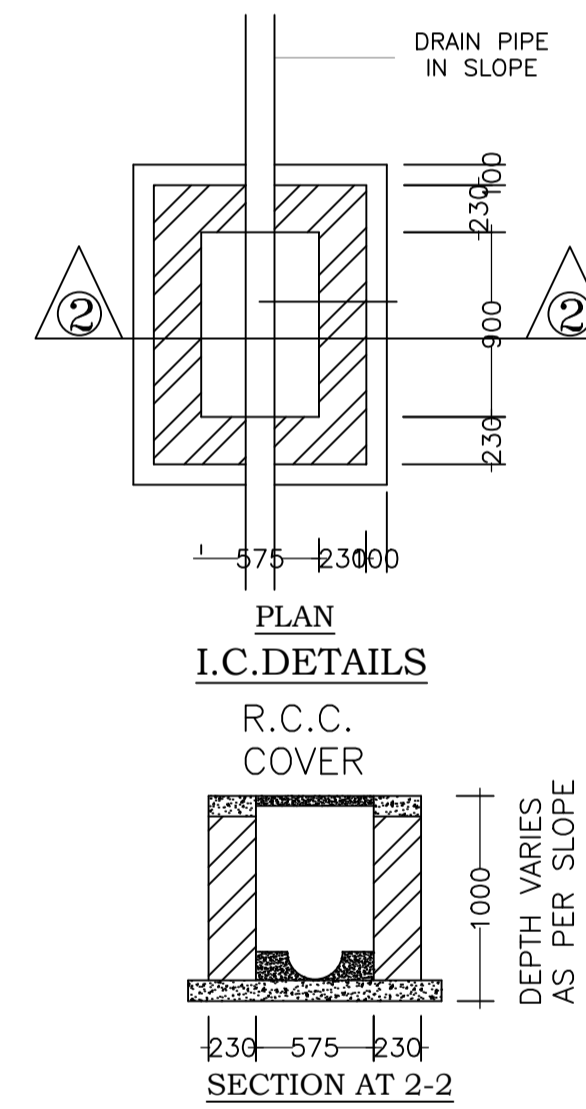

I.C. DETAILS R.C.C. COVER

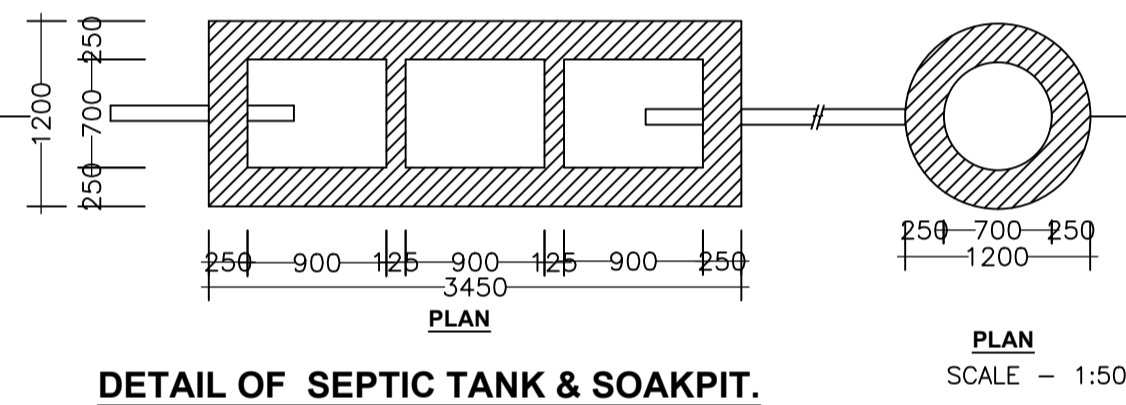

DETAIL OF SEPTIC TANK & SOAKPIT.

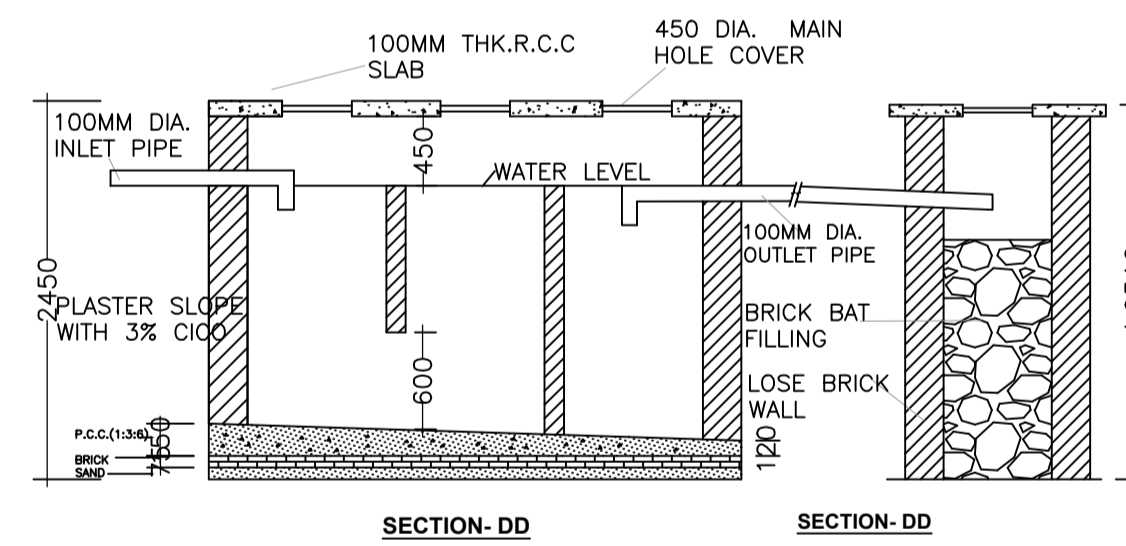

SECTION-DD

SECTION-DD

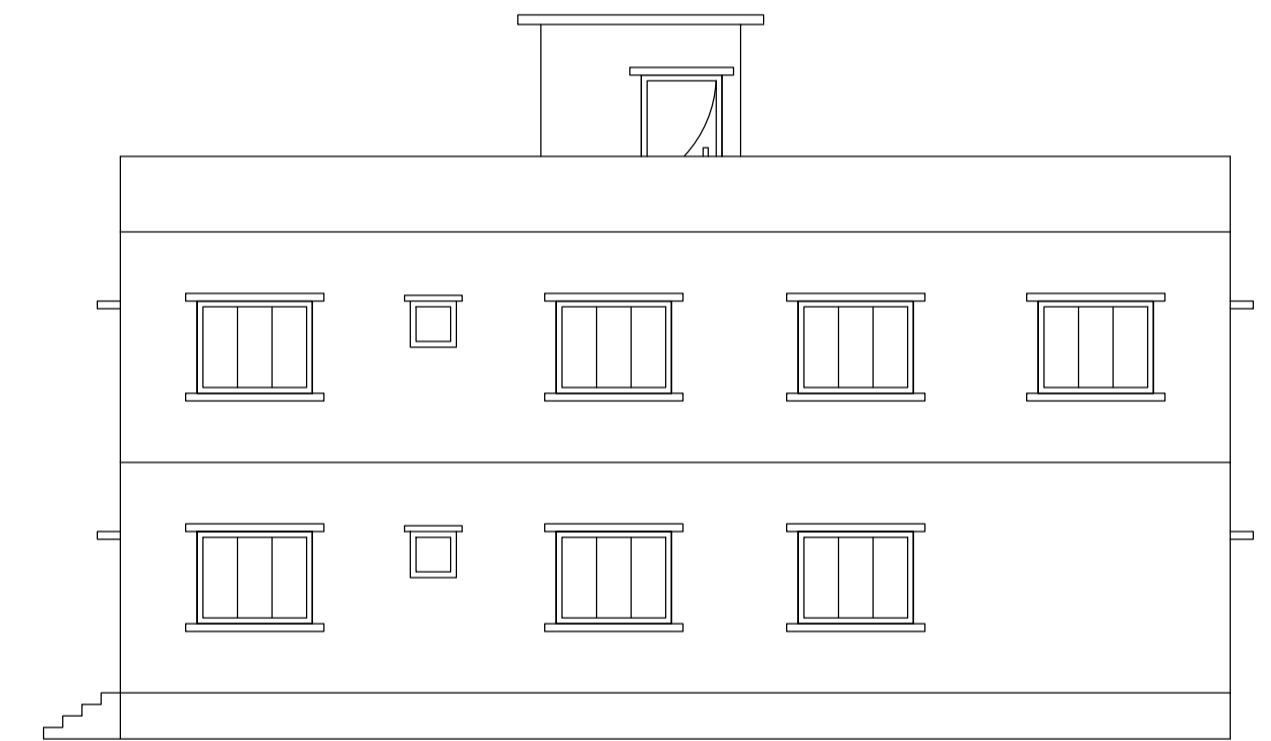

RIGHT SIDE ELEVATION (SCALE 1:100)

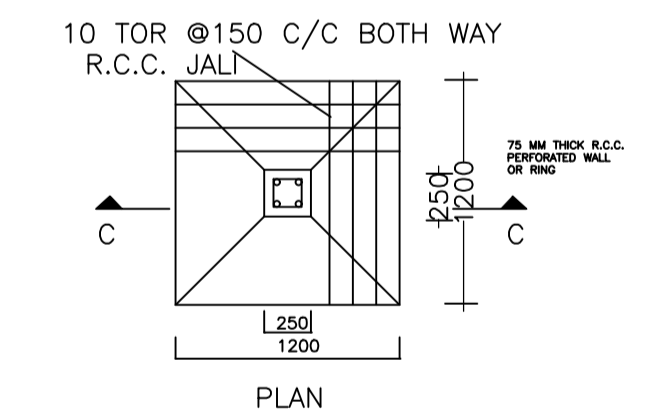

DETAIL OF FOUNDATION

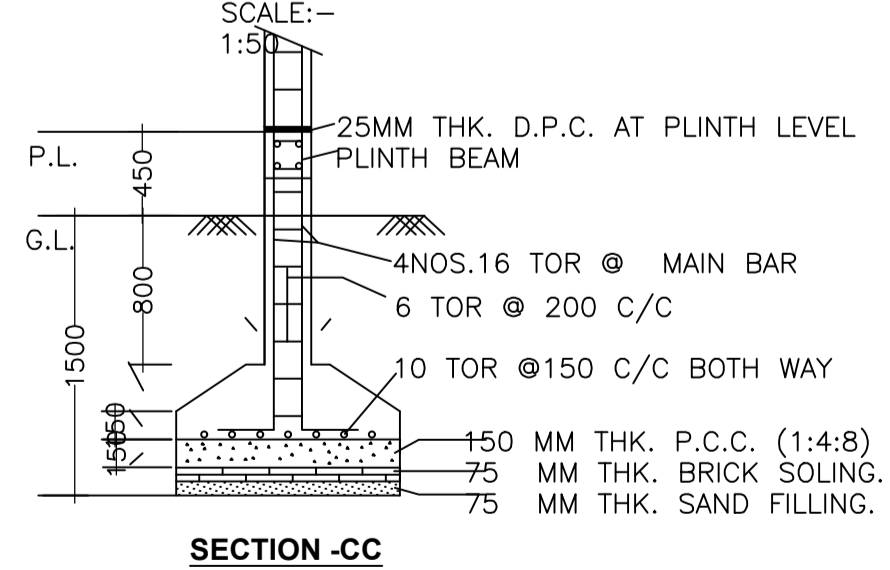

SECTION-CC

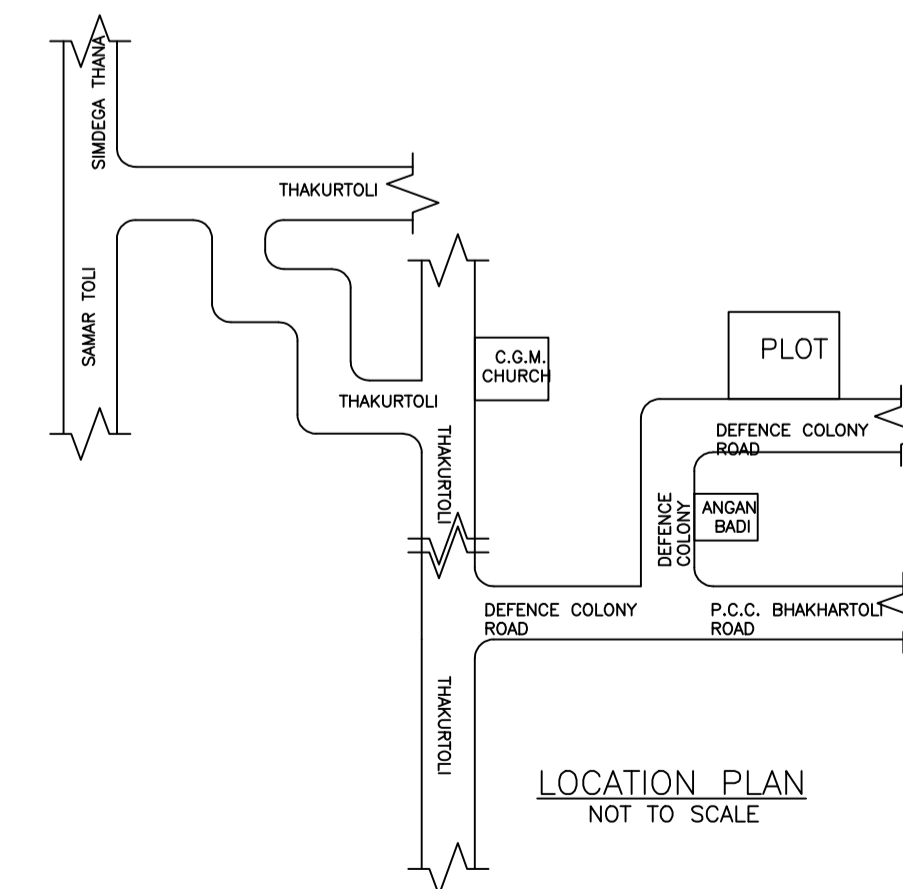

LOCATION PLAN (NOT TO SCALE)

Building :A1 (BUILDING)

Floor Name	Total Built Up Area (Sq.mt.)	Deductions (Area in Sq.mt.)	Proposed FAR Area (Sq.mt.)	Total FAR Area (Sq.mt.)	Total Consumed Additional FAR Area (Sq.mt.)	Trmt (No.)
Ground Floor	127.80	8.26	119.54	119.54	119.54	01
First Floor	127.81	9.25	118.56	118.56	118.56	01
Terrace Floor	0.00	0.00	0.00	0.00	0.00	00
Total:	255.61	17.51	238.10	238.10	238.10	02
Total Number of Same Buildings	1					
Total:	255.61	17.51	238.10	238.10	238.10	02

SCHEDULE OF DOOR:

BUILDING NAME	NAME	LENGTH	HEIGHT	NOS
A1 (BUILDING)	D2	0.76	2.10	06
A1 (BUILDING)	D1	0.91	2.10	02
A1 (BUILDING)	D	1.07	2.10	10
A1 (BUILDING)	D0	1.07	2.10	02

SCHEDULE OF WINDOW/VENTILATION:

BUILDING NAME	NAME	LENGTH	HEIGHT	NOS
A1 (BUILDING)	V	0.61	1.20	04
A1 (BUILDING)	W1	1.22	1.20	05
A1 (BUILDING)	W	1.52	1.20	18

UnitBUA Table for Building :A1 (BUILDING)

FLOOR	Name	UnitBUA Type	UnitBUA Area	Carpet Area	No. of Rooms	No. of Tenement
GROUND FLOOR PLAN	SPLIT 1	FLAT	96.33	96.06	10	1
FIRST FLOOR PLAN	SPLIT 2	FLAT	95.35	95.11	10	1
Total:	-	-	191.68	191.17	20	2

LTP NAME AND SIGNATURE	STRUCTURAL ENG'S NAME AND SIGNATURE	BUILDER NAME AND SIGNATURE
RAJESH KUMAR SINPC/DFTMN/0008/2017		