

SITE PLAN

FAR & Tenement Details (Table 4c-1)

Building	No. of Same Bldg	Total Built Up Area (Sq.mt.)	Proposed FAR Area (Sq.mt.) Resi.	Total FAR Area (Sq.mt.)	Total Consumed Additional FAR Area (Sq.mt.)	Tnmt (No.)
A (SRI THEODORE BAXLA)	1	273.29	273.29	273.29	273.29	01
Grand Total :	1	273.29	273.29	273.29	273.29	01

Proposal Basic Information

Proposal File No.	SINPC/BP/0086/W02/2018
Owner Name	THEODORE BAXLA
Khata No	170
Plot No	2541
Village Name	Gotra
Use	Residential
SubUse	Residential Bldg/Apartment

AREA STATEMENT SIMDEGA NAGAR PANCHAYAT	VERSION NO: 1.0.30	VERSION DATE: 30/06/2018
PROJECT DETAIL:		
Region: JHARKHAND URBAN LOCAL BODIES	Plot Use: Residential	
District: SIMDEGA	Plot SubUse: Residential Bldg/Apartment	
Authority: SIMDEGA NAGAR PANCHAYAT	PlotNearbyReligiousStructure: NA	
Inward No: SINPC/BP/0086/W02/2018	PlotSubPlot No: 2541	
Application Type: General Proposal	North: -	
Project Type: Building Permission	South: -	
Nature of Development Area: New Area	East: -	
Location	West: -	
AREA DETAILS:		
AREA OF PLOT (Minimum)	(A)	785.70
Deduction for NetPlot Area		
Surrender Free of Cost		32.40
Total		32.40
NET AREA OF PLOT(Gross Plot Area - Deduction from Gross Plot area)	(A-Deductions)	753.30
Deduction for Balance Plot Area(from Gross Plot Area)		
Surrender Free of Cost		32.40
Common Plot		82.06
Total		114.46
BALANCE AREA OF PLOT(Net Plot Area - Recreational/Amenity space)	(A-Deductions)	671.24
PLOT AREA FOR COVERAGE(Net Plot Area)	(A-Deductions)	753.30
Plot Area for FAR (Net Plot Area + RoadWidening Area)	(A-Deductions)	785.70
COVERAGE CHECK		
Permissible Coverage area (60.00 %)		451.98
Proposed Coverage Area (19.07 %)		143.62
Total Prop. Coverage Area (19.07 %)		143.62
Balance coverage area (40.93 %)		308.36
FAR CHECK		
Perm. FAR Area (1.50)		1178.55
Total Perm. FAR area		1178.55
Residential FAR		273.29
Proposed FAR Area		273.29
Total Proposed FAR Area		273.29
Consumed FAR (Factor)		0.35
Balance FAR Area		905.26
BUILT UP AREA CHECK		
Total Proposed BuiltUp Area		273.29
ARCHITECT (Regd)		MD RAGIB SAYEED
ENGINEER (Regd)		
SUPERVISOR (Regd)		
OWNER (Regd)		THEODORE BAXLA
DEVELOPMENT AUTHORITY		LOCAL BODY

COLOR INDEX	
PLOT BOUNDARY	Black
ABUTTING ROAD	Green
PROPOSED CONSTRUCTION	Red
COMMON PLOT	Yellow
ROAD WIDENING AREA	Blue
EXISTING (To be retained)	Orange
EXISTING (To be demolished)	Light Blue

Buildingwise Floor FAR Details

Floor Name	Building Name		Total	
	Proposed Built Up Area (Sq.mt.)	Proposed FAR Area (Sq.mt.)	Total Proposed Built Up Area (Sq.mt.)	Total FAR Area (Sq.mt.)
Ground Floor	143.62	143.62	143.62	143.62
First Floor	129.67	129.67	129.67	129.67
Terrace Floor	0.00	0.00	0.00	0.00
Total	273.29	273.29	273.29	273.29

Building USE/SUBUSE Details

Building Name	Building Use	Building SubUse	Building Structure
A (SRI THEODORE BAXLA)	Residential	Residential Bldg/Apartment	Non-Highrise

LTP NAME AND SIGNATURE	STRUCTURAL ENG'S NAME AND SIGNATURE	BUILDER NAME AND SIGNATURE	DIGITAL SIGNATURE
MD RAGIB SAYEED SINPC/ENG/0001/2017			

Proposal Basic Information

Proposal File No.	SINPC/BP/0086/W02/2018
Owner Name	THEODORE BAXLA
Khata No	170
Plot No	2541
Village Name	Gotra
Use	Residential
SubUse	Residential Bldg/Apartment

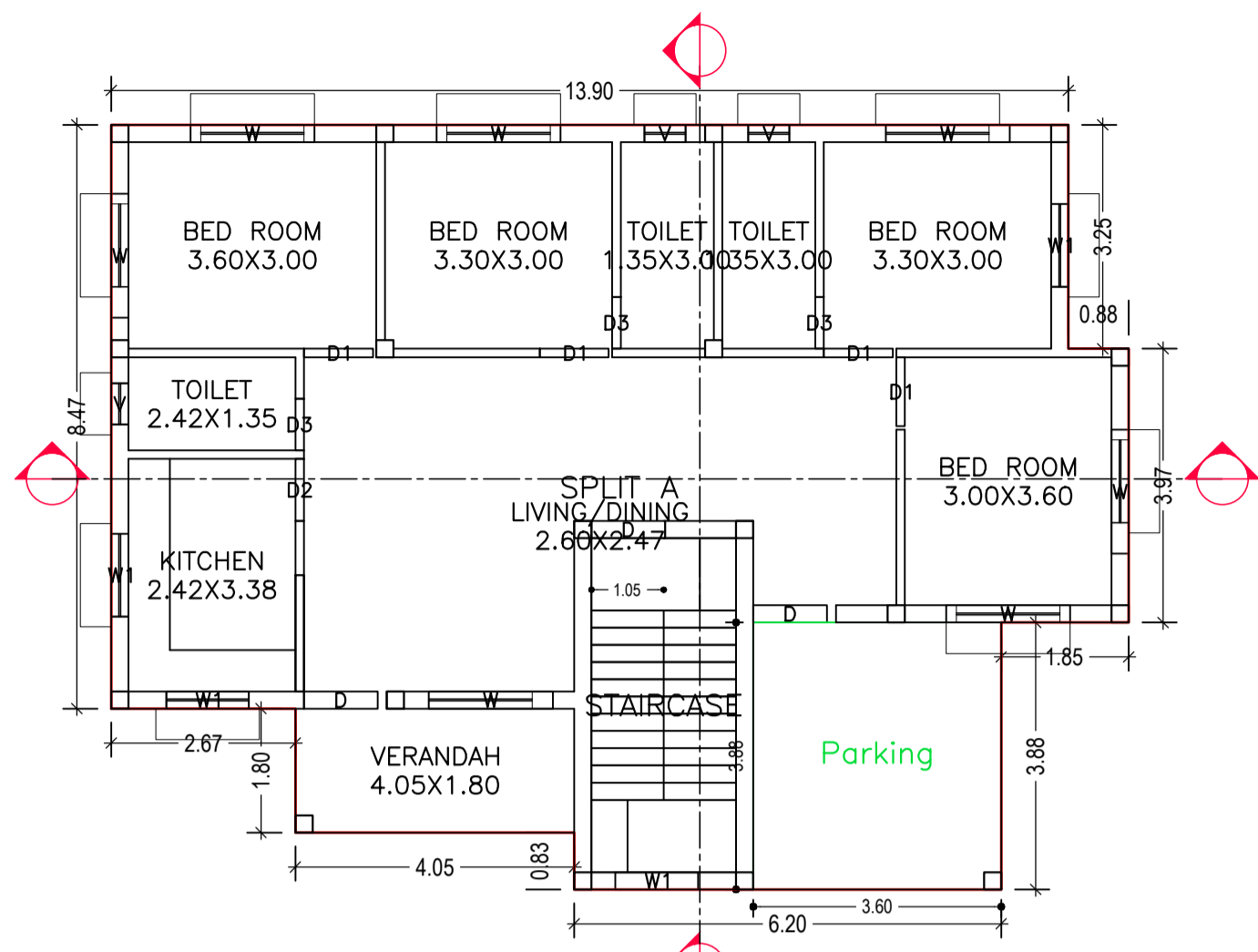

GROUND FLOOR PLAN (Proposed) (SCALE 1:100)

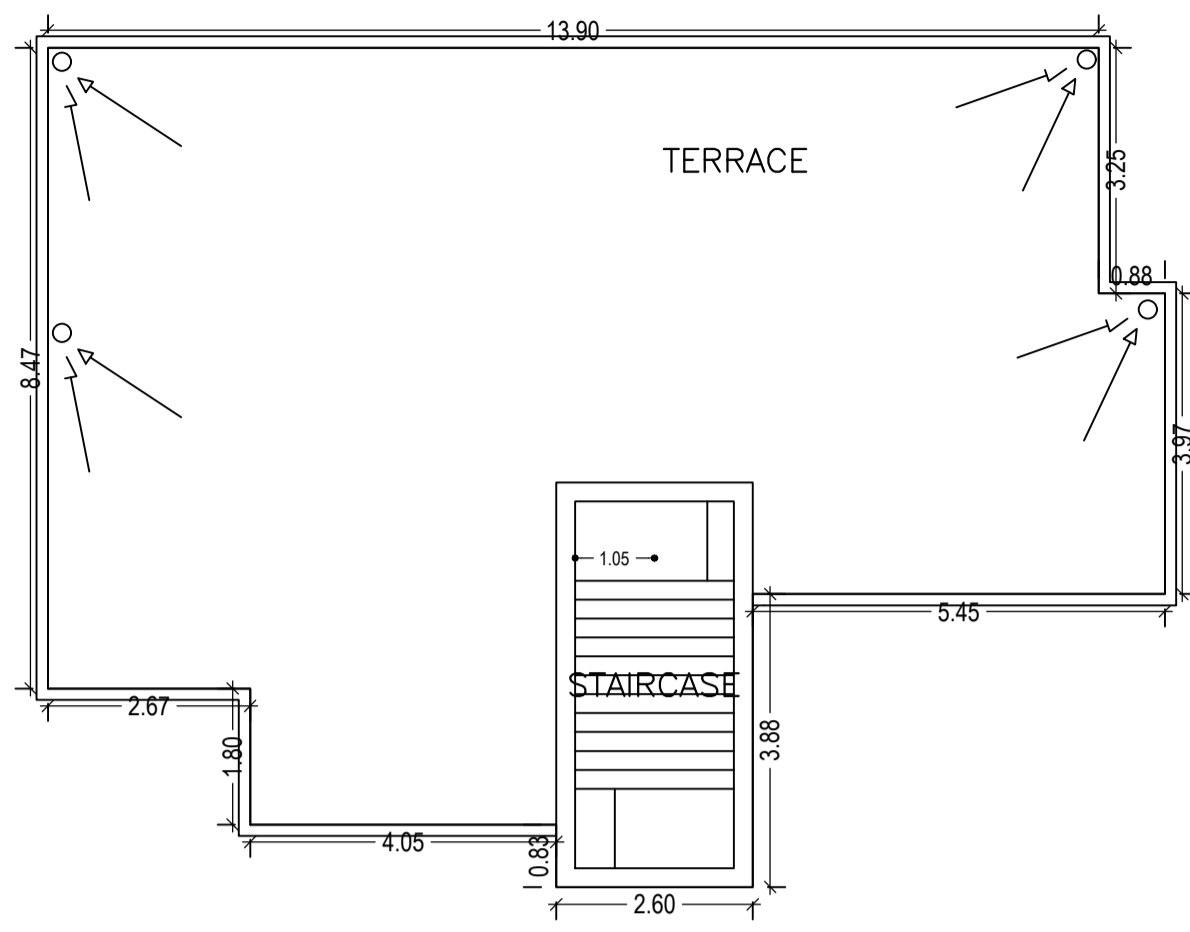

TERRACE FLOOR PLAN (SCALE 1:100)

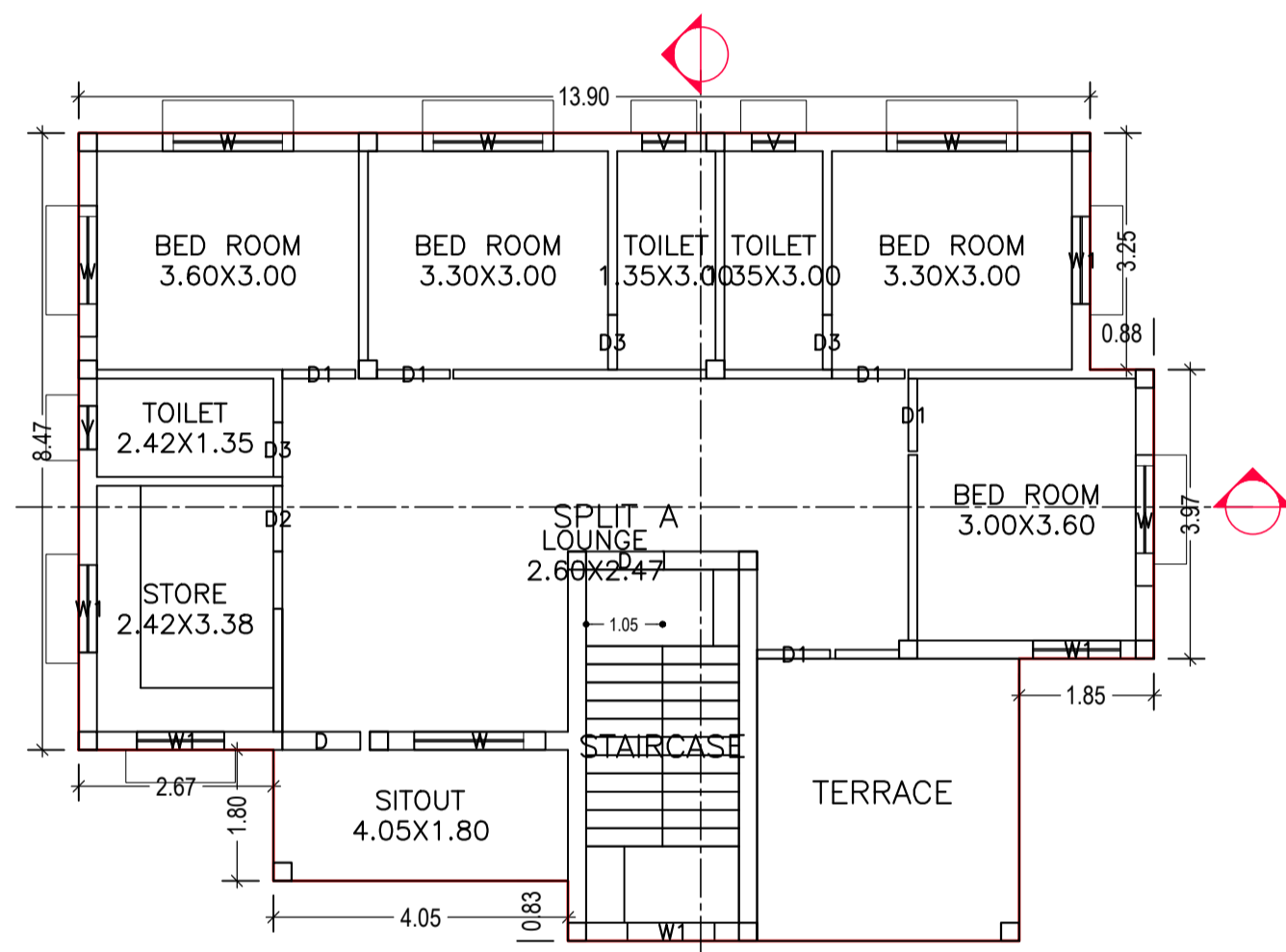

FIRST FLOOR PLAN (Proposed) (SCALE 1:100)

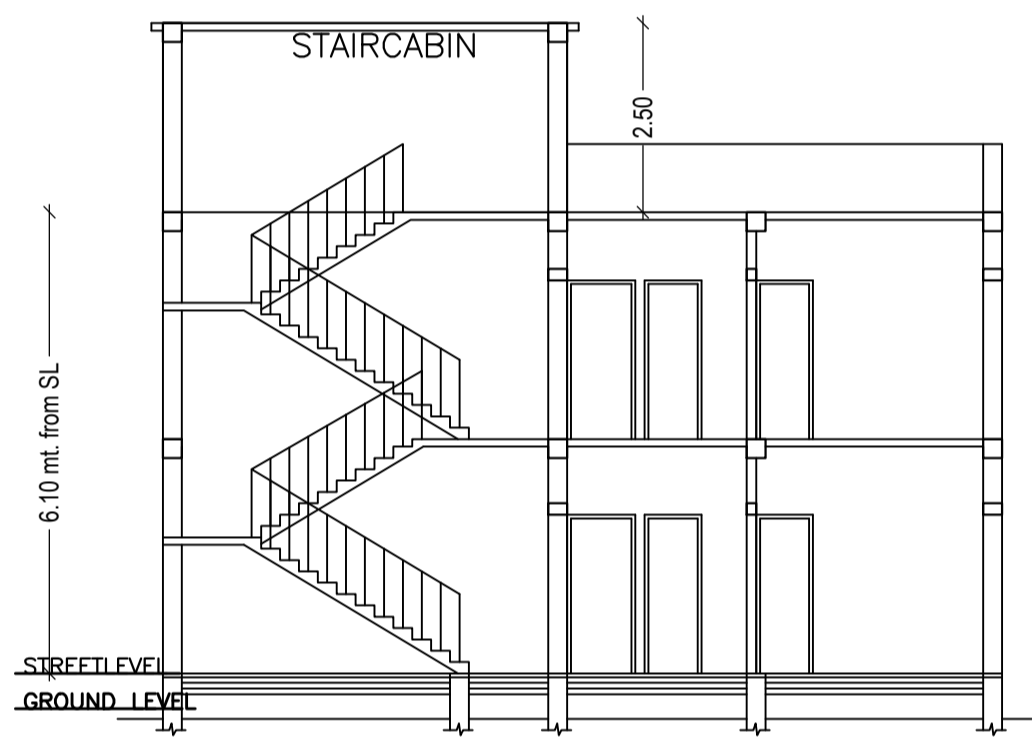

SECTION Y-Y 1:100

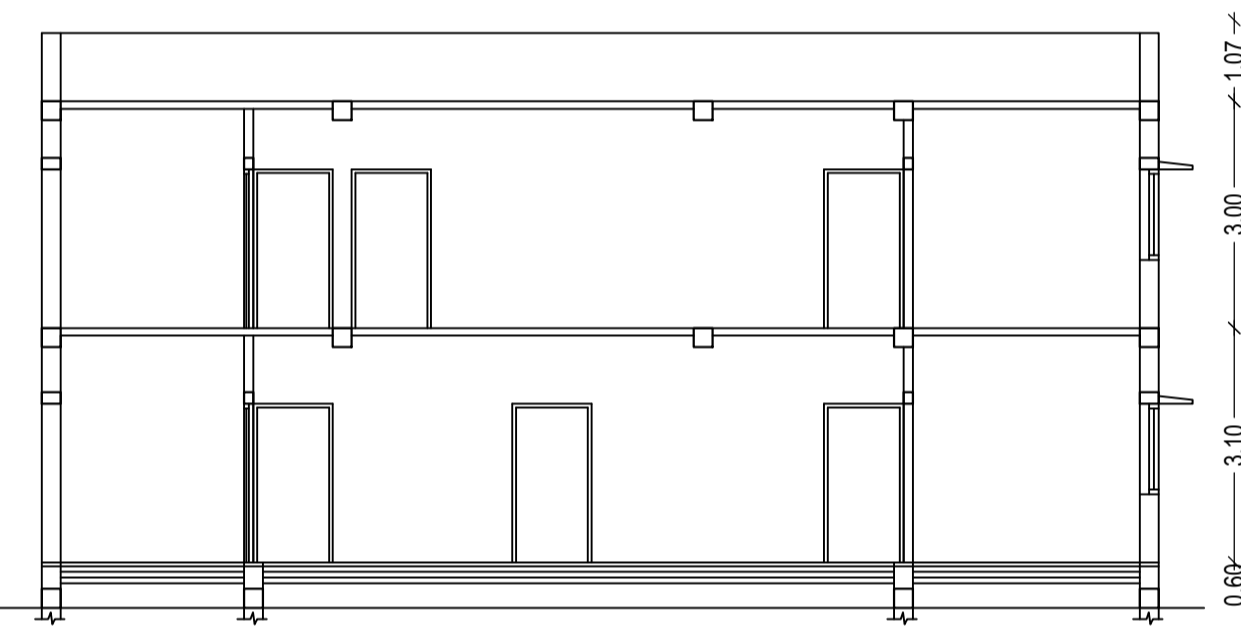

SECTION X-X 1:100

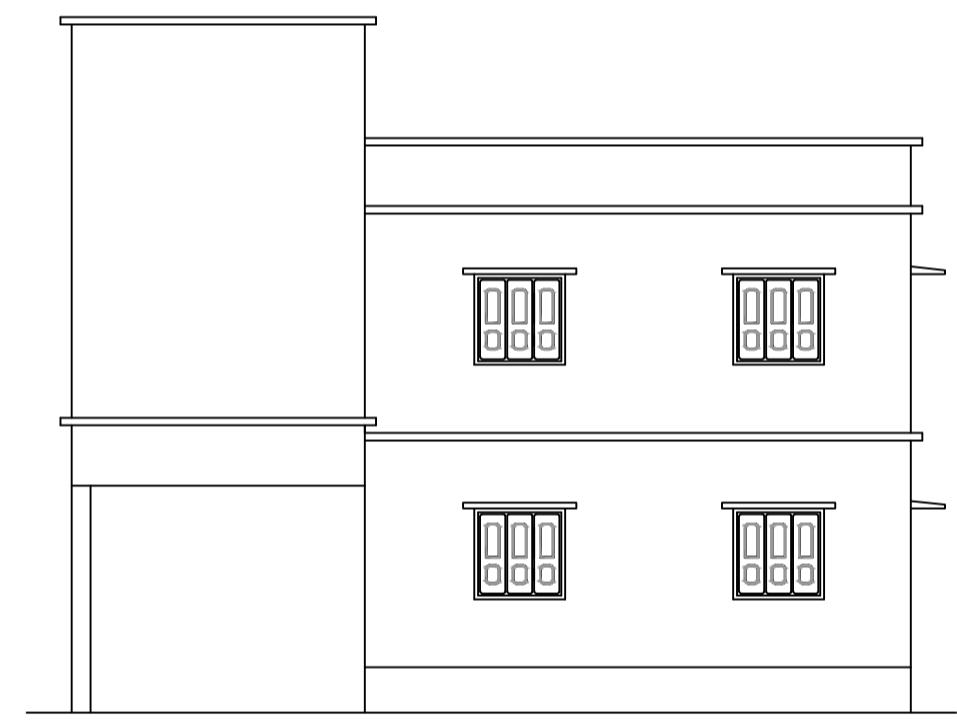

FRONT ELEVATION 1:100

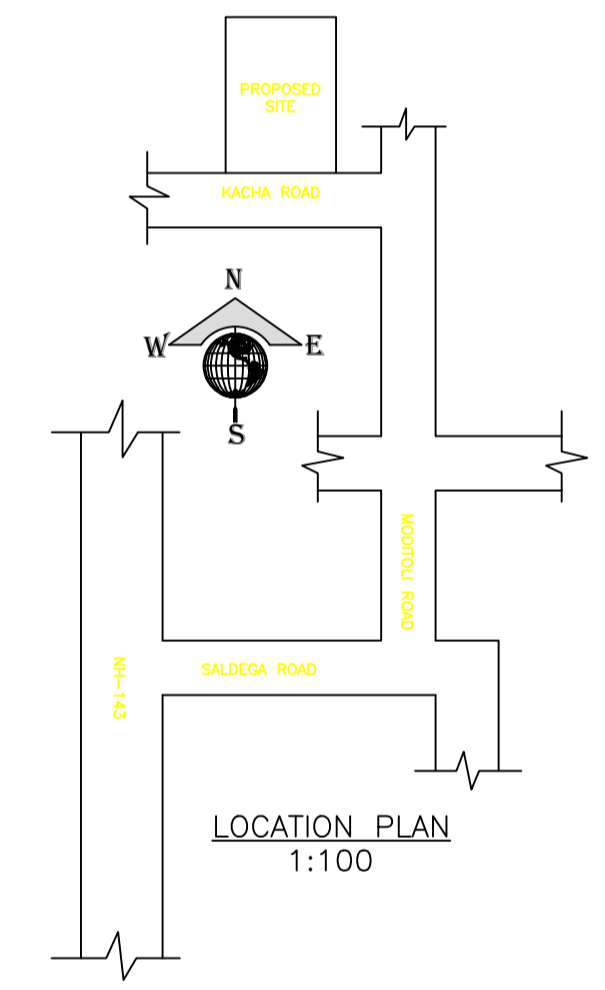

LOCATION PLAN 1:100



SIDE ELEVATION 1:100

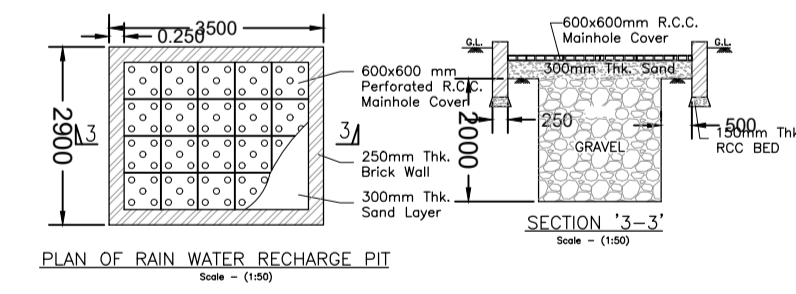

PLAN OF RAIN WATER RECHARGE PIT

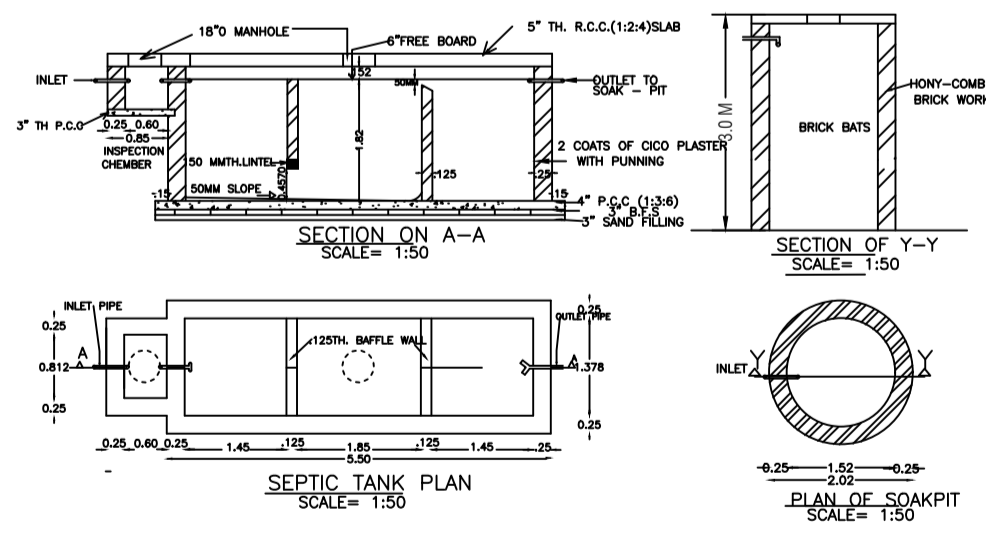

SEPTIC TANK PLAN

SECTION A-A

SCHEDULE OF DOOR:

BUILDING NAME	NAME	LENGTH	HEIGHT	NOS
A (SRI THEODORE BAXLA)	D3	0.75	2.13	06
A (SRI THEODORE BAXLA)	D2	0.90	2.13	02
A (SRI THEODORE BAXLA)	D1	1.00	2.13	09
A (SRI THEODORE BAXLA)	D	1.07	2.13	05

SCHEDULE OF WINDOW/VENTILATION:

BUILDING NAME	NAME	LENGTH	HEIGHT	NOS
A (SRI THEODORE BAXLA)	V	0.60	1.20	06
A (SRI THEODORE BAXLA)	W1	1.20	2.70	09
A (SRI THEODORE BAXLA)	W	1.80	2.70	13

UnitBUA Table for Building :A (SRI THEODORE BAXLA)

FLOOR	Name	UnitBUA Type	UnitBUA Area	Carpet Area	No. of Rooms	No. of Tenement
GROUND FLOOR PLAN	SPLIT A	FLAT	213.20	212.78	10	1
FIRST FLOOR PLAN	SPLIT A	FLAT	0.00	0.00	10	0
Total:	-	-	213.20	212.78	20	1

Building :A (SRI THEODORE BAXLA)

Floor Name	Total Built Up Area (Sq.mt.)	Proposed FAR Area (Sq.mt.)	Total FAR Area (Sq.mt.)	Total Consumed Additional FAR Area (Sq.mt.)	Tnmt (No.)
Ground Floor	143.62	143.62	143.62	143.62	01
First Floor	129.67	129.67	129.67	129.67	00
Terrace Floor	0.00	0.00	0.00	0.00	00
Total:	273.29	273.29	273.29	273.29	01
Total Number of Same Buildings	1				
Total:	273.29	273.29	273.29	273.29	01

LTP NAME AND SIGNATURE	STRUCTURAL ENG'S NAME AND SIGNATURE	BUILDER NAME AND SIGNATURE	DIGITAL SIGNATURE
MD RAGIB SAYEED SINPC/ENG/0001/2017			