

FAR & Tenement Details (Table 4c-1)

Building	No. of Same Bldg	Total Built Up Area (Sq.mt.)	Proposed FAR Area (Sq.mt.) Resi.	Total FAR Area (Sq.mt.)	Total Consumed Additional FAR Area (Sq.mt.)	Tnmt (No.)
R (BUILDING)	1	104.52	104.52	104.52	104.52	01
Grand Total :	1	104.52	104.52	104.52	104.52	01

Proposal Basic Information

Proposal File No.	SINPC/BB/0131/W/17/2019
Owner Name	ADAM KHAN
Khata No	83
Plot No	942
Village Name	Simdega
Use	Residential
SubUse	Bungalow/ Dwelling / Non Apartment

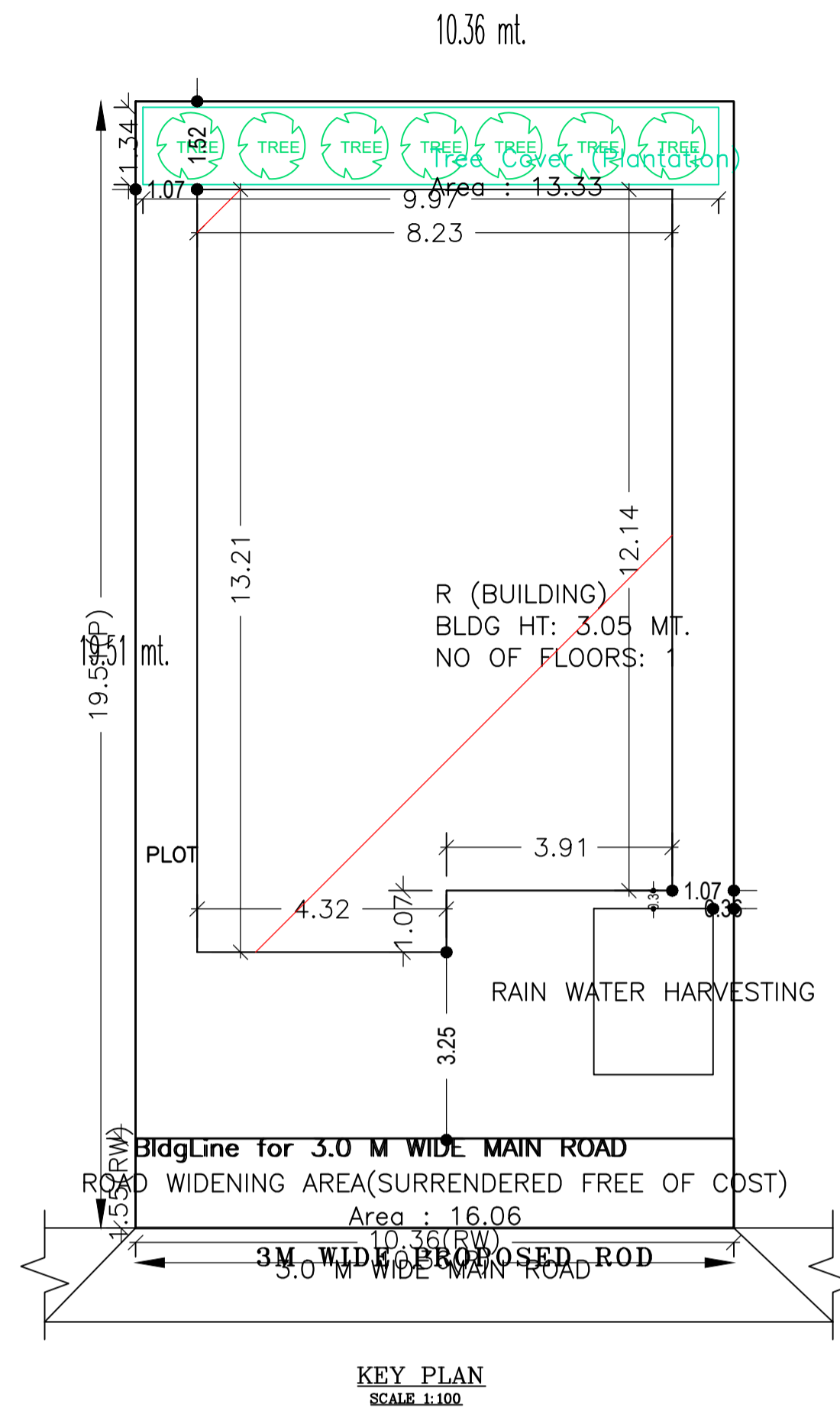

AREA STATEMENT SIMDEGA NAGAR PANCHAYAT	VERSION NO. : 1.0.30
PROJECT DETAIL:	VERSION DATE: 29/04/2019
Region: JHARKHAND URBAN LOCAL BODIES	Plot Use: Residential
District: SIMDEGA	Plot SubUse: Bungalow/ Dwelling / Non Apartment
Authority: SIMDEGA NAGAR PANCHAYAT	PlotNearbyReligiousStructure: NA
Inward No: SINPC/BB/0131/W/17/2019	PlotSubPlot No: 942
Application Type: General Proposal	North: -
Project Type: Building Permission	South: -
Nature of Development: New	East: -
Location of Development Area: Old Area	West: -
AREA DETAILS:	SQ.MT.
AREA OF PLOT (Minimum)	(A) 202.16
Deduction for NetPlot Area	
Surrender Free of Cost	16.06
Total	16.06
NET AREA OF PLOT(Gross Plot Area - Deduction from Gross Plot area)	(A-Deductions) 186.09
Deduction for Balance Plot Area(from Gross Plot Area)	
Surrender Free of Cost	16.06
Common Plot	13.33
Total	29.40
BALANCE AREA OF PLOT(Net Plot Area - Recreational/Amenity space)	(A-Deductions) 172.76
PLOT AREA FOR COVERAGE(Net Plot Area)	(A-Deductions) 186.09
Plot Area for FAR (Net Plot Area + Road Widening Area)	(A-Deductions) 202.16
COVERAGE CHECK	
Permissible Coverage area (70.00 %)	130.26
Proposed Coverage Area (56.17 %)	104.52
Total Prop. Coverage Area (56.17 %)	104.52
Balance coverage area (13.83 %)	25.74
FAR CHECK	
Perm. FAR Area (1.20)	242.59
Total Perm. FAR area	242.59
Residential FAR	104.52
Proposed FAR Area	104.52
Total Proposed FAR Area	104.52
Consumed FAR (Factor)	0.52
Balance FAR Area	138.07
BUILT UP AREA CHECK	
Total Proposed BuiltUp Area	104.52
ARCHITECT (Regd)	RAJESH KUMAR
ENGINEER (Regd)	
SUPERVISOR (Regd)	
OWNER (Regd)	ADAM KHAN
DEVELOPMENT AUTHORITY	LOCAL BODY

SITE PLAN

COLOR INDEX

PLOT BOUNDARY	Black
ABUTTING ROAD	Green
PROPOSED CONSTRUCTION	Red
COMMON PLOT	Yellow
ROAD WIDENING AREA	Blue
EXISTING (To be retained)	Blue
EXISTING (To be demolished)	Yellow

Buildingwise Floor FAR Details

Floor Name	Building Name R (BUILDING)		Total	
	Proposed Built Up Area (Sq.mt.)	Proposed FAR Area (Sq.mt.)	Total Proposed Built Up Area (Sq.mt.)	Total FAR Area (Sq.mt.)
Ground Floor	104.52	104.52	104.52	104.52
Terrace Floor	0.00	0.00	0.00	0.00
Total	104.52	104.52	104.52	104.52

Building USE/SUBUSE Details

Building Name	Building Use	Building SubUse	Building Structure
R (BUILDING)	Residential	Bungalow/ Dwelling / Non Apartment	Non-Highrise

LTP NAME AND SIGNATURE	STRUCTURAL ENG'S NAME AND SIGNATURE	BUILDER NAME AND SIGNATURE	DIGITAL SIGNATURE
RAJESH KUMAR SINPC/DFTMN/0006/2017			

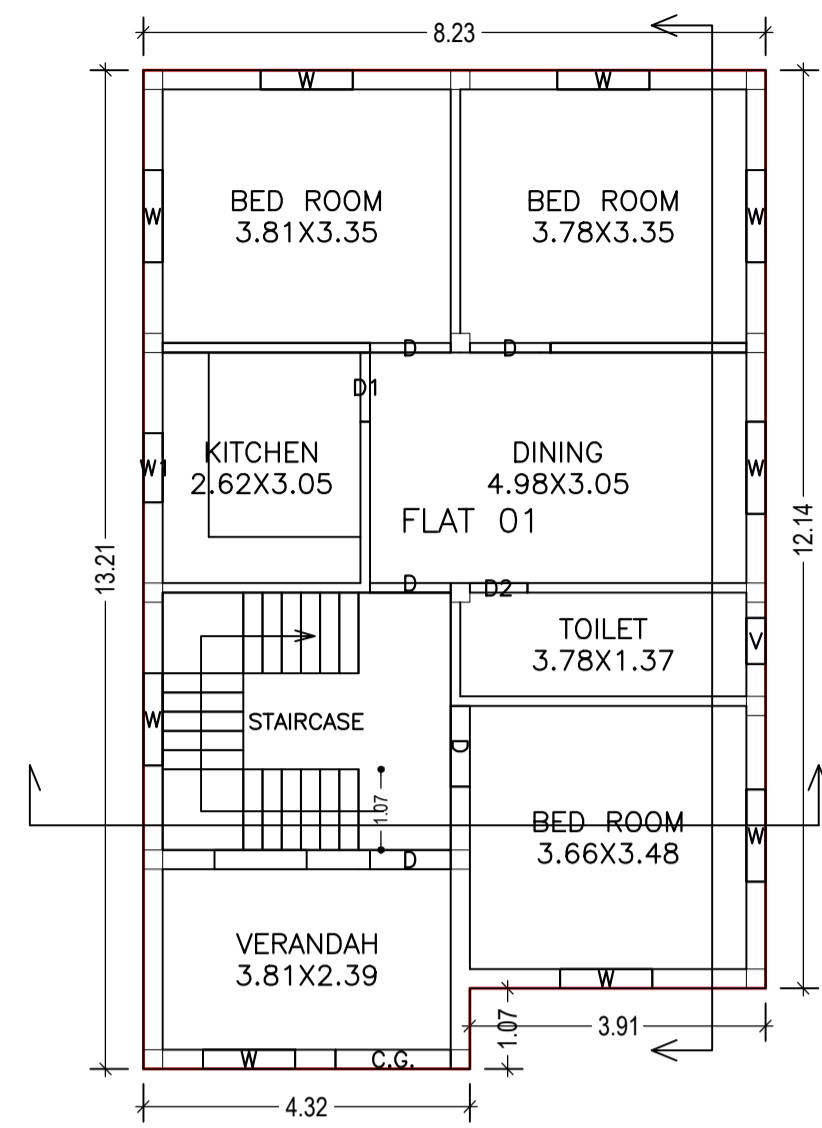

GROUND FLOOR PLAN (Proposed) SCALE 1:100

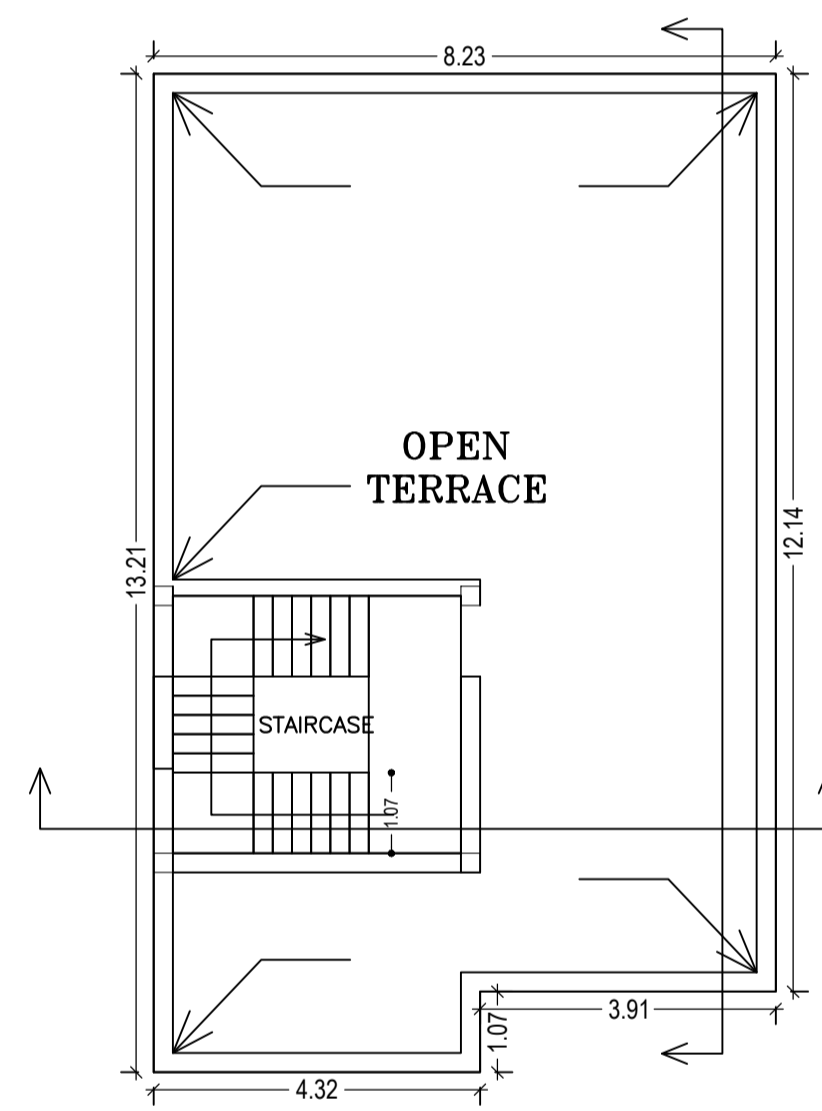

TERRACE FLOOR PLAN (SCALE 1:100)

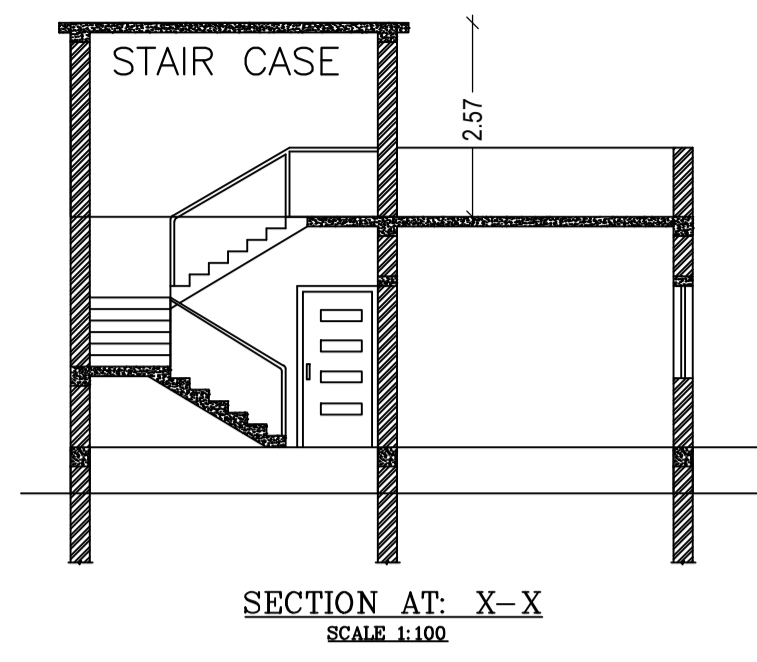

SECTION AT X-X SCALE 1:100

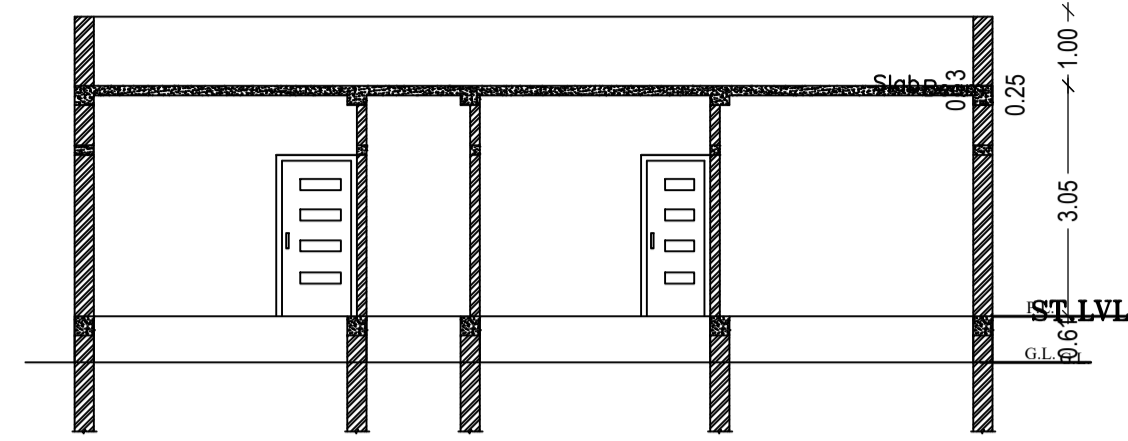

SECTION AT Y-Y SCALE 1:100

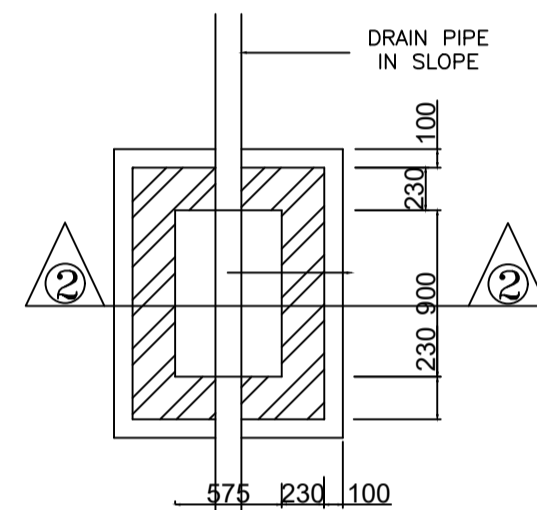

PLAN I.C.DETAILS R.C.C. COVER

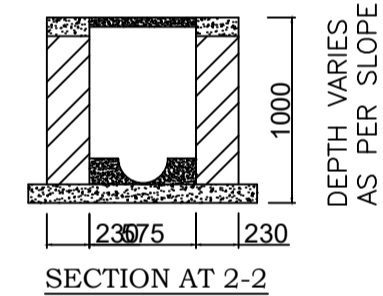

SECTION AT 2-2

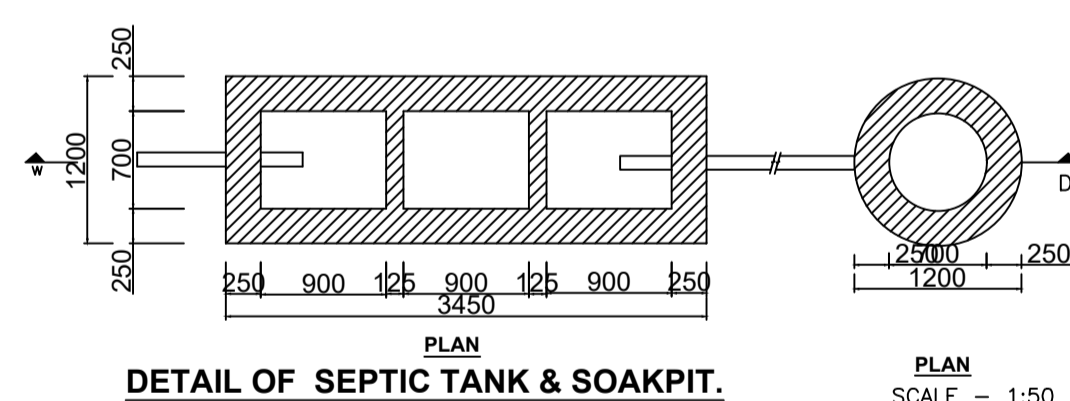

DETAIL OF SEPTIC TANK & SOAKPIT. PLAN SCALE - 1:50

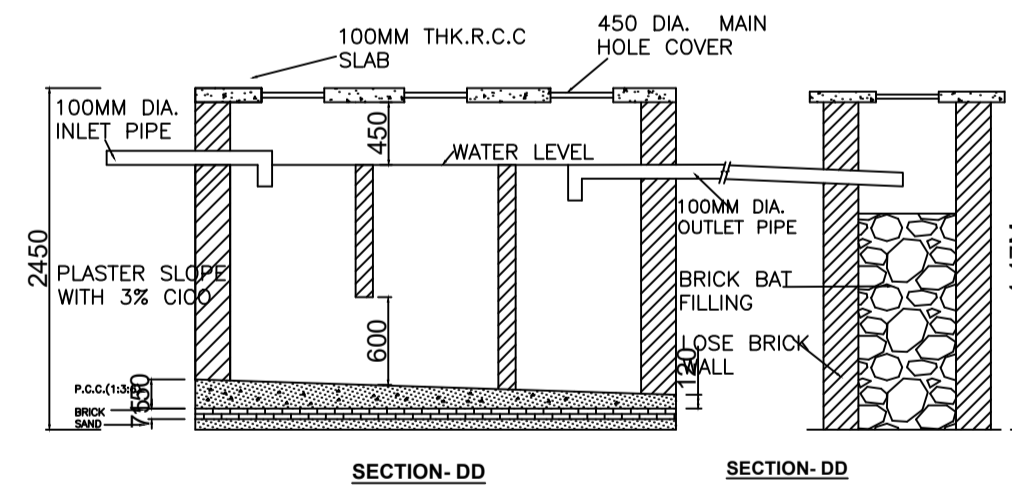

SECTION-DD

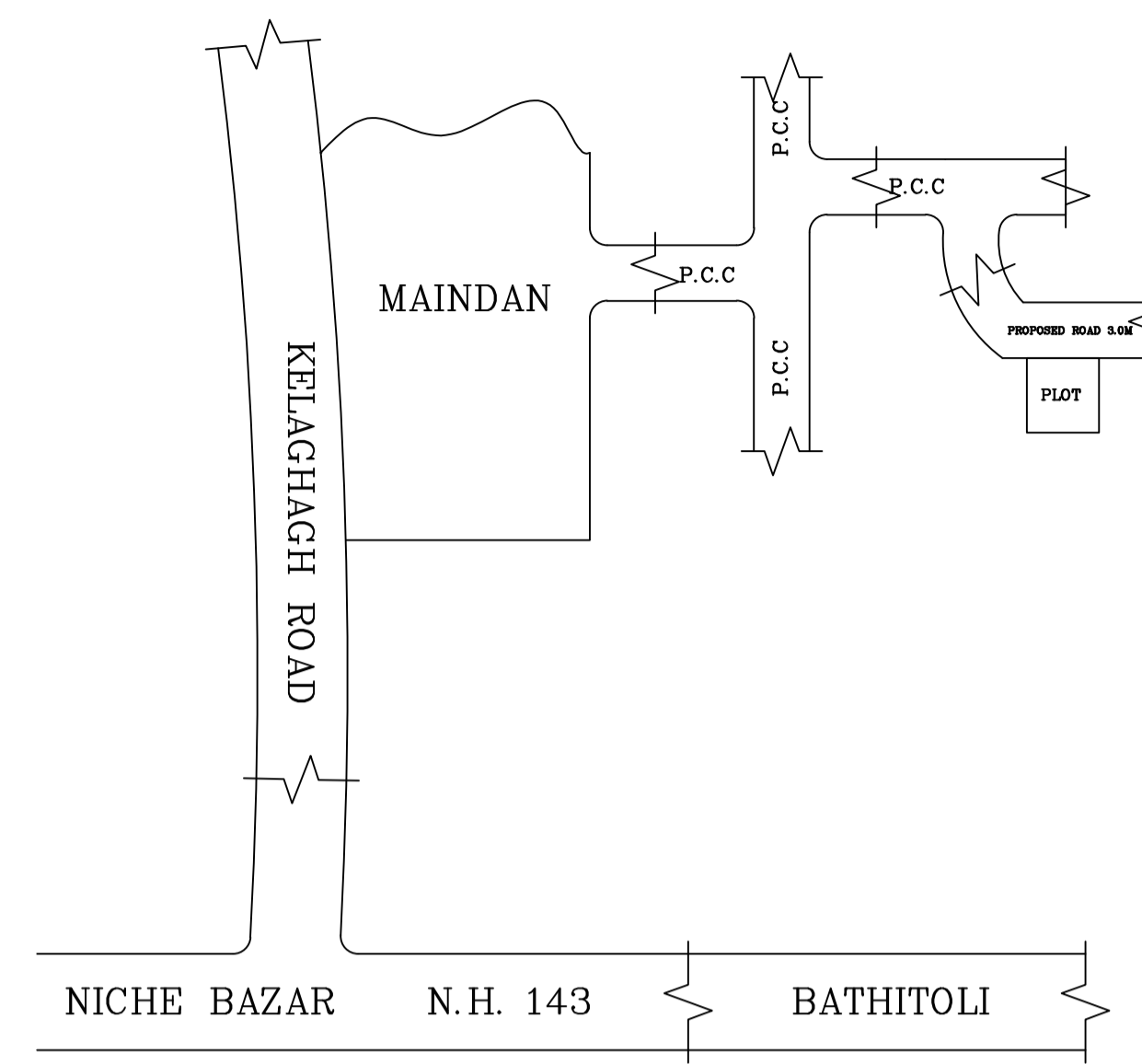

KEY PLAN SCALE 1:100

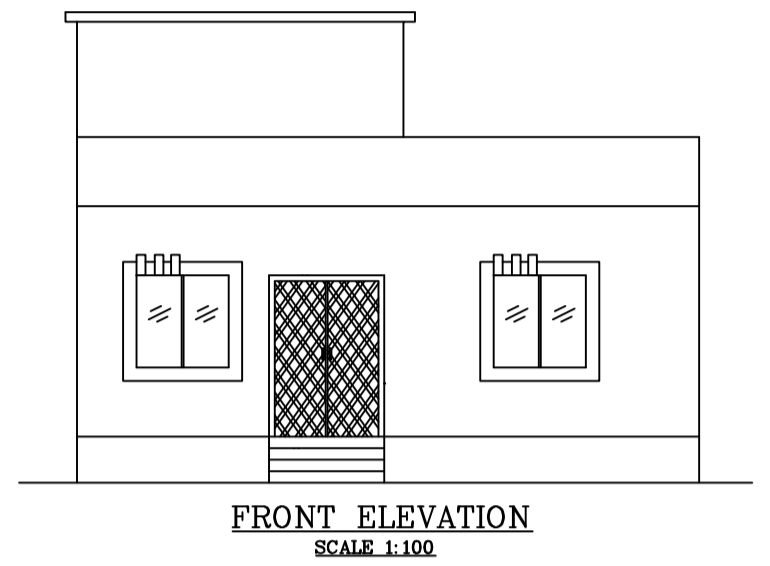

FRONT ELEVATION SCALE 1:100

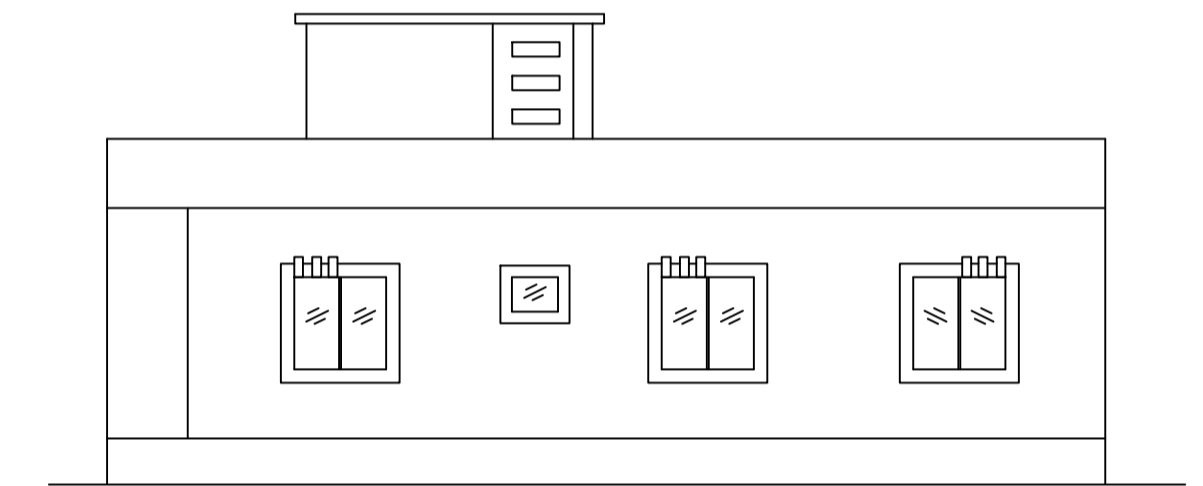

RIGHT SIDE ELEVATION SCALE 1:100

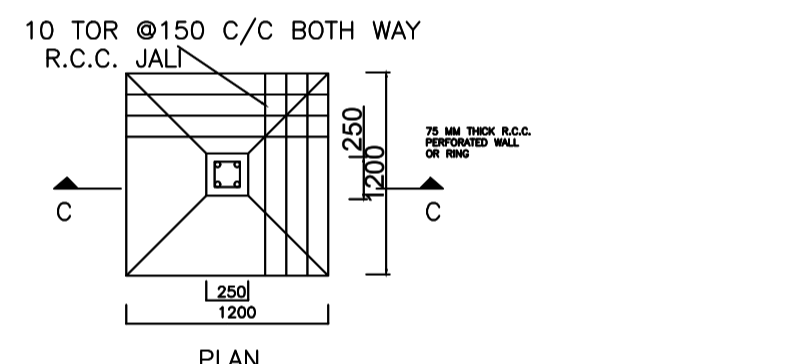

DETAIL OF FOUNDATION SCALE:- 1:50

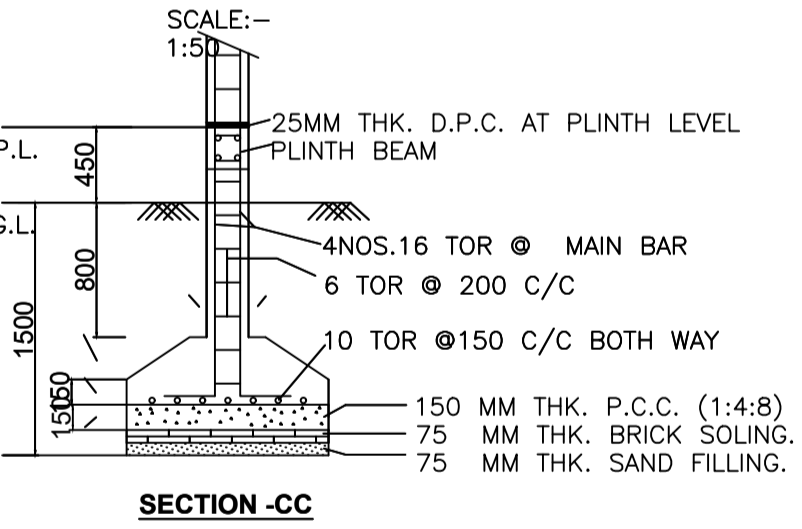

SECTION-CC

Building :R (BUILDING)

Floor Name	Total Built Up Area (Sq.mt.)	Proposed FAR Area (Sq.mt.) Resi.	Total FAR Area (Sq.mt.)	Total Consumed Additional FAR Area (Sq.mt.)	Tnmt (No.)
Ground Floor	104.52		104.52		01
Terrace Floor	0.00	0.00		0.00	00
Total:	104.52		104.52	104.52	
Total Number of Same Buildings	1				
Total:	104.52		104.52	104.52	01

SCHEDULE OF DOOR:

BUILDING NAME	NAME	LENGTH	HEIGHT	NOS
R (BUILDING)	D2	0.76	2.10	01
R (BUILDING)	D1	0.91	2.10	01
R (BUILDING)	D	1.07	2.10	05
R (BUILDING)	C.G.	1.52	2.10	01

SCHEDULE OF WINDOW/VENTILATION:

BUILDING NAME	NAME	LENGTH	HEIGHT	NOS
R (BUILDING)	V	0.61	0.61	01
R (BUILDING)	W1	0.91	1.20	01
R (BUILDING)	W	1.22	1.20	09

UnitBUA Table for Building :R (BUILDING)

FLOOR	Name	UnitBUA Type	UnitBUA Area	Carpet Area	No. of Rooms	No. of Tenement
GROUND FLOOR PLAN	FLAT 01	FLAT	80.92	80.25	7	1
Total:	-	-	80.92	80.25	7	1

LTP NAME AND SIGNATURE	STRUCTURAL ENG'S NAME AND SIGNATURE	BUILDER NAME AND SIGNATURE	DIGITAL SIGNATURE
RAJESH KUMAR SINPC/DFTMN/0006/2017			

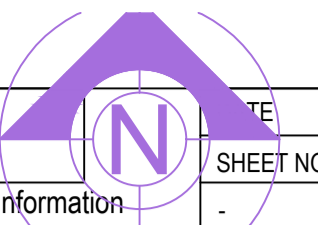

Proposal Basic Information	
Proposal File No.	SINPC/BB/0131/W17/2019
Owner Name	ADAM KHAN
Khata No	83
Plot No	942
Village Name	Simdega
Use	Residential
SubUse	Bungalow/ Dwelling / Non Apartment

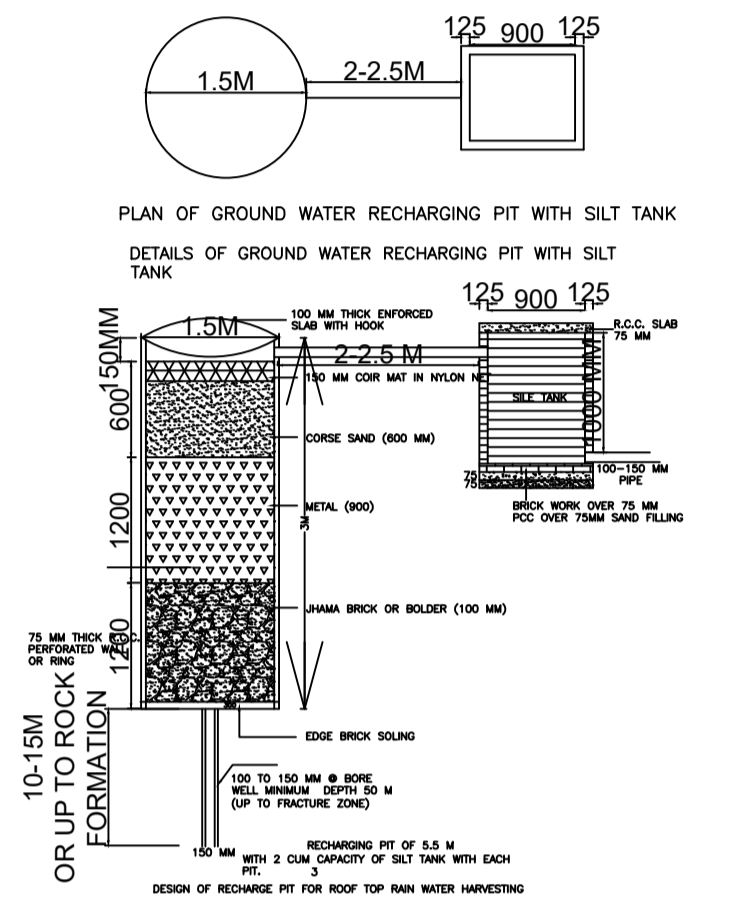

LTP NAME AND SIGNATURE	STRUCTURAL ENG'S NAME AND SIGNATURE	BUILDER NAME AND SIGNATURE	DIGITAL SIGNATURE
RAJESH KUMAR SINPC/DFTMN/0006/2017			