

SITE PLAN

FAR & Tenement Details (Table 4c-1)

Building	No. of Same Bldg	Total Built Up Area (Sq.mt.)	Proposed FAR Area (Sq.mt.) Resi.	Total FAR Area (Sq.mt.)	Total Consumed Additional FAR Area (Sq.mt.)	Tnmt (No.)
A (AQUIB AHMAD)	1	228.36	228.36	228.36	228.36	01
Grand Total :	1	228.36	228.36	228.36	228.36	01

Proposal Basic Information	
Proposal File No.	SINPC/BP/0111/W/18/2019
Owner Name	MD AQUIB AHMAD
Khata No	19
Plot No	1070/1071
Village Name	Simdega
Use	Residential
SubUse	Residential Bldg/Apartment

AREA STATEMENT SIMDEGA NAGAR PANCHAYAT		VERSION NO. : 1.0.35
PROJECT DETAIL:		VERSION DATE: 13/03/2019
Region: JHARKHAND URBAN LOCAL BODIES	Plot Use: Residential	
District: SIMDEGA	Plot SubUse: Residential Bldg/Apartment	
Authority: SIMDEGA NAGAR PANCHAYAT	PlotNearbyReligiousStructure: NA	
Inward No: SINPC/BP/0111/W/18/2019	PlotSubPlot No: 1070/1071	
Application Type: General Proposal	North: -	
Project Type: Building Permission	South: -	
Nature of Development: New	East: -	
Location of Development Area: Old Area	West: -	
AREA DETAILS:		
AREA OF PLOT (Minimum)	(A)	SQ.MT. 196.09
Deduction for NetPlot Area		
Surrender Free of Cost		7.47
Total		7.47
NET AREA OF PLOT(Gross Plot Area - Deduction from Gross Plot area)	(A-Deductions)	188.62
Deduction for Balance Plot Area(from Gross Plot Area)		
Surrender Free of Cost		7.47
Common Plot		20.23
Total		27.70
BALANCE AREA OF PLOT(Net Plot Area - Recreational/Amenity space)	(A-Deductions)	168.39
PLOT AREA FOR COVERAGE(Net Plot Area)	(A-Deductions)	188.62
Plot Area for FAR (Net Plot Area + RoadWidening Area)	(A-Deductions)	196.09
COVERAGE CHECK		
Permissible Coverage area (70.00 %)		132.03
Proposed Coverage Area (62.96 %)		118.75
Total Prop. Coverage Area (62.96 %)		118.75
Balance coverage area (7.04 %)		13.28
FAR CHECK		
Perm. FAR Area (1.50)		294.14
Total Perm. FAR area		294.14
Residential FAR		228.36
Proposed FAR Area		228.36
Total Proposed FAR Area		228.36
Consumed FAR (Factor)		1.16
Balance FAR Area		65.78
BUILT UP AREA CHECK		
Total Proposed BuiltUp Area		228.36
ARCHITECT (Regd)	MD RAGIB SAYEED	
ENGINEER (Regd)		
SUPERVISOR (Regd)		
OWNER (Regd)	MD AQUIB AHMAD	
DEVELOPMENT AUTHORITY		LOCAL BODY

COLOR INDEX	
PLOT BOUNDARY	Black
ABUTTING ROAD	Green
PROPOSED CONSTRUCTION	Red
COMMON PLOT	Yellow
ROAD WIDENING AREA	Orange
EXISTING (To be retained)	Blue
EXISTING (To be demolished)	Light Blue

Buildingwise Floor FAR Details

Floor Name	Building Name A (AQUIB AHMAD)		Total	
	Proposed Built Up Area (Sq.mt.)	Proposed FAR Area (Sq.mt.)	Total Proposed Built Up Area (Sq.mt.)	Total FAR Area (Sq.mt.)
Ground Floor	118.75	118.75	118.75	118.75
First Floor	109.61	109.61	109.61	109.61
Terrace Floor	0.00	0.00	0.00	0.00
Total	228.36	228.36	228.36	228.36

Building USE/SUBUSE Details

Building Name	Building Use	Building SubUse	Building Structure
A (AQUIB AHMAD)	Residential	Bungalow/ Dwelling / Non Apartment	Non-Highrise

LTP NAME AND SIGNATURE	STRUCTURAL ENG'S NAME AND SIGNATURE	BUILDER NAME AND SIGNATURE	DIGITAL SIGNATURE
MD RAGIB SAYEED SINPC/ENG/0001/2017			

Proposal Basic Information	
Proposal File No.	SINPC/BP/0111/W18/2019
Owner Name	MD AQUIB AHMAD
Khata No	19
Plot No	1070/1071
Village Name	Simdega
Use	Residential
SubUse	Residential Bldg/Apartment

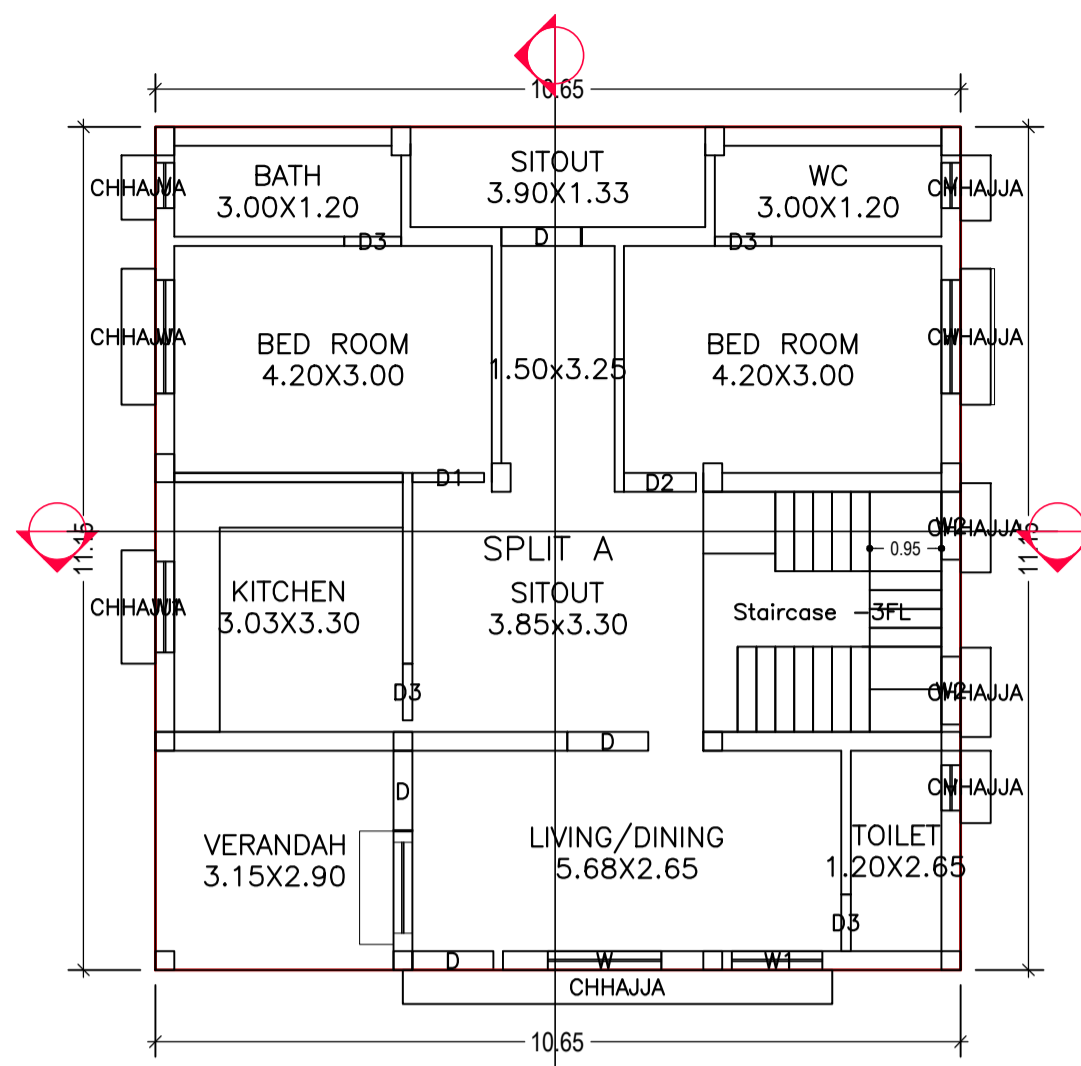

GROUND FLOOR PLAN (Proposed) (SCALE 1:100)

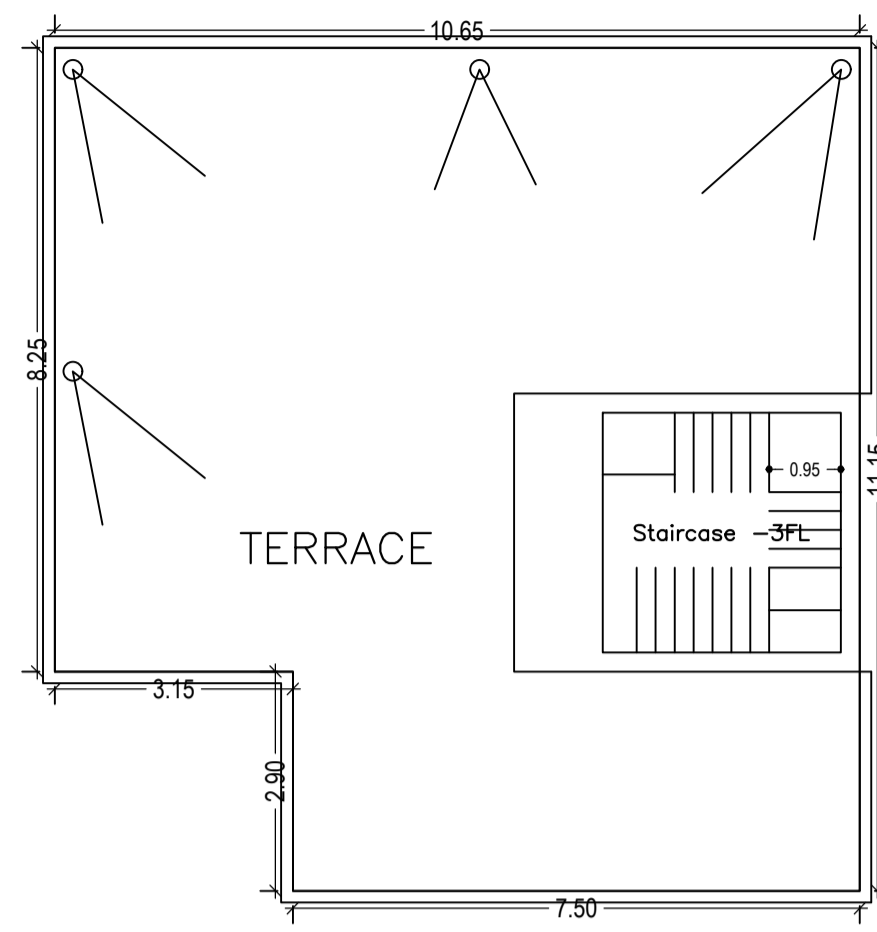

TERRACE FLOOR PLAN (SCALE 1:100)

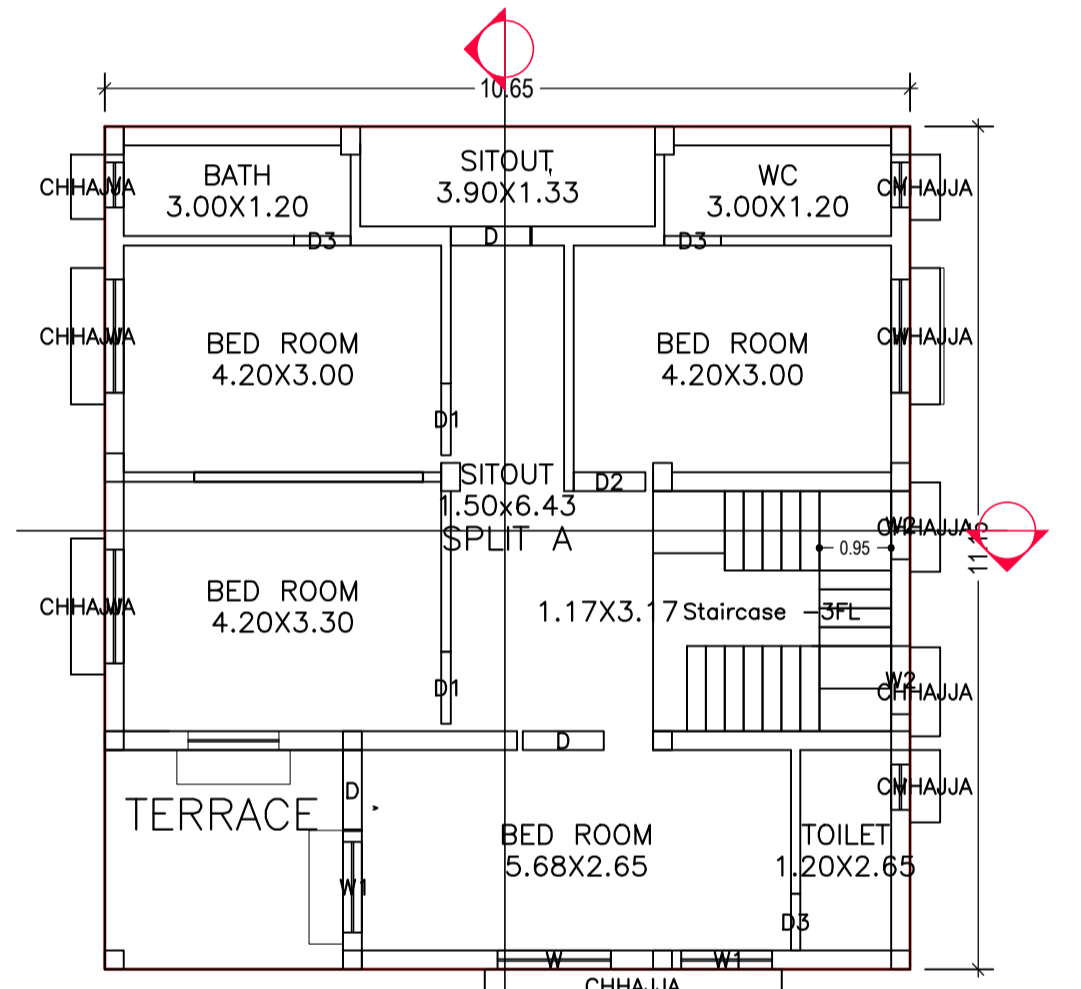

FIRST FLOOR PLAN (Proposed) (SCALE 1:100)

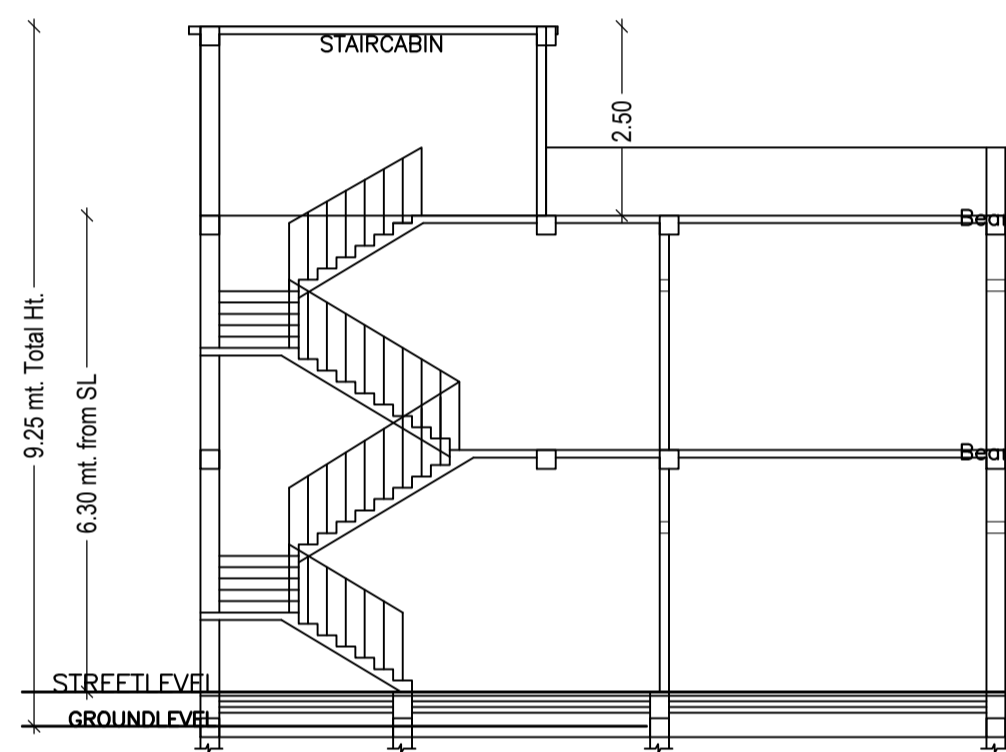

SECTION AT X-X' 1:100

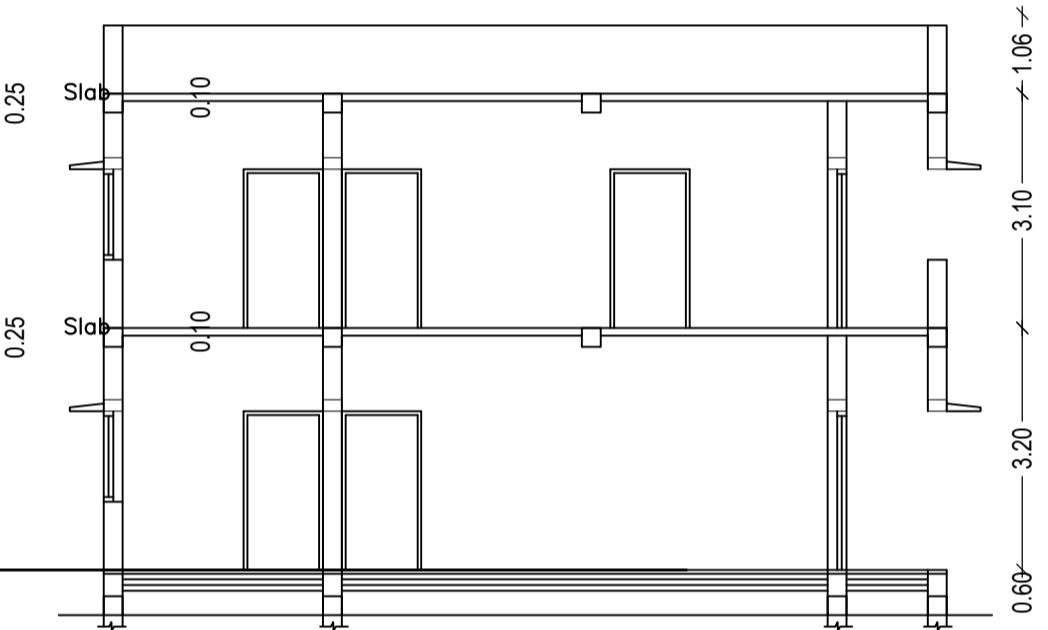

SECTION AT Y-Y' 1:100



FRONT ELEVATION 1:100

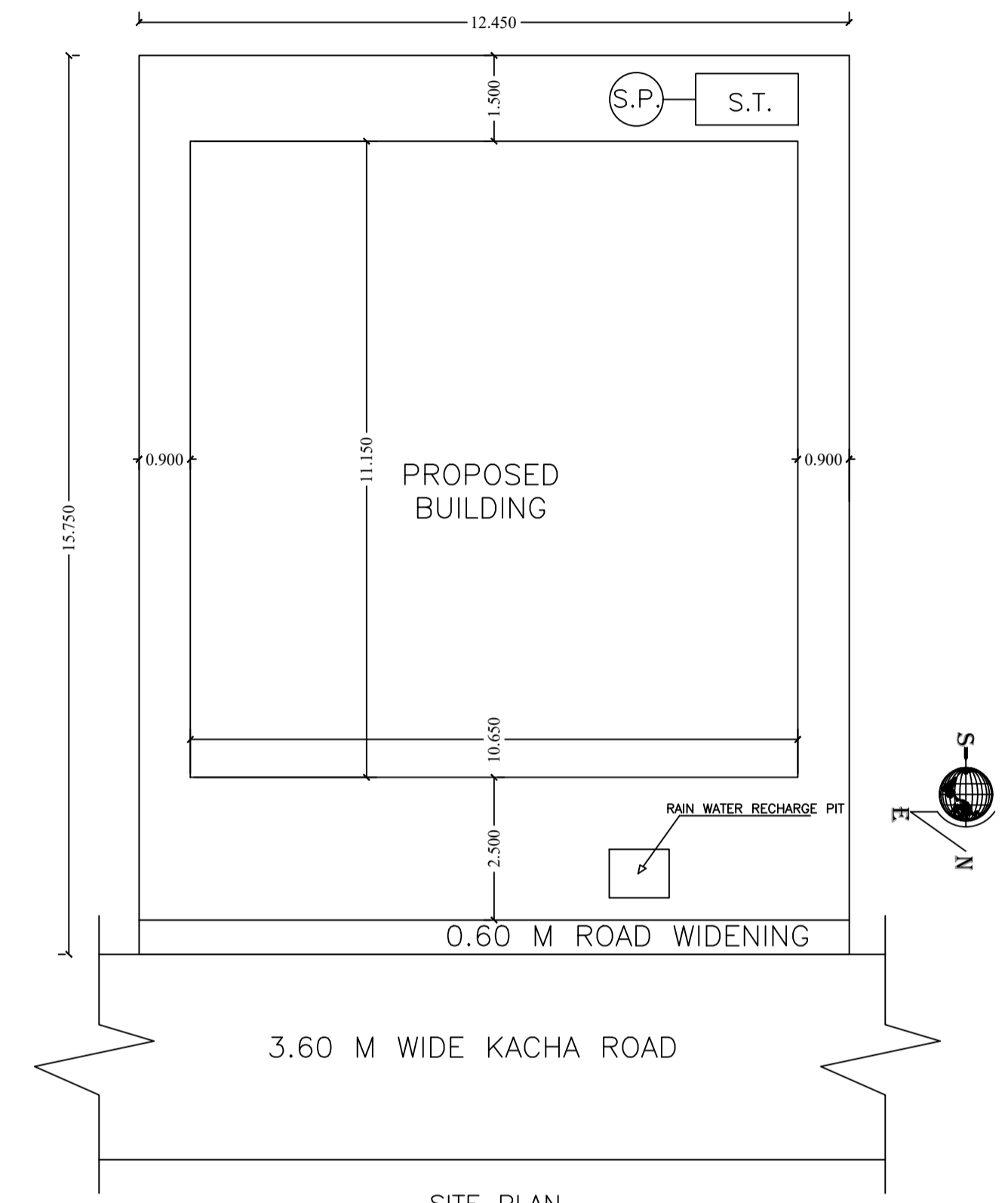
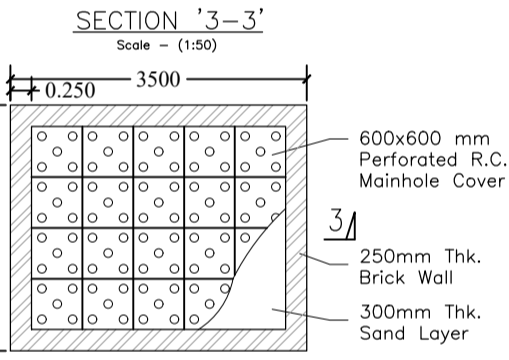
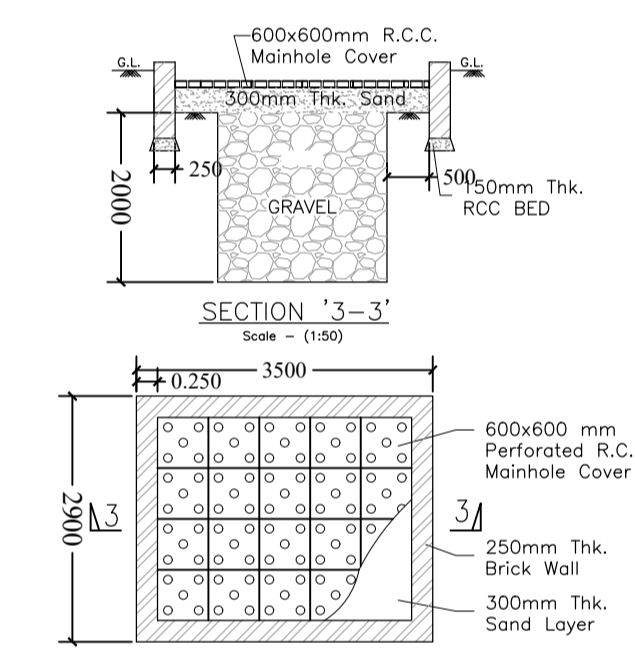

SITE PLAN 1:100

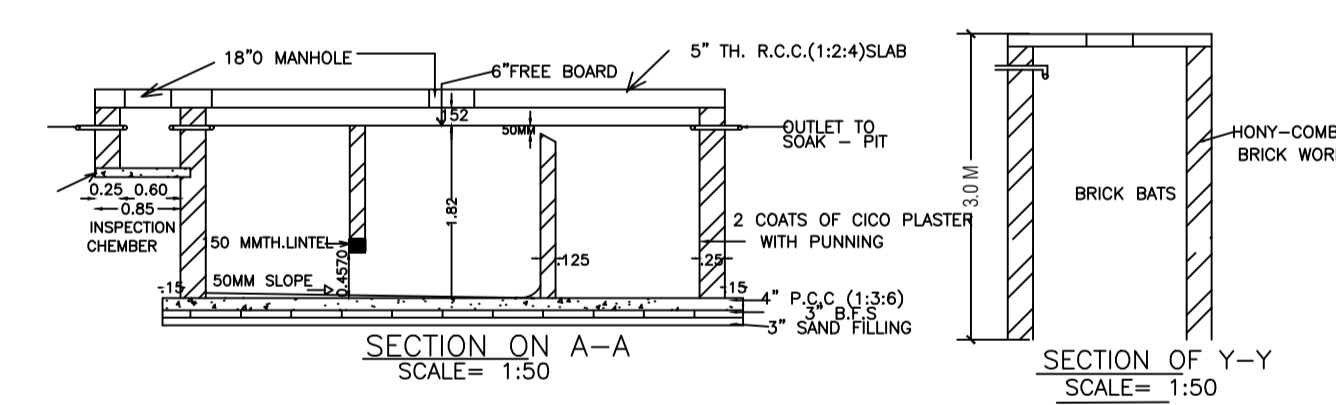

SECTION ON A-A SCALE= 1:50

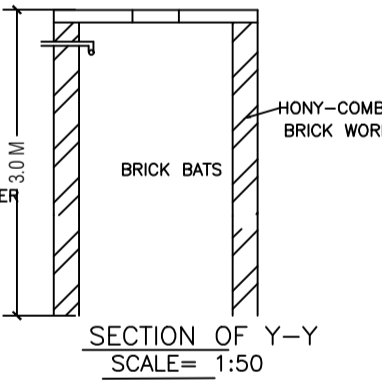

SECTION OF Y-Y SCALE= 1:50

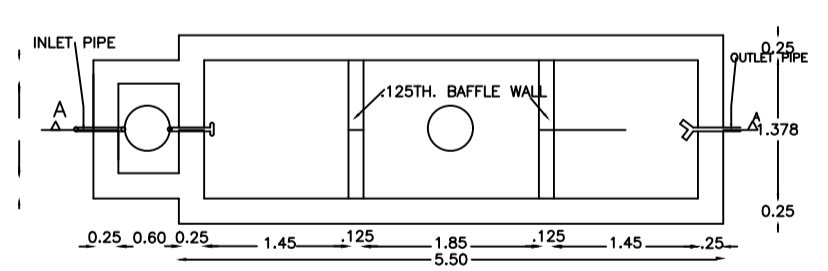

SEPTIC TANK PLAN SCALE= 1:50

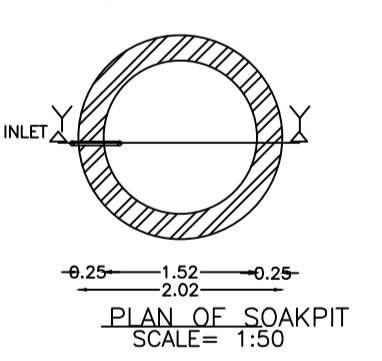

PLAN OF SOAKPIT SCALE= 1:50



SIDE ELEVATION 1:100

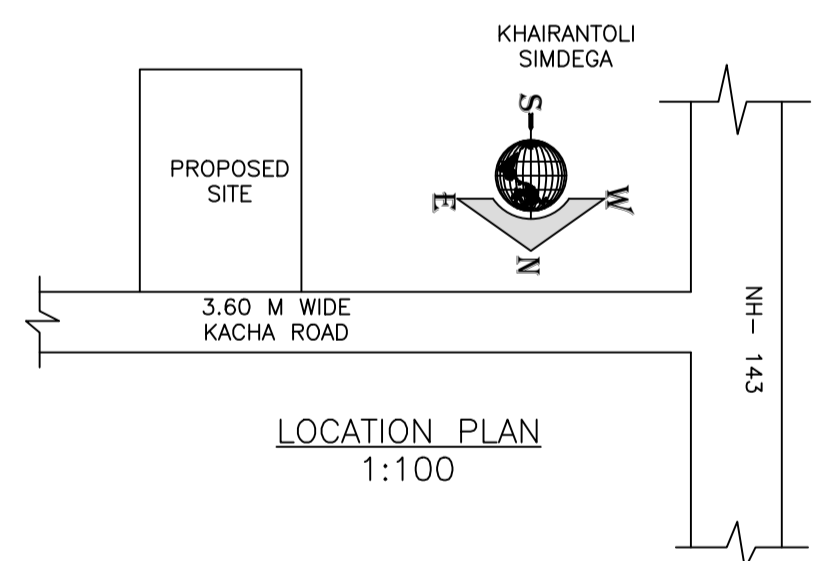

LOCATION PLAN 1:100

Building :A (AQUIB AHMAD)

Floor Name	Total Built Up Area (Sq.mt.)	Proposed FAR Area (Sq.mt.)	Total FAR Area (Sq.mt.)	Total Consumed Additional FAR Area (Sq.mt.)	Tnmt (No.)
Ground Floor	118.75	118.75	118.75	118.75	01
First Floor	109.61	109.61	109.61	109.61	00
Terrace Floor	0.00	0.00	0.00	0.00	00
Total:	228.36	228.36	228.36	228.36	01
Total Number of Same Buildings	1				
Total:	228.36	228.36	228.36	228.36	01

SCHEDULE OF DOOR:

BUILDING NAME	NAME	LENGTH	HEIGHT	NOS
A (AQUIB AHMAD)	D3	0.75	2.10	07
A (AQUIB AHMAD)	D1	0.95	2.13	03
A (AQUIB AHMAD)	D2	0.95	2.13	02
A (AQUIB AHMAD)	D	1.07	2.13	07

SCHEDULE OF WINDOW/VENTILATION:

BUILDING NAME	NAME	LENGTH	HEIGHT	NOS
A (AQUIB AHMAD)	V	0.60	2.70	06
A (AQUIB AHMAD)	W2	0.90	2.70	04
A (AQUIB AHMAD)	W1	1.20	2.70	04
A (AQUIB AHMAD)	W	1.50	2.70	07

UnitBUA Table for Building :A (AQUIB AHMAD)

FLOOR	Name	UnitBUA Type	UnitBUA Area	Carpet Area	No. of Rooms	No. of Tenement
GROUND FLOOR PLAN	SPLIT A	FLAT	187.31	186.55	10	1
FIRST FLOOR PLAN	SPLIT A	FLAT	0.00	0.00	9	0
Total:	-	-	187.31	186.55	19	1

LTP NAME AND SIGNATURE	STRUCTURAL ENG'S NAME AND SIGNATURE	BUILDER NAME AND SIGNATURE	DIGITAL SIGNATURE
MD RAGIB SAYEED SINPC/ENG/0001/2017			

Proposal Basic Information	
Proposal File No.	SINPC/BP/0111/W18/2019
Owner Name	MD AQUIB AHMAD
Khata No	19
Plot No	1070/1071
Village Name	Simdega
Use	Residential
SubUse	Residential Bldg/Apartment

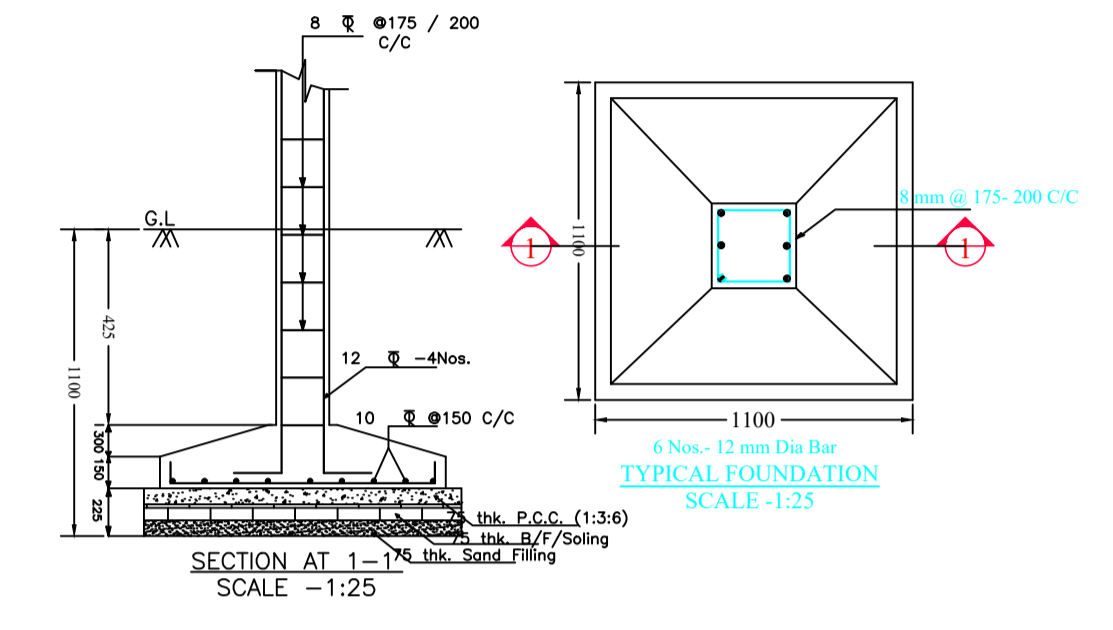

LTP NAME AND SIGNATURE	STRUCTURAL ENG'S NAME AND SIGNATURE	BUILDER NAME AND SIGNATURE	DIGITAL SIGNATURE
MD RAGIB SAYEED SINPC/ENG/0001/2017			