

SITE PLAN (SCALE=1:100)

FAR & Tenement Details (Table 4c-1)

	No. of Same Bldg	Total Built Up Area (Sq.mt)	Deductions (Area in Sq.mt.)		Proposed FAR Area (Sq.mt.)	Total FAR Area (Sq.mt.)	Total Consumed Additional FAR Area (Sq.mt.)	Trmnt (No.)
			Parking	Resi.				
A (SRI UMA SHANKAR PRASAD)	1	193.02	36.88		156.14	156.14	156.14	01
Grand Total :	1	193.02			156.14	156.14	156.14	01

Proposal Basic Information

Proposal File No.	SINPC/BP/0120/W05/2019
Owner Name	SRI UMA SHANKAR PRASAD
Khata No	109
Plot No	5095
Village Name	Simdega
Use	Residential
SubUse	Bungalow/ Dwelling / Non Apartment

AREA STATEMENT SIMDEGA NAGAR PANCHAYAT

VERSION NO: 1.0.30
VERSION DATE: 29/04/2019

Region: JHARKHAND URBAN LOCAL BODIES	Plot Use: Residential
District: SIMDEGA	Plot SubUse: Bungalow/ Dwelling / Non Apartment
Authority: SIMDEGA NAGAR PANCHAYAT	PlotNearbyReligiousStructure: NA
Inward No: SINPC/BP/0120/W05/2019	PlotSubPlot No: 5095
Application Type: General Proposal	North: -
Project Type: Building Permission	South: -
Nature of Development: New	East: -
Location of Development Area: Old Area	West: -

AREA DETAILS: SQ.MT.

AREA OF PLOT (Minimum)	(A)	161.17
Deduction for NetPlot Area		
Surrender Free of Cost		4.20
Total		4.20
NET AREA OF PLOT(Gross Plot Area - Deduction from Gross Plot area)	(A-Deductions)	156.98
Deduction for Balance Plot Area(from Gross Plot Area)		
Surrender Free of Cost		4.20
Common Plot		19.61
Total		23.81
BALANCE AREA OF PLOT(Net Plot Area - Recreational/Amenity space)	(A-Deductions)	137.36
PLOT AREA FOR COVERAGE(Net Plot Area)	(A-Deductions)	156.98
Plot Area for FAR (Net Plot Area + RoadWidening Area)	(A-Deductions)	161.17

COVERAGE CHECK

Permissible Coverage area (70.00 %)	109.89
Proposed Coverage Area (61.48 %)	96.51
Total Prop. Coverage Area (61.48 %)	96.51
Balance coverage area (8.52 %)	13.38

FAR CHECK

Perm. FAR Area (1.20)	193.40
Total Perm. FAR area	193.40
Residential FAR	156.14
Proposed FAR Area	156.14
Total Proposed FAR Area	156.14
Consumed FAR (Factor)	0.97
Balance FAR Area	37.26

BUILT UP AREA CHECK

Total Proposed BuiltUp Area	193.02
-----------------------------	--------

ARCHITECT (Regd) DEEN DAYAL GUPTA
ENGINEER (Regd)
SUPERVISOR (Regd)
OWNER (Regd) SRI UMA SHANKAR PRASAD

DEVELOPMENT AUTHORITY LOCAL BODY

COLOR INDEX

PLOT BOUNDARY	Black
ABUTTING ROAD	Green
PROPOSED CONSTRUCTION	Red
COMMON PLOT	Yellow
ROAD WIDENING AREA	Blue
EXISTING (To be retained)	Blue
EXISTING (To be demolished)	Yellow

Buildingwise Floor FAR Details

Floor Name	Building Name A (SRI UMA SHANKAR PRASAD)		Total	
	Proposed Built Up Area (Sq.mt.)	Proposed FAR Area (Sq.mt.)	Total Proposed Built Up Area (Sq.mt.)	Total FAR Area (Sq.mt.)
Ground Floor	96.51	59.63	96.51	59.63
First Floor	96.51	96.51	96.51	96.51
Terrace Floor	0.00	0.00	0.00	0.00
Total	193.02	156.14	193.02	156.14

Building USE/SUBUSE Details

Building Name	Building Use	Building SubUse	Building Structure
A (SRI UMA SHANKAR PRASAD)	Residential	Bungalow/ Dwelling / Non Apartment	Non-Highrise

LTP NAME AND SIGNATURE	STRUCTURAL ENG'S NAME AND SIGNATURE	BUILDER NAME AND SIGNATURE	DIGITAL SIGNATURE
DEEN DAYAL GUPTA SINPC/ENG/0008/2017			

Proposal Basic Information	
Proposal File No.	SINPC/BP/0120/W05/2019
Owner Name	SRI UMA SHANKAR PRASAD
Khata No	109
Plot No	5095
Village Name	Simdega
Use	Residential
SubUse	Bungalow/ Dwelling / Non Apartment

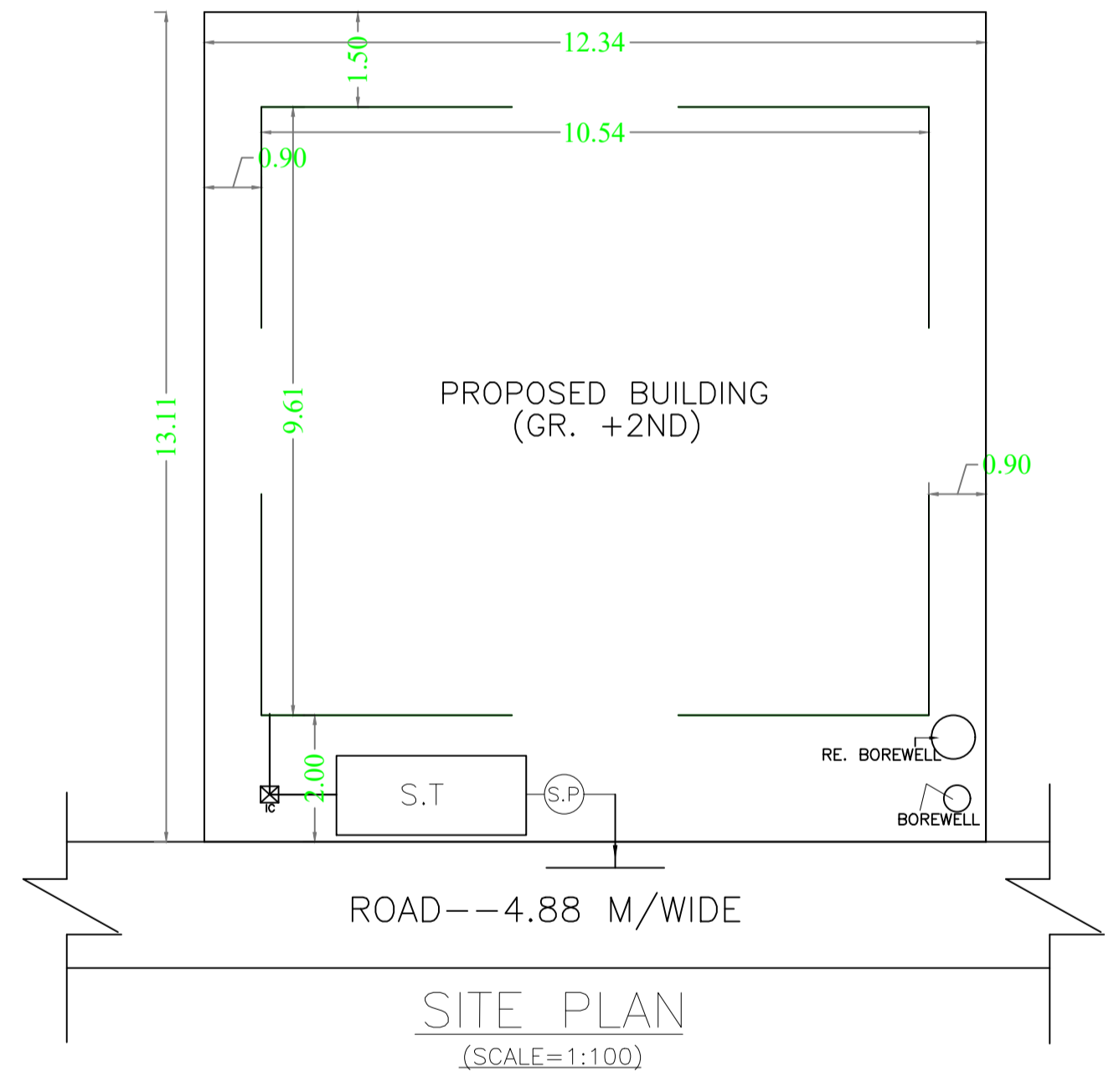
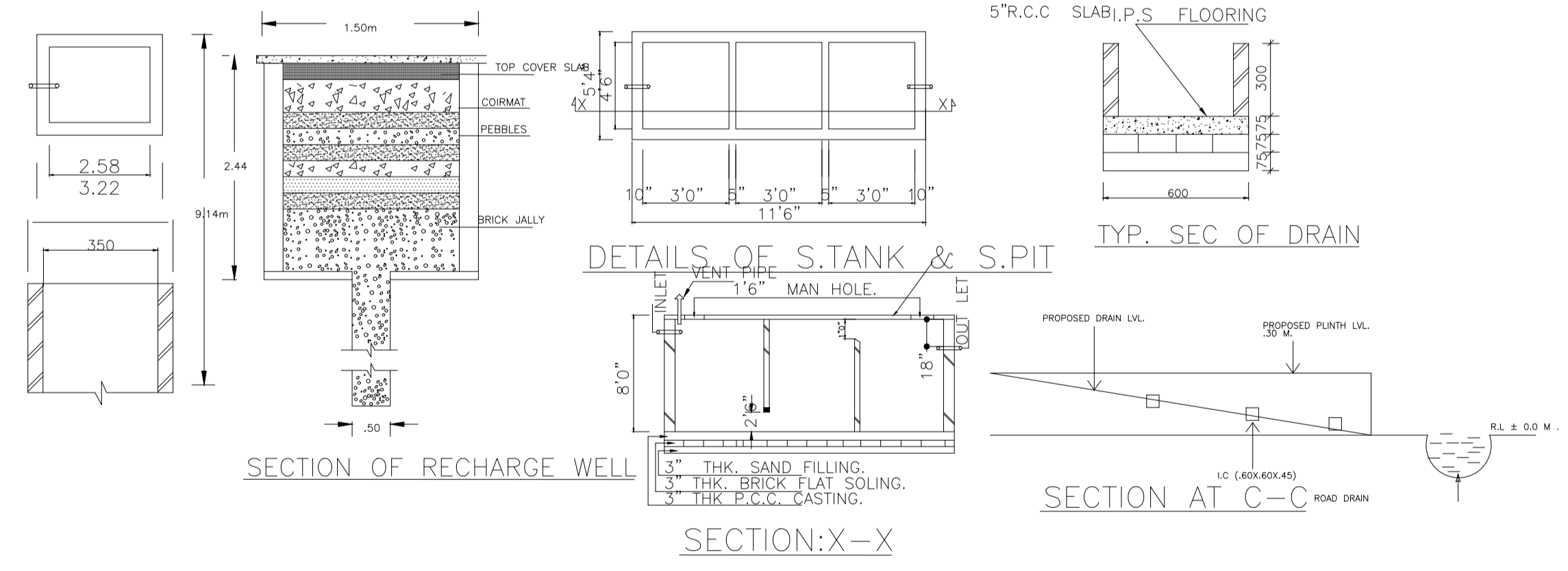
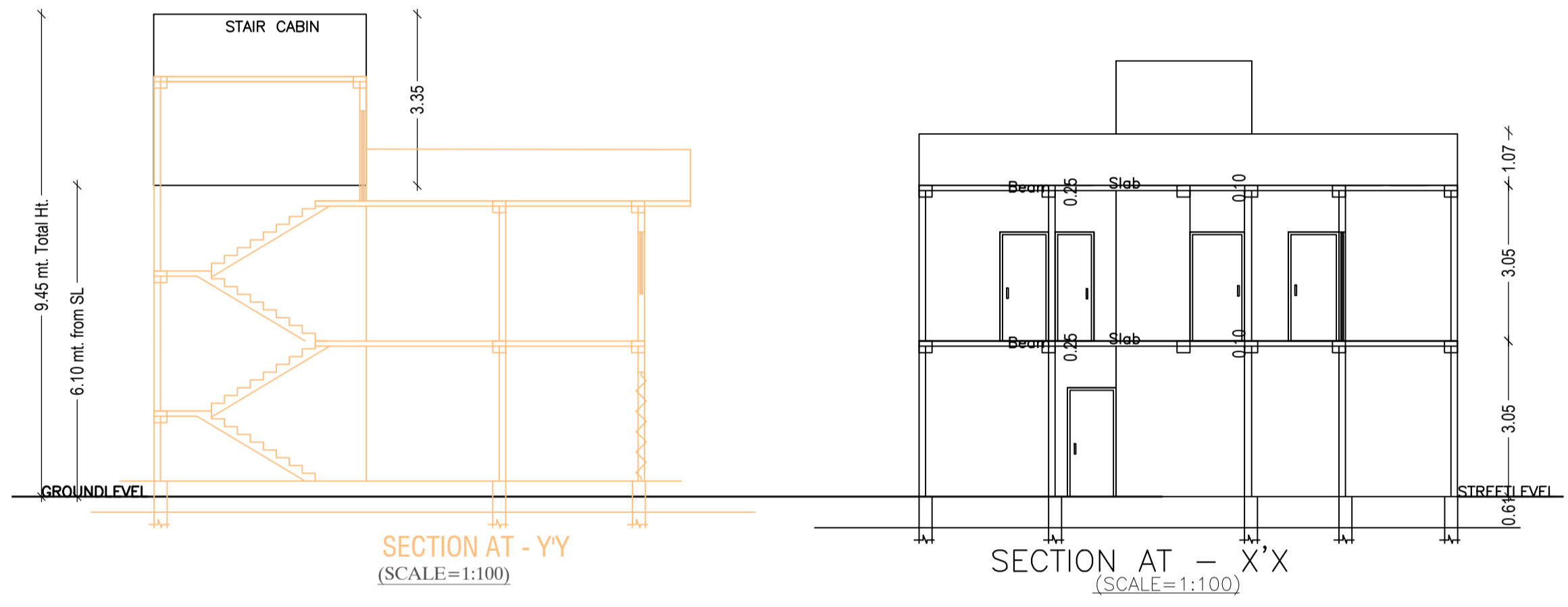
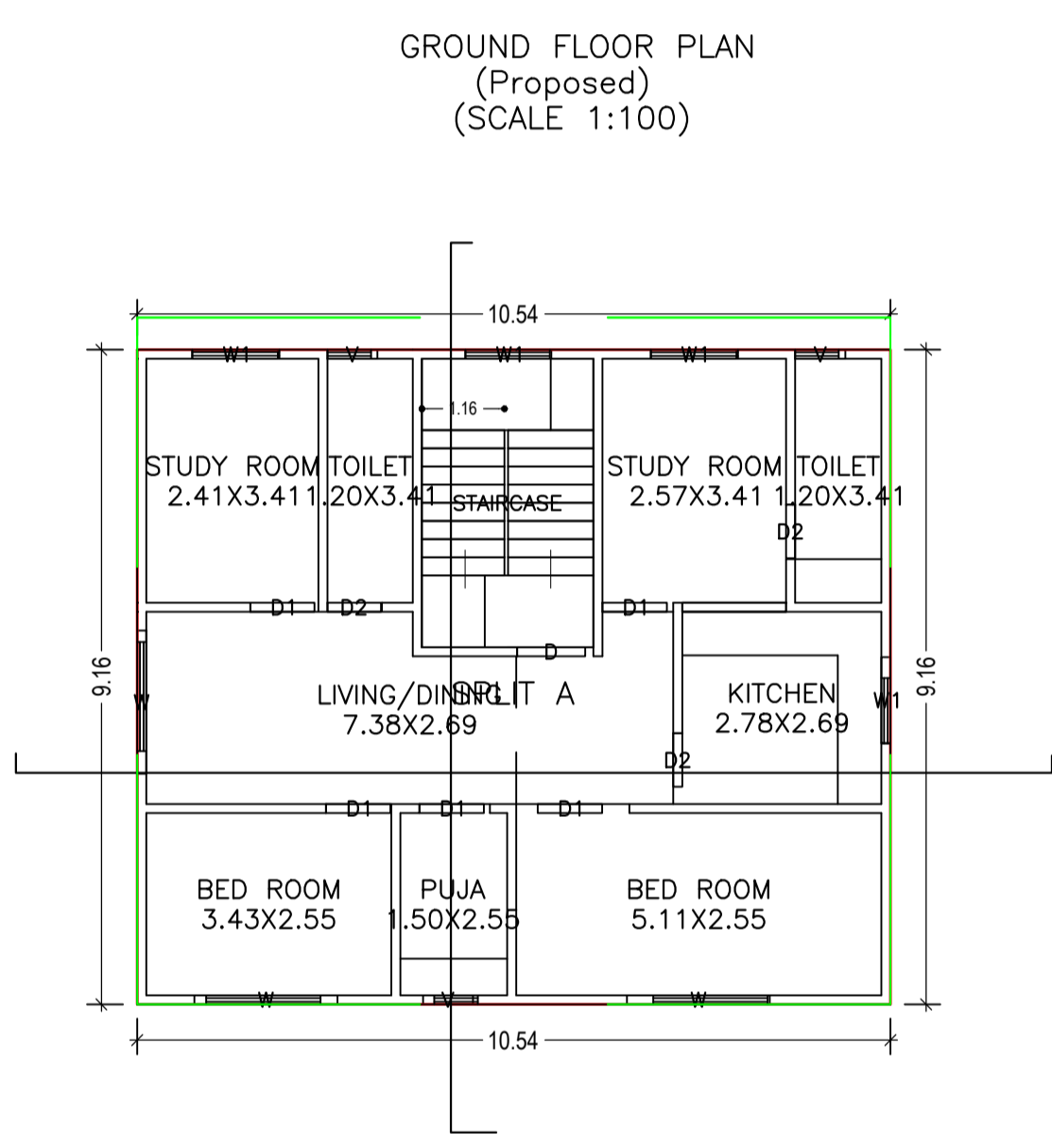
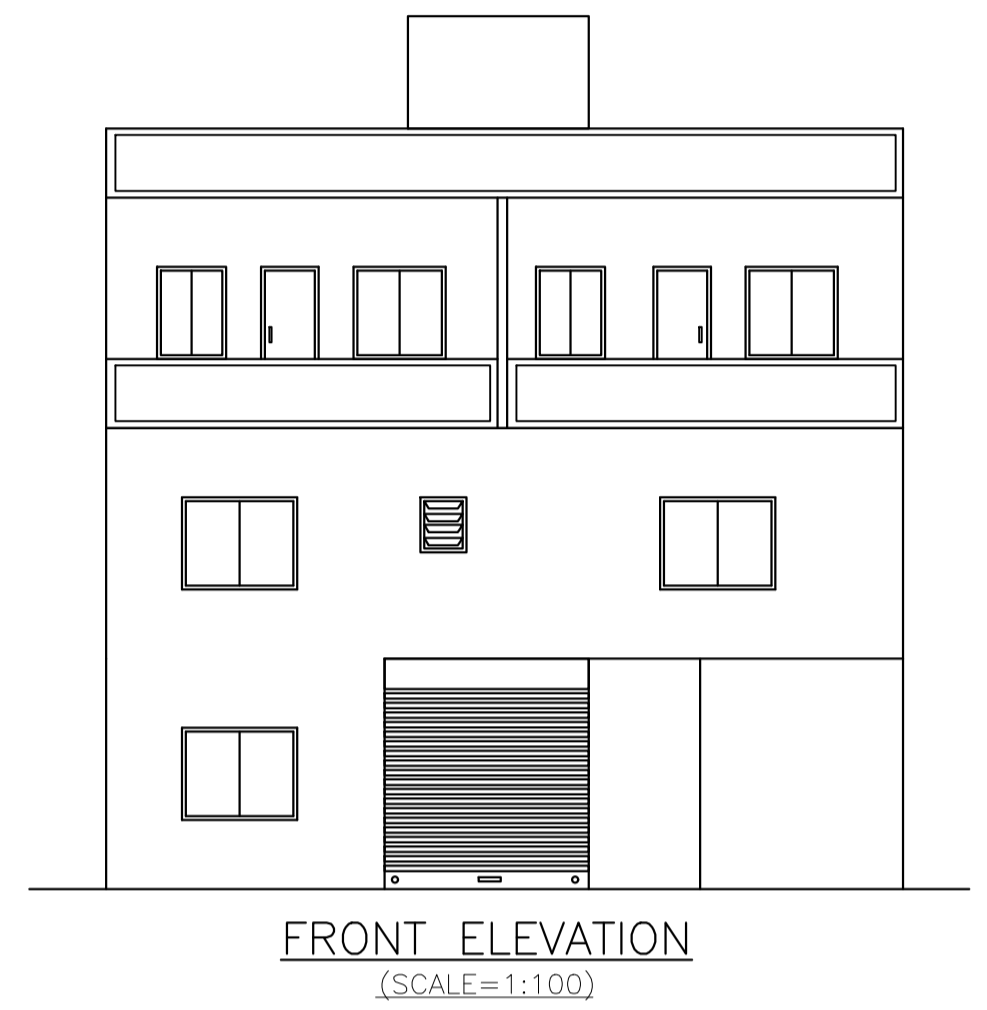
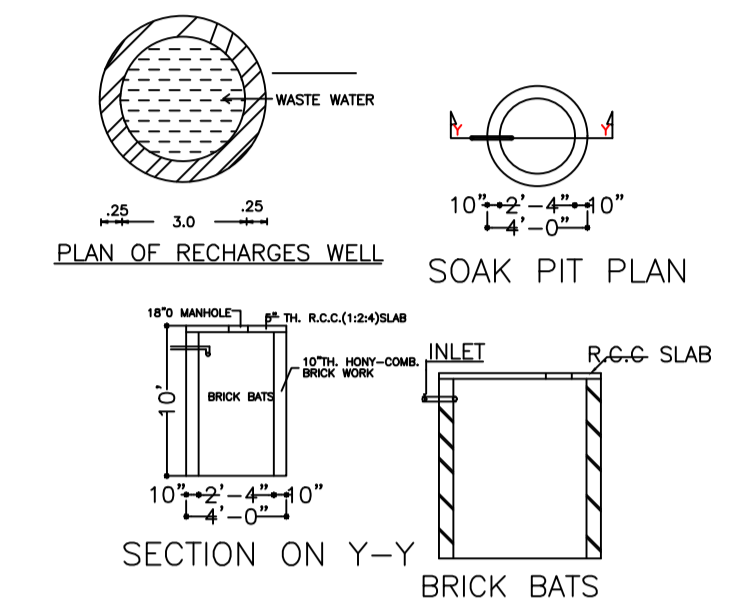
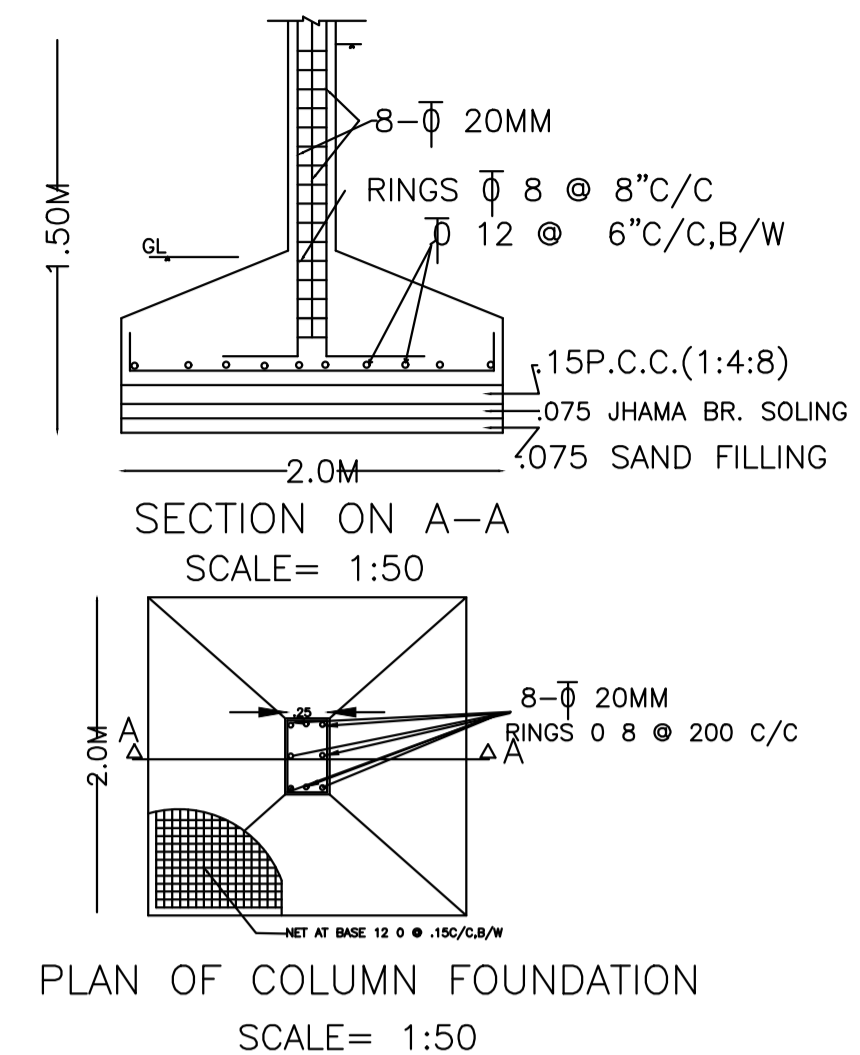
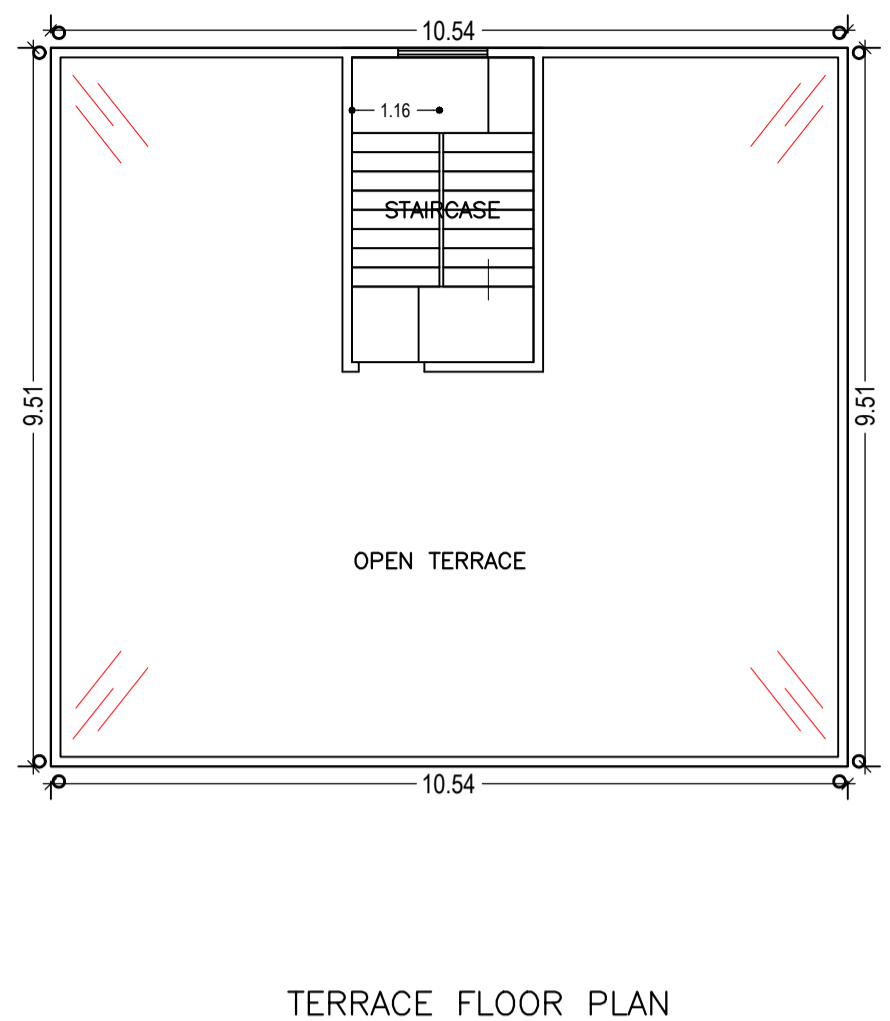
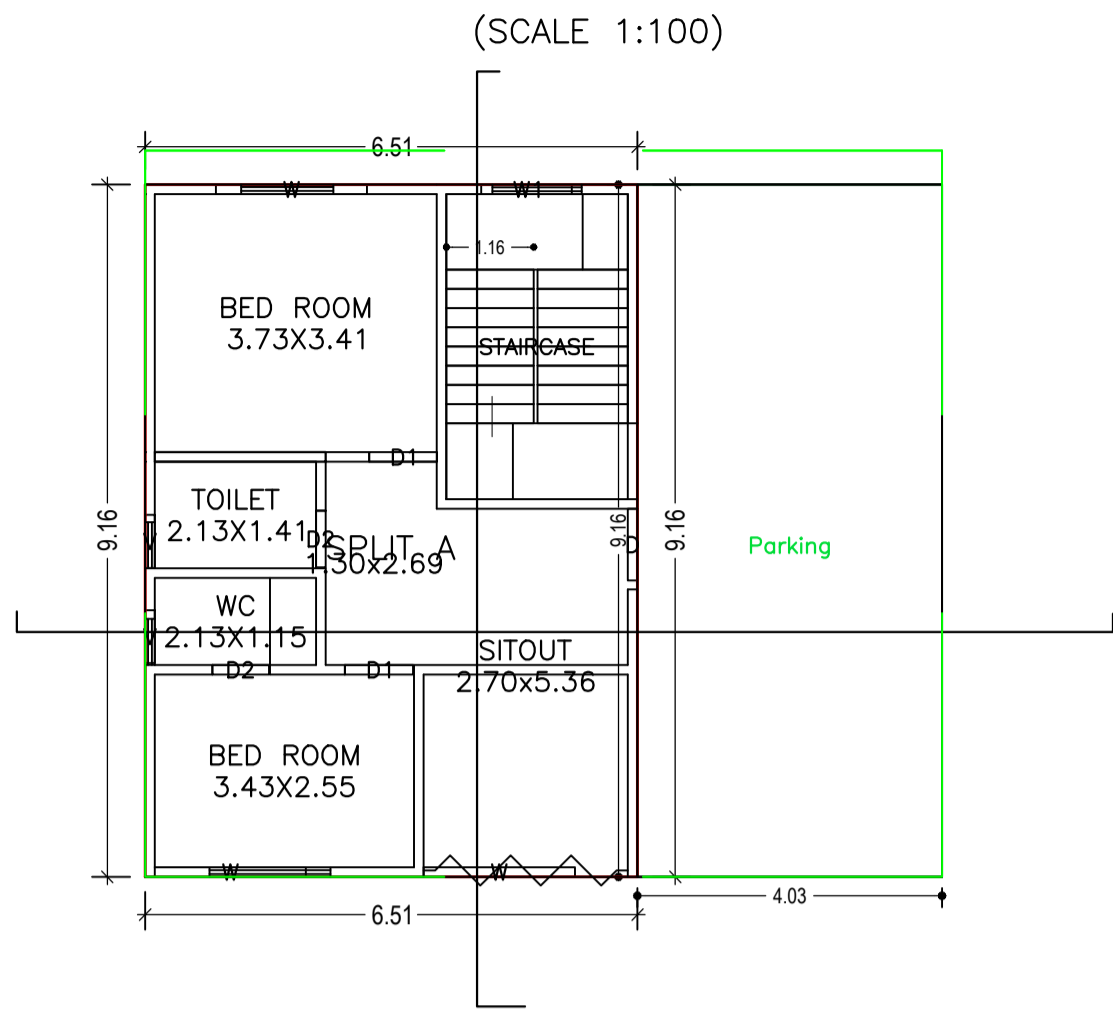

Building :A (SRI UMA SHANKAR PRASAD)

Floor Name	Total Built Up Area (Sq.mt.)	Deductions (Area in Sq.mt.)	Proposed FAR Area (Sq.mt.)	Total FAR Area (Sq.mt.)	Total Consumed Additional FAR Area (Sq.mt.)	Trmt (No.)
Ground Floor	96.51	36.88	59.63	59.63	59.63	01
First Floor	96.51	0.00	96.51	96.51	96.51	00
Terrace Floor	0.00	0.00	0.00	0.00	0.00	00
Total :	193.02	36.88	156.14	156.14	156.14	01
Total Number of Same Buildings	1					
Total :	193.02	36.88	156.14	156.14	156.14	01

SCHEDULE OF DOOR:

BUILDING NAME	NAME	LENGTH	HEIGHT	NOS
A (SRI UMA SHANKAR PRASAD)	D2	0.75	2.13	05
A (SRI UMA SHANKAR PRASAD)	D1	0.90	2.13	07
A (SRI UMA SHANKAR PRASAD)	D	0.95	2.13	02

SCHEDULE OF WINDOW/VENTILATION:

BUILDING NAME	NAME	LENGTH	HEIGHT	NOS
A (SRI UMA SHANKAR PRASAD)	V	0.70	2.70	05
A (SRI UMA SHANKAR PRASAD)	W1	1.20	2.70	05
A (SRI UMA SHANKAR PRASAD)	W	2.00	2.70	06

UnitBUA Table for Building :A (SRI UMA SHANKAR PRASAD)

FLOOR	Name	UnitBUA Type	UnitBUA Area	Carpet Area	No. of Rooms	No. of Tenement
GROUND FLOOR PLAN	SPLIT A	FLAT	125.73	125.26	5	1
FIRST FLOOR PLAN	SPLIT A	FLAT	0.00	0.00	9	0
Total:	-	-	125.73	125.26	14	1

LTP NAME AND SIGNATURE	STRUCTURAL ENG'S NAME AND SIGNATURE	BUILDER NAME AND SIGNATURE	DIGITAL SIGNATURE
DEEN DAYAL GUPTA SINPC/ENG/0008/2017			

Proposal Basic Information	
Proposal File No.	SINPC/BP/0120/W05/2019
Owner Name	SRI UMA SHANKAR PRASAD
Khata No	109
Plot No	5095
Village Name	Simdega
Use	Residential
SubUse	Bungalow/ Dwelling / Non Apartment

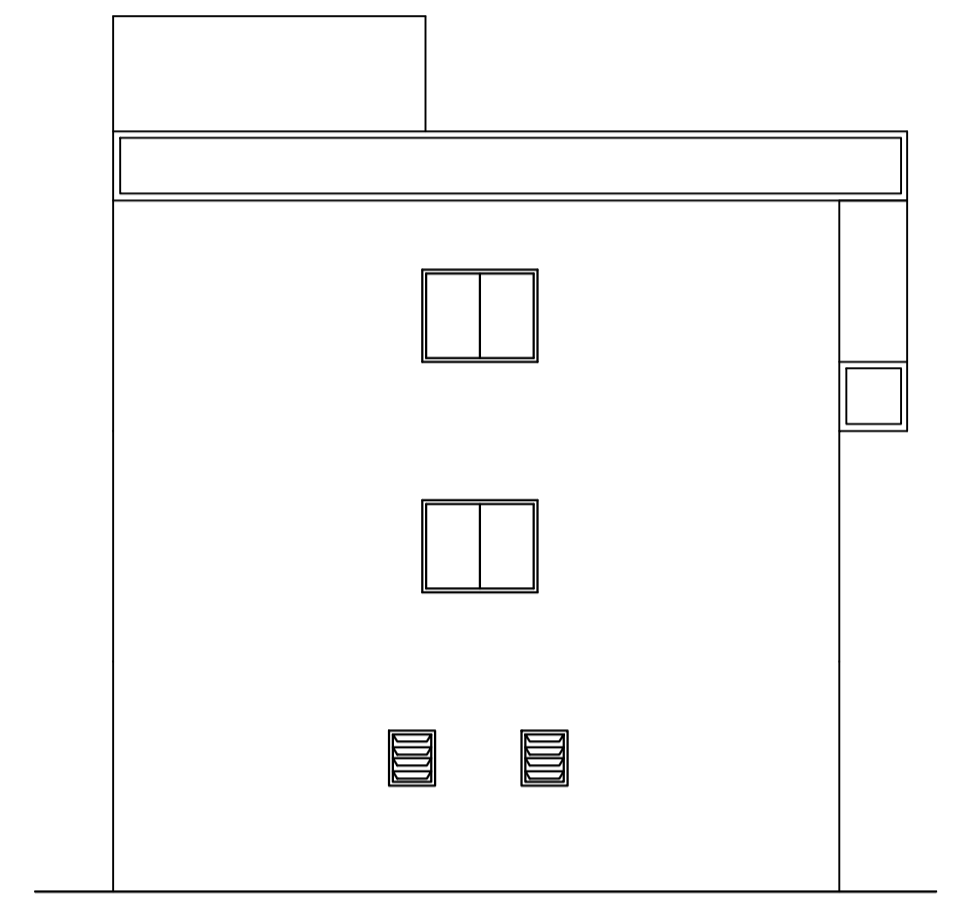

SIDE ELEVATION
(SCALE= 1:100)

LTP NAME AND SIGNATURE	STRUCTURAL ENG'S NAME AND SIGNATURE	BUILDER NAME AND SIGNATURE	DIGITAL SIGNATURE
DEEN DAYAL GUPTA SINPC/ENG/0008/2017			