

KEY PLAN
SCALE 1:100

SITE PLAN
(Scale - 1:200)

FAR & Tenement Details (Table 4c-1)

Building	No. of Same Bldg	Total Built Up Area (Sq.mt.)	Proposed FAR Area (Sq.mt.)	Total FAR Area (Sq.mt.)	Total Consumed Additional FAR Area (Sq.mt.)	Tnmt (No.)
B (MONARCH)	1	295.38	295.38	295.38	295.38	02
Grand Total :	1	295.38	295.38	295.38	295.38	02

Proposal Basic Information

Proposal File No.	SINPC/BP/0121/W02/2019
Owner Name	ASHA NILAM KULLU
Khata No	62
Plot No	4893
Village Name	Gotra
Use	Residential
SubUse	Bungalow/ Dwelling / Non Apartment

Required Parking (Table 7a)

Building Name	Type	SubUse	Area (Sq.mt.)	Units		Car		Visitors Car		TwoWheeler	
				Reqd.	Prop.	Reqd.	Prop.	Reqd./Unit	Reqd.	Prop.	Reqd./Unit
B (MONARCH)	Residential	Bungalow/ Dwelling / Non Apartment	> 0	1	2.00	1	2	-	-	-	-
				1	2.00	-	-	1	1	-	-
Total :				-	-	-	2	2	-	1	2

Parking Check (Table 7b)

Vehicle Type	Reqd.		Prop.	
	No.	Area	No.	Area
Car	-	-	2	25.00
Total Car	2	25.00	2	25.00
Visitor's Car Parking	-	-	2	25.00
Total Visitor Parking	1	12.50	2	25.00
TwoWheeler	-	-	3	6.00
Total TwoWheeler	-	-	3	6.00
Other Parking	-	-	-	121.34
Total		37.50		208.34

AREA STATEMENT SIMDEGA NAGAR PANCHAYAT	VERSION NO. : 1.0.37
PROJECT DETAIL:	VERSION DATE: 29/04/2019
Region: JHARKHAND URBAN LOCAL BODIES	Plot Use: Residential
District: SIMDEGA	Plot SubUse: Bungalow/ Dwelling / Non Apartment
Authority: SIMDEGA NAGAR PANCHAYAT	PlotNearby/ReligiousStructure: NA
Inward No: SINPC/BP/0121/W02/2019	Plot/SubPlot No: 4893
Application Type: General Proposal	North: -
Project Type: Building Permission	South: -
Nature of Development: New	East: -
Location of Development Area: Old Area	West: -
AREA DETAILS:	SQ.MT.
AREA OF PLOT (Minimum)	(A) 1573.25
Deduction for NetPlot Area	
Surrender Free of Cost	84.09
Total	84.09
NET AREA OF PLOT(Gross Plot Area - Deduction from Gross Plot area)	(A-Deductions) 1489.16
Deduction for Balance Plot Area(from Gross Plot Area)	
Surrender Free of Cost	84.09
Common Plot	113.72
Total	197.80
BALANCE AREA OF PLOT(Net Plot Area - Recreational/Amenity space)	(A-Deductions) 1375.45
PLOT AREA FOR COVERAGE(Net Plot Area)	(A-Deductions) 1489.16
Plot Area for FAR (Net Plot Area + RoadWidening Area)	(A-Deductions) 1573.25
COVERAGE CHECK	
Permissible Coverage area (50.00 %)	744.58
Proposed Coverage Area (9.92 %)	147.69
Total Prop. Coverage Area (9.92 %)	147.69
Balance coverage area (40.08 %)	596.89
FAR CHECK	
Perm. FAR Area (1.20)	1867.90
Total Perm. FAR area	1867.90
Residential FAR	295.37
Proposed FAR Area	295.37
Total Proposed FAR Area	295.37
Consumed FAR (Factor)	0.19
Balance FAR Area	1592.53
BUILT UP AREA CHECK	
Total Proposed BuiltUp Area	295.38
ARCHITECT (Regd)	RAJESH KUMAR
ENGINEER (Regd)	
SUPERVISOR (Regd)	
OWNER (Regd)	ASHA NILAM KULLU
DEVELOPMENT AUTHORITY	LOCAL BODY

COLOR INDEX	
PLOT BOUNDARY	Black
ABUTTING ROAD	Green
PROPOSED CONSTRUCTION	Red
COMMON PLOT	Yellow
ROAD WIDENING AREA	Orange
EXISTING (To be retained)	Blue
EXISTING (To be demolished)	Light Blue

Buildingwise Floor FAR Details

Floor Name	Building Name B (MONARCH)		Total	
	Proposed Built Up Area (Sq.mt.)	Proposed FAR Area (Sq.mt.)	Total Proposed Built Up Area (Sq.mt.)	Total FAR Area (Sq.mt.)
Ground Floor	147.69	147.69	147.69	147.69
First Floor	147.69	147.69	147.69	147.69
Terrace Floor	0.00	0.00	0.00	0.00
Total :	295.38	295.38	295.38	295.38

Building USE/SUBUSE Details

Building Name	Building Use	Building SubUse	Building Structure
B (MONARCH)	Residential	Bungalow/ Dwelling / Non Apartment	Non-Highrise

LTP NAME AND SIGNATURE	STRUCTURAL ENG'S NAME AND SIGNATURE	BUILDER NAME AND SIGNATURE	DIGITAL SIGNATURE
RAJESH KUMAR SINPC/DFTMN/0006/2017			

Proposal Basic Information	
Proposal File No.	SINPC/BP/0121/W02/2019
Owner Name	ASHA NILAM KULLU
Khata No	62
Plot No	4893
Village Name	Gotra
Use	Residential
SubUse	Bungalow/ Dwelling / Non Apartment

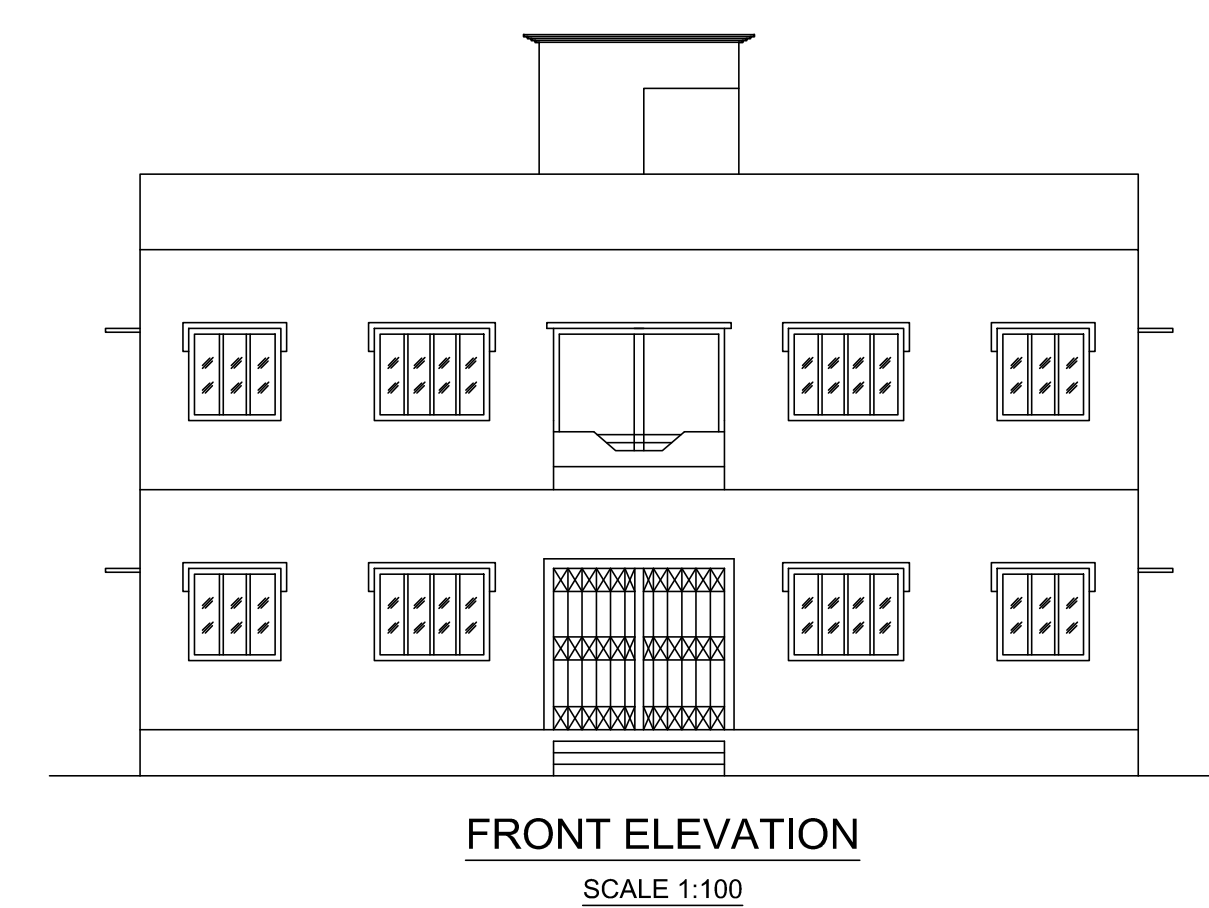
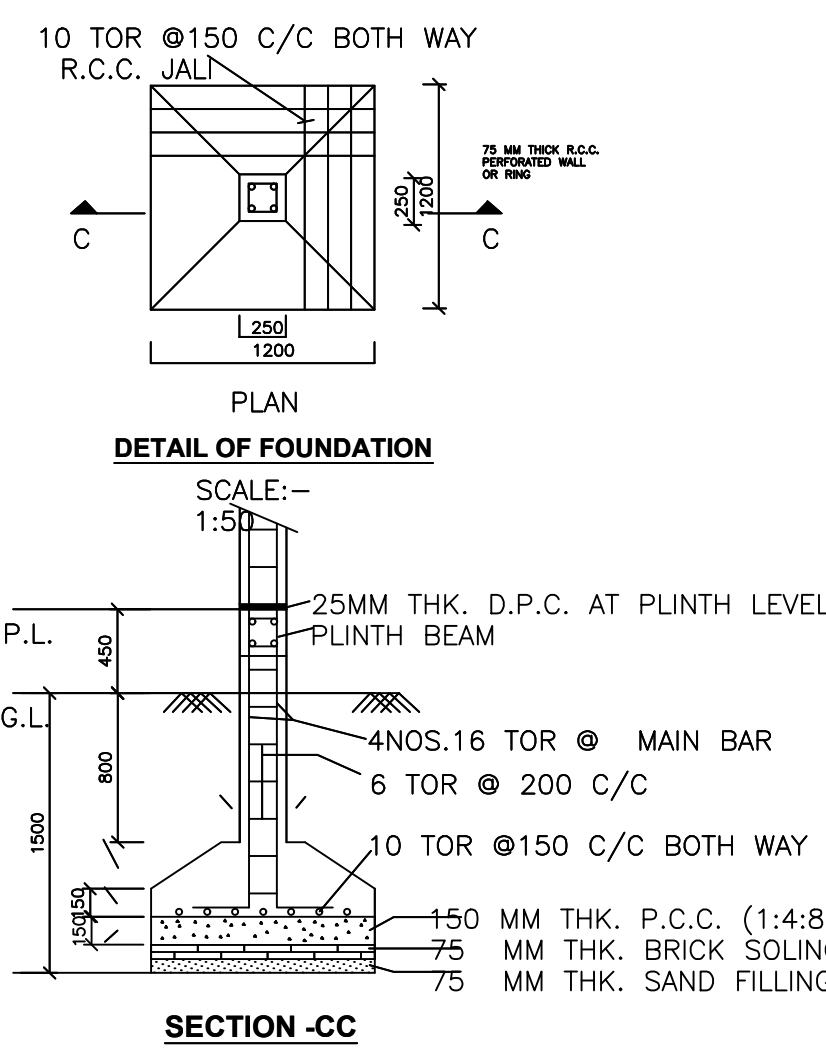
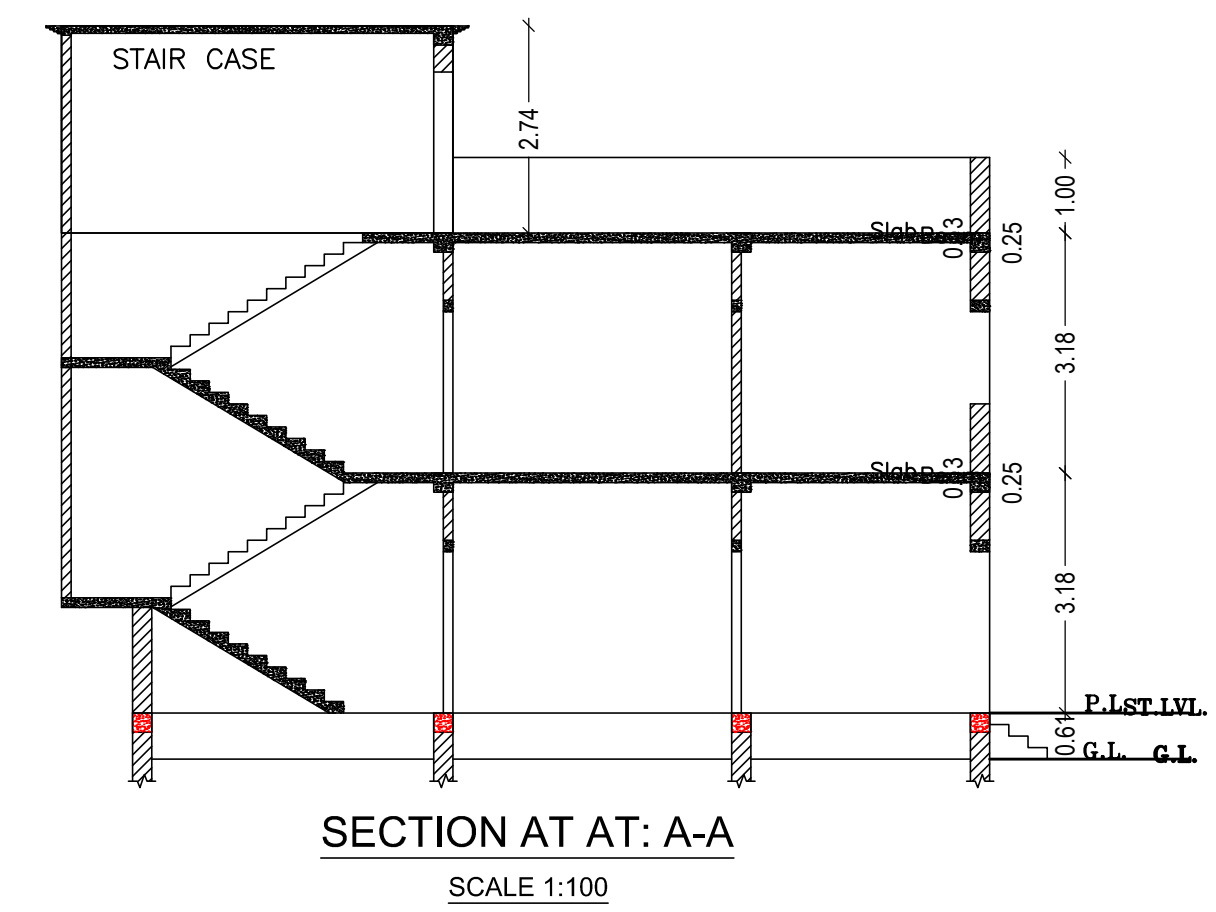
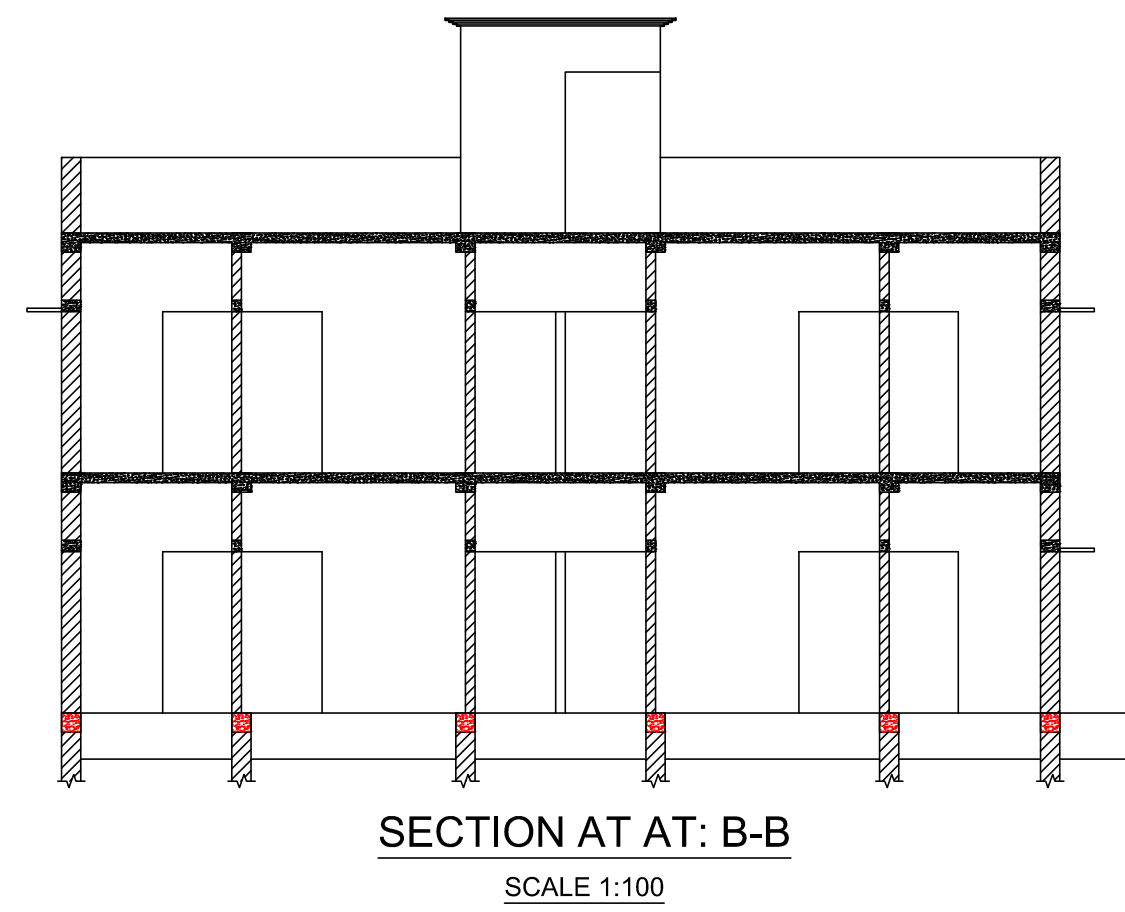
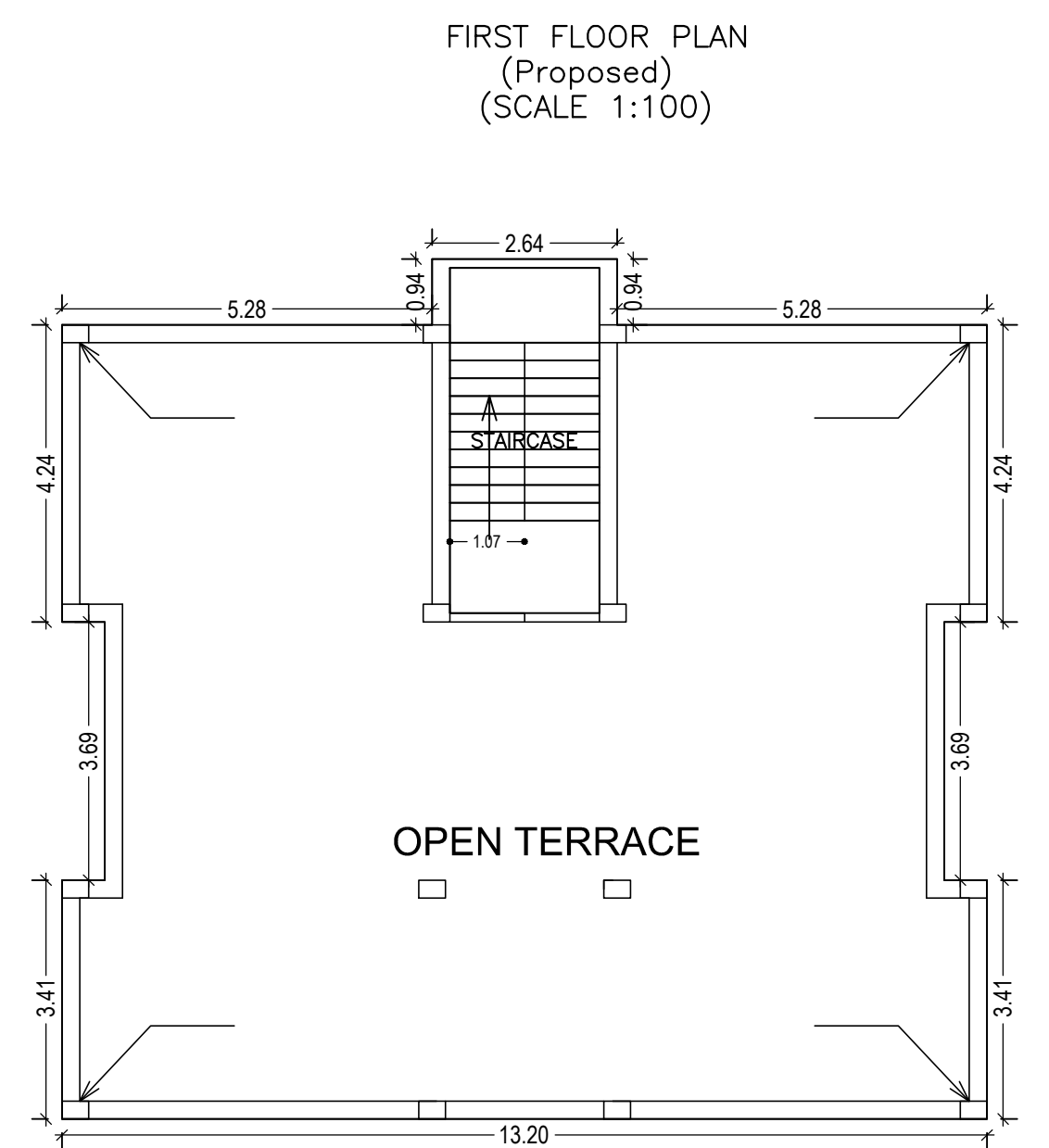
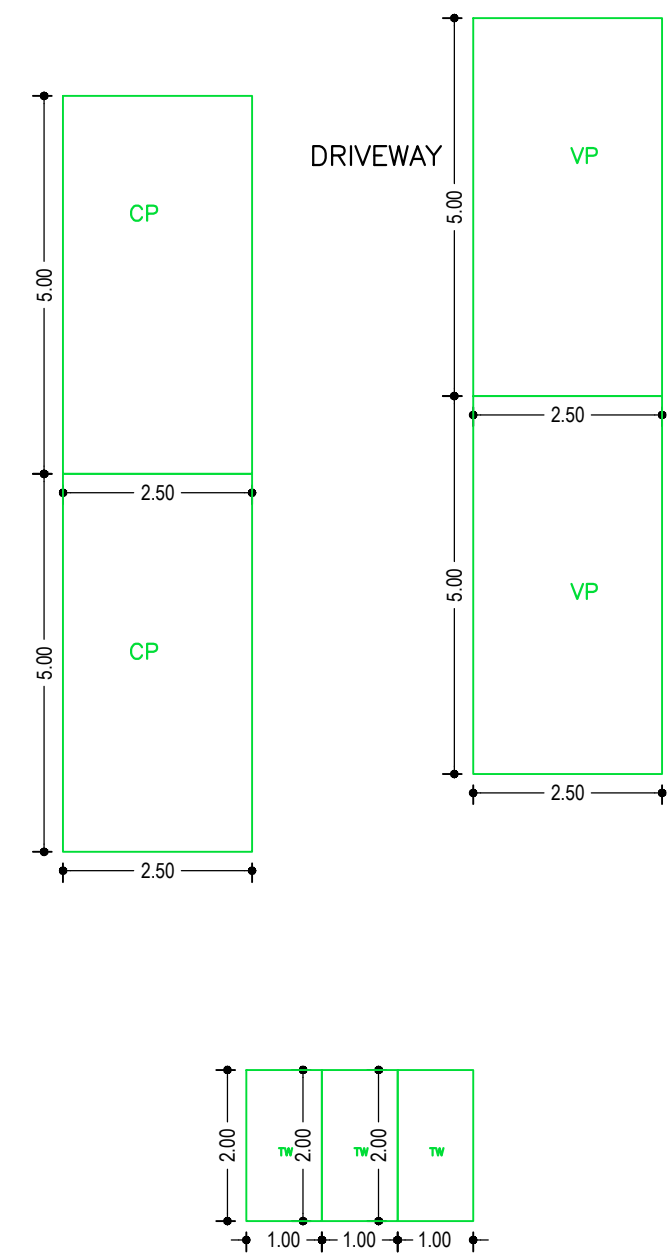
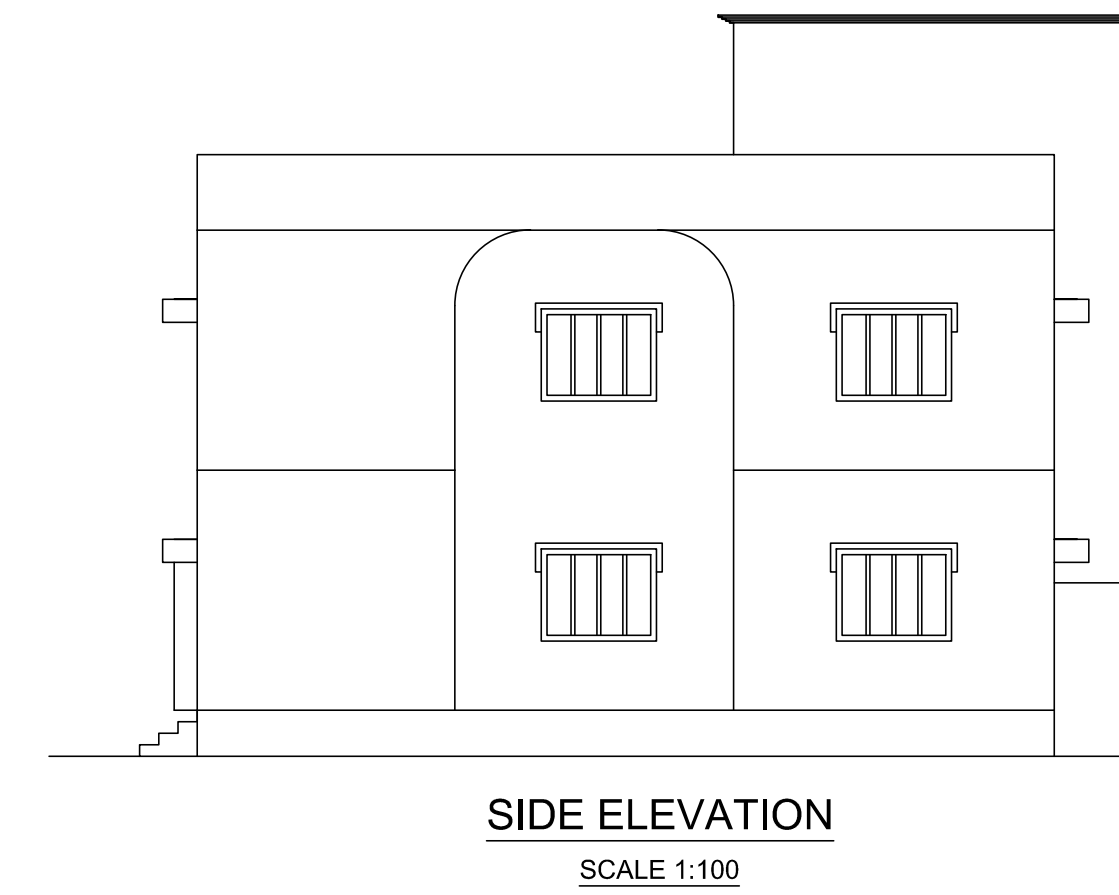
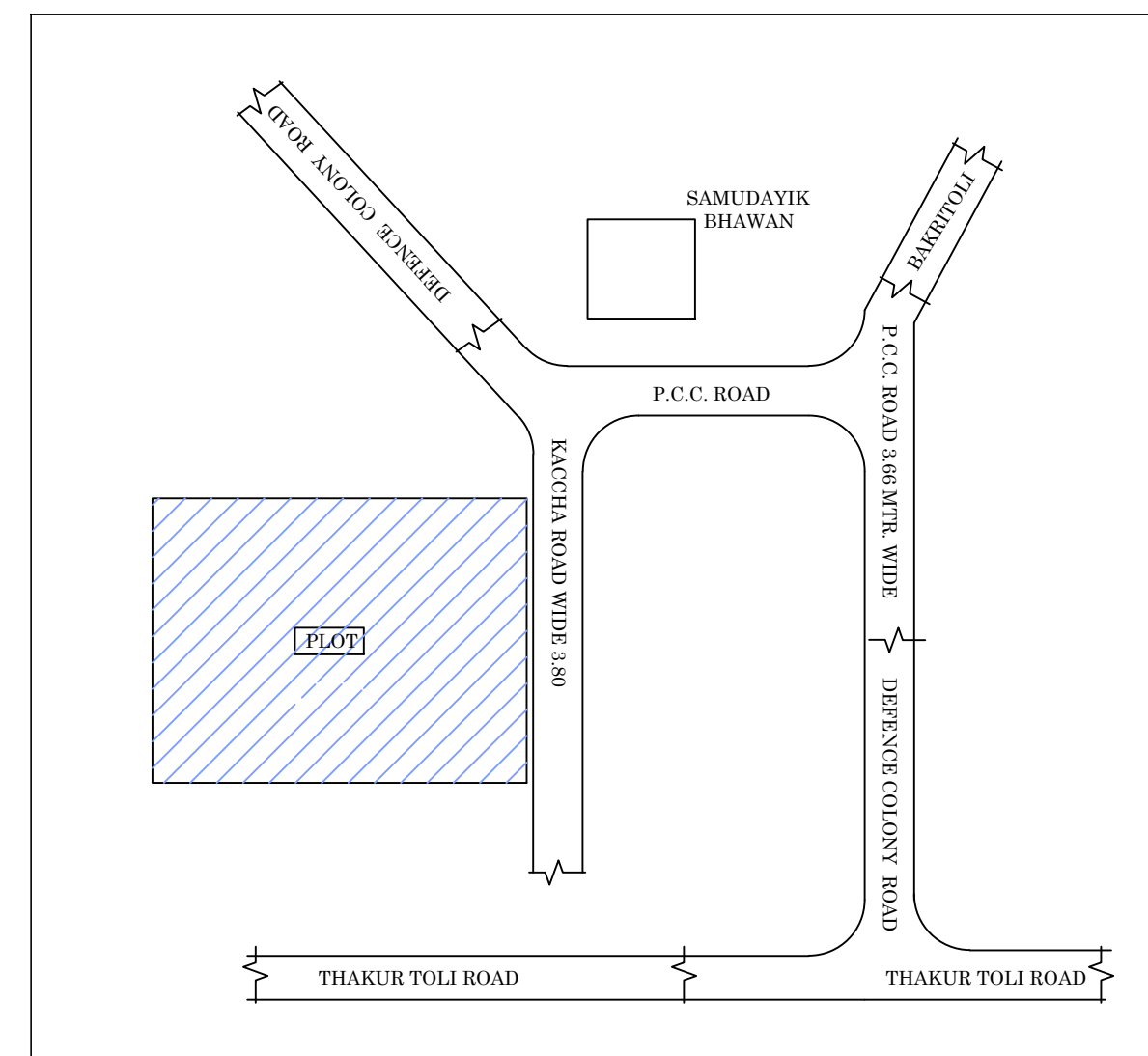
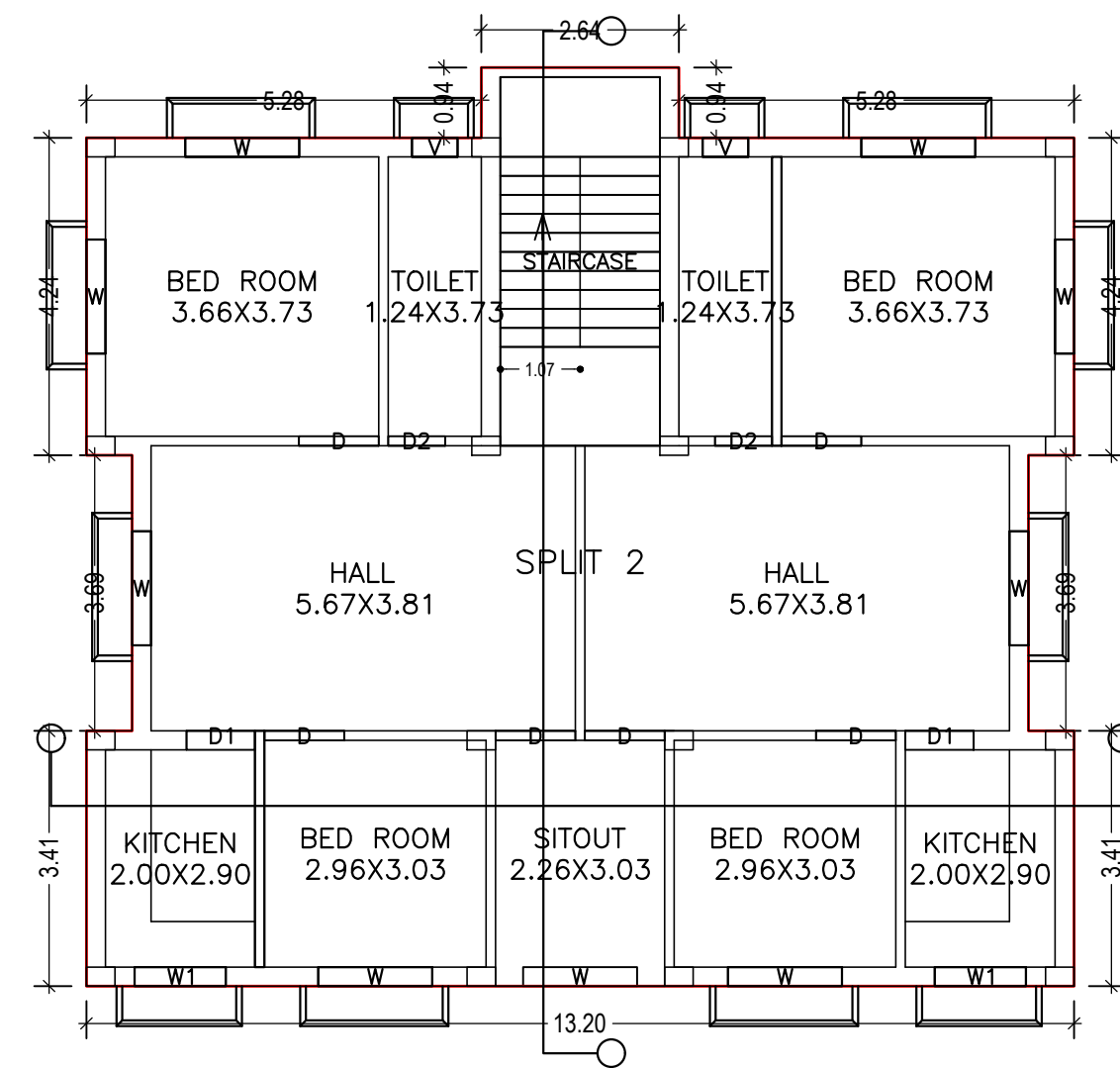
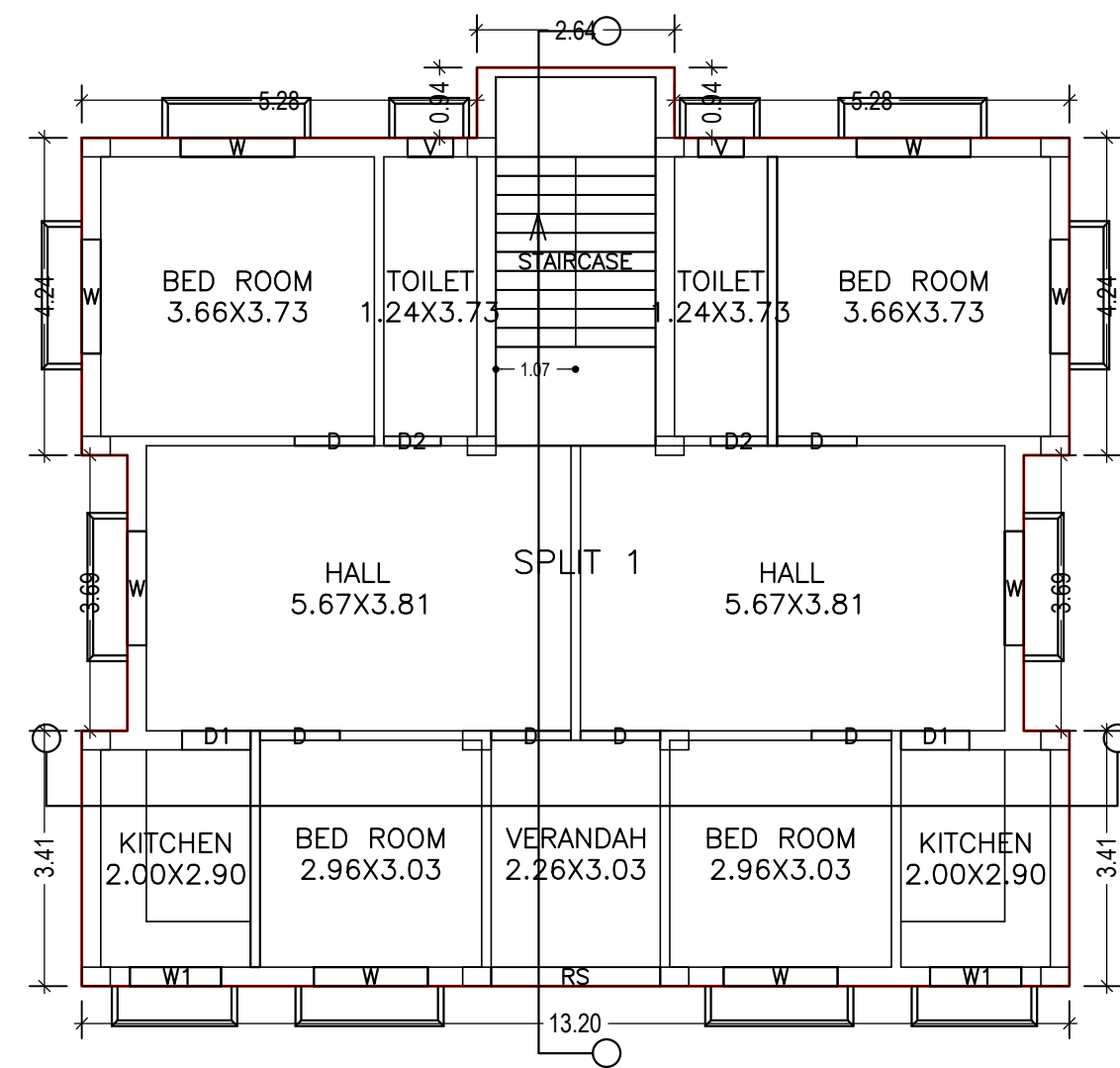

Building :B (MONARCH)

Floor Name	Total Built Up Area (Sq.mt.)	Proposed FAR Area (Sq.mt.)	Total FAR Area (Sq.mt.)	Total Consumed Additional FAR Area (Sq.mt.)	Tnmt (No.)
Ground Floor	147.69	147.69	147.69	147.69	01
First Floor	147.69	147.69	147.69	147.69	01
Terrace Floor	0.00	0.00	0.00	0.00	00
Total :	295.38	295.38	295.38	295.38	02
Total Number of Same Buildings :	1				
Total :	295.38	295.38	295.38	295.38	02

SCHEDULE OF DOOR:

BUILDING NAME	NAME	LENGTH	HEIGHT	NOS
B (MONARCH)	D2	0.76	2.10	04
B (MONARCH)	D1	0.91		04
B (MONARCH)	D	1.07	2.10	12
B (MONARCH)	RS	2.26	2.10	01

SCHEDULE OF WINDOW/VENTILATION:

BUILDING NAME	NAME	LENGTH	HEIGHT	NOS
B (MONARCH)	V	0.61	1.20	04
B (MONARCH)	W1	1.22	1.20	04
B (MONARCH)	W	1.52	1.20	17

UnitBUA Table for Building :B (MONARCH)

FLOOR	Name	UnitBUA Type	UnitBUA Area	Carpet Area	No. of Rooms	No. of Tenement
GROUND FLOOR PLAN	SPLIT 1	FLAT	122.18	121.29	11	1
FIRST FLOOR PLAN	SPLIT 2	FLAT	122.18	121.29	11	1
Total:	-	-	244.36	242.58	22	2

LTP NAME AND SIGNATURE	STRUCTURAL ENG'S NAME AND SIGNATURE	BUILDER NAME AND SIGNATURE	DIGITAL SIGNATURE
RAJESH KUMAR SINPC/DFTMN/0006/2017			

Proposal Basic Information

Proposal File No.	SINPC/BP/0121/W02/2019
Owner Name	ASHA NILAM KULLU
Khata No	62
Plot No	4893
Village Name	Gotra
Use	Residential
SubUse	Bungalow/ Dwelling / Non Apartment

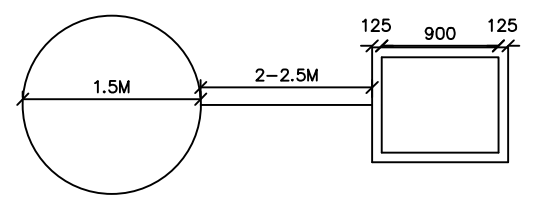

PLAN OF GROUND WATER RECHARGING PIT WITH SILT TANK

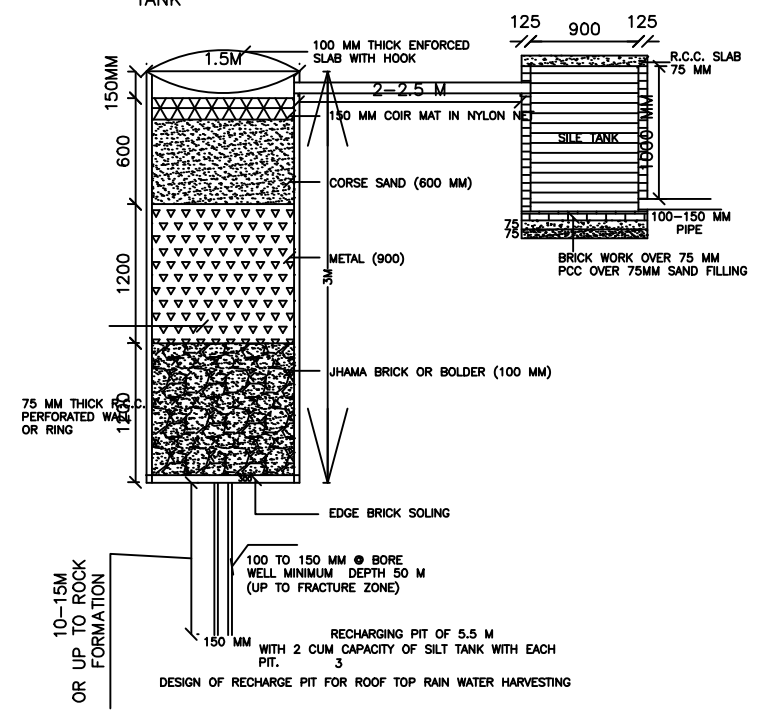

DESIGN OF RECHARGE PIT FOR ROOF TOP RAIN WATER HARVESTING

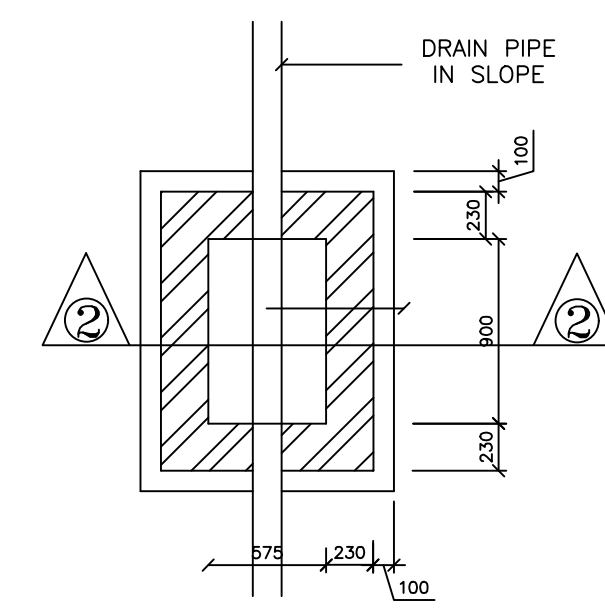

PLAN I.C.DETAILS

R.C.C. COVER

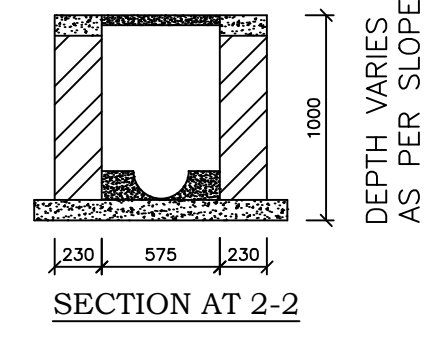

SECTION AT 2-2

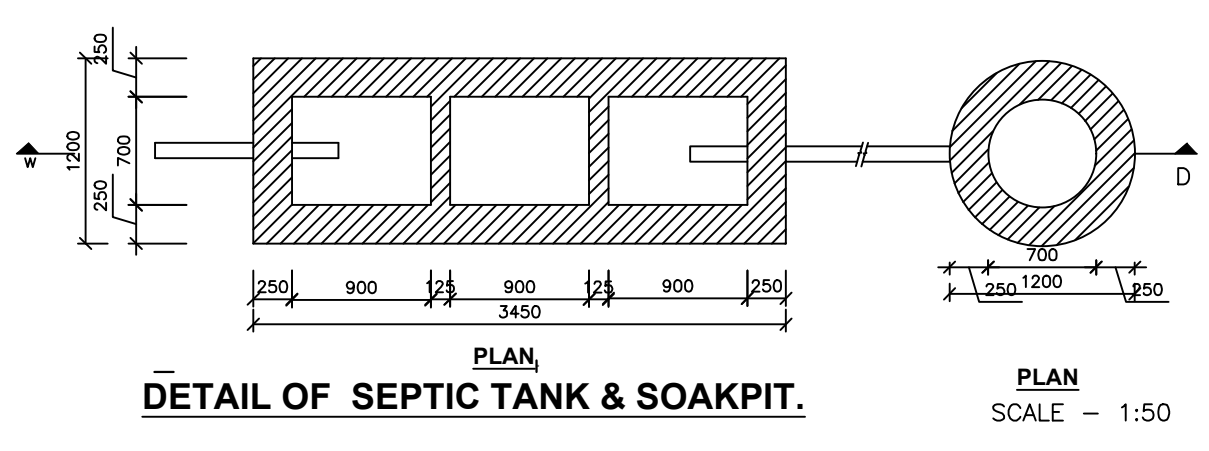

DETAIL OF SEPTIC TANK & SOAKPIT.

SCALE - 1:50

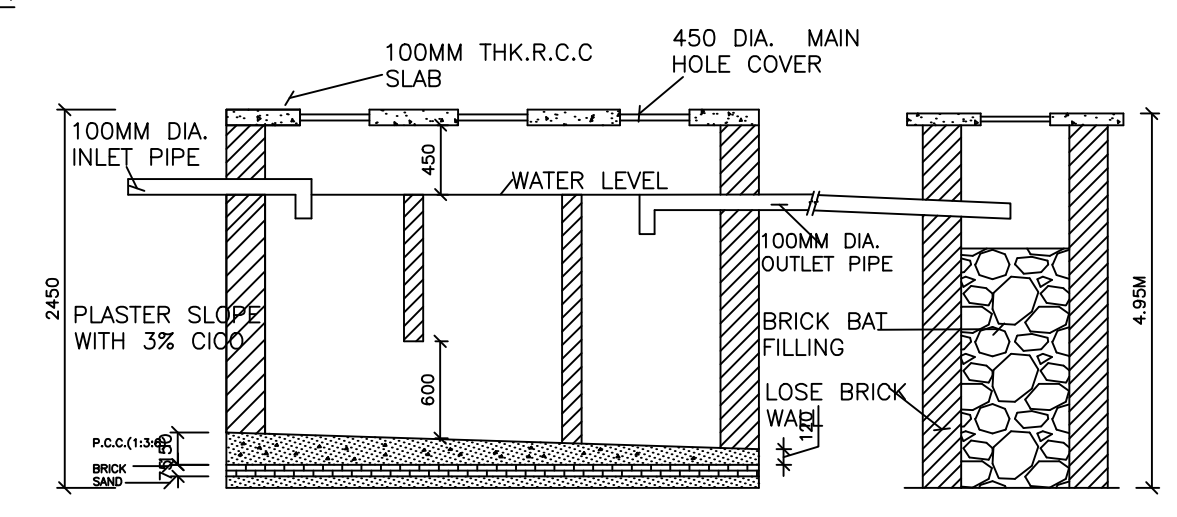

LTP NAME AND SIGNATURE	STRUCTURAL ENG'S NAME AND SIGNATURE	BUILDER NAME AND SIGNATURE	DIGITAL SIGNATURE
RAJESH KUMAR SINPC/DFTMN/0006/2017			