

SITE PLAN

FAR & Tenement Details (Table 4c-1)

Building	No. of Same Bldg	Total Built Up Area (Sq.mt.)	Proposed FAR Area (Sq.mt.) Resi.	Total FAR Area (Sq.mt.)	Total Consumed Additional FAR Area (Sq.mt.)	Tnmt (No.)
A1 (RESIDENCE)	1	89.91	89.91	89.91	89.91	01
Grand Total	1	89.91	89.91	89.91	89.91	01

Proposal Basic Information

Proposal File No.	SINPC/BP/0144/W01/2019
Owner Name	AMASI LAKRA
Khata No	158
Plot No	1684
Village Name	Gotra
Use	Residential
SubUse	Bungalow/ Dwelling / Non Apartment

AREA STATEMENT SIMDEGA NAGAR PANCHAYAT	VERSION NO: 1.0.43	VERSION DATE: 29/04/2019
PROJECT DETAIL		
Region: JHARKHAND URBAN LOCAL BODIES	Plot Use: Residential	
District: SIMDEGA	Plot SubUse: Bungalow/ Dwelling / Non Apartment	
Authority: SIMDEGA NAGAR PANCHAYAT	PlotNearbyReligiousStructure: NA	
Inward No: SINPC/BP/0144/W01/2019	PlotSubPlot No: 1684	
Application Type: General Proposal	North: -	
Project Type: Building Permission	South: -	
Nature of Development: New	East: -	
Location of Development Area: Old Area	West: -	
AREA DETAILS:		
AREA OF PLOT (Minimum)	(A)	398.66
Deduction for NetPlot Area		
Surrender Free of Cost		49.04
Total		49.04
NET AREA OF PLOT(Gross Plot Area - Deduction from Gross Plot area)	(A-Deductions)	349.62
Deduction for Balance Plot Area(from Gross Plot Area)		
Surrender Free of Cost		49.04
Common Plot		21.61
Total		70.65
BALANCE AREA OF PLOT(Net Plot Area - Recreational/Amenity space)	(A-Deductions)	328.01
PLOT AREA FOR COVERAGE(Net Plot Area)	(A-Deductions)	349.62
Plot Area for FAR (Net Plot Area + RoadWidening Area)	(A-Deductions)	398.66
COVERAGE CHECK		
Permissible Coverage area (60.00 %)		209.77
Proposed Coverage Area (25.72 %)		89.91
Total Prop. Coverage Area (25.72 %)		89.91
Balance coverage area (34.28 %)		119.86
FAR CHECK		
Perm. FAR Area (2.00)		797.32
Total Perm. FAR area		797.32
Residential FAR		89.91
Proposed FAR Area		89.91
Total Proposed FAR Area		89.91
Consumed FAR (Factor)		0.23
Balance FAR Area		707.41
BUILT UP AREA CHECK		
Total Proposed BuiltUp Area		89.91
ARCHITECT (Regd)	RAJESH KUMAR	
ENGINEER (Regd)		
SUPERVISOR (Regd)		
OWNER (Regd)	AMASI LAKRA	
DEVELOPMENT AUTHORITY		LOCAL BODY

COLOR INDEX	
PLOT BOUNDARY	Black
ABUTTING ROAD	Green
PROPOSED CONSTRUCTION	Red
COMMON PLOT	Yellow
ROAD WIDENING AREA	Orange
EXISTING (To be retained)	Blue
EXISTING (To be demolished)	Light Blue

Buildingwise Floor FAR Details

Floor Name	Building Name A1 (RESIDENCE)		Total	
	Proposed Built Up Area (Sq.mt.)	Proposed FAR Area (Sq.mt.)	Total Proposed Built Up Area (Sq.mt.)	Total FAR Area (Sq.mt.)
Ground Floor	89.91	89.91	89.91	89.91
Terrace Floor	0.00	0.00	0.00	0.00
Total	89.91	89.91	89.91	89.91

Building USE/SUBUSE Details

Building Name	Building Use	Building SubUse	Building Structure
A1 (RESIDENCE)	Residential	Bungalow/ Dwelling / Non Apartment	Non-Highrise

LTP NAME AND SIGNATURE	STRUCTURAL ENG'S NAME AND SIGNATURE	BUILDER NAME AND SIGNATURE	DIGITAL SIGNATURE
RAJESH KUMAR SINPC/DFTMN/0006/2017			

Proposal Basic Information

Proposal File No.	SINPC/BP/0144/W01/2019
Owner Name	AMASI LAKRA
Khata No	158
Plot No	1684
Village Name	Gotra
Use	Residential
SubUse	Bungalow/ Dwelling / Non Apartment

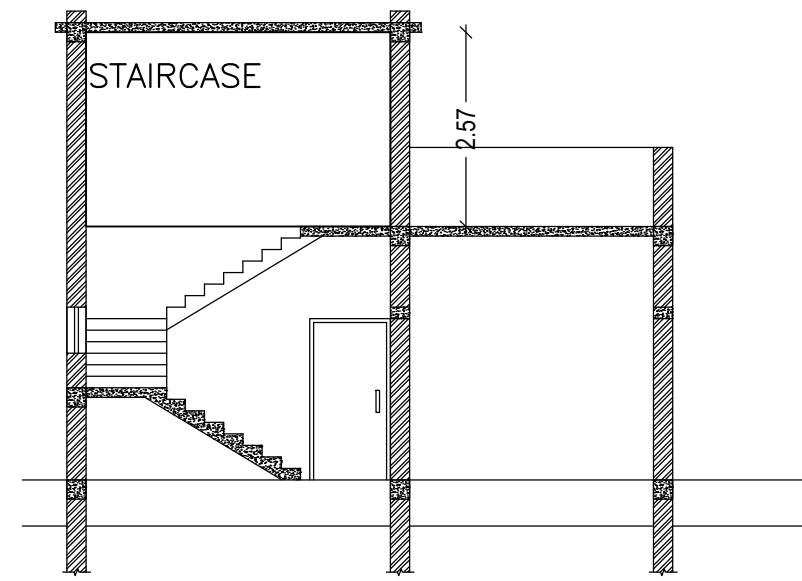
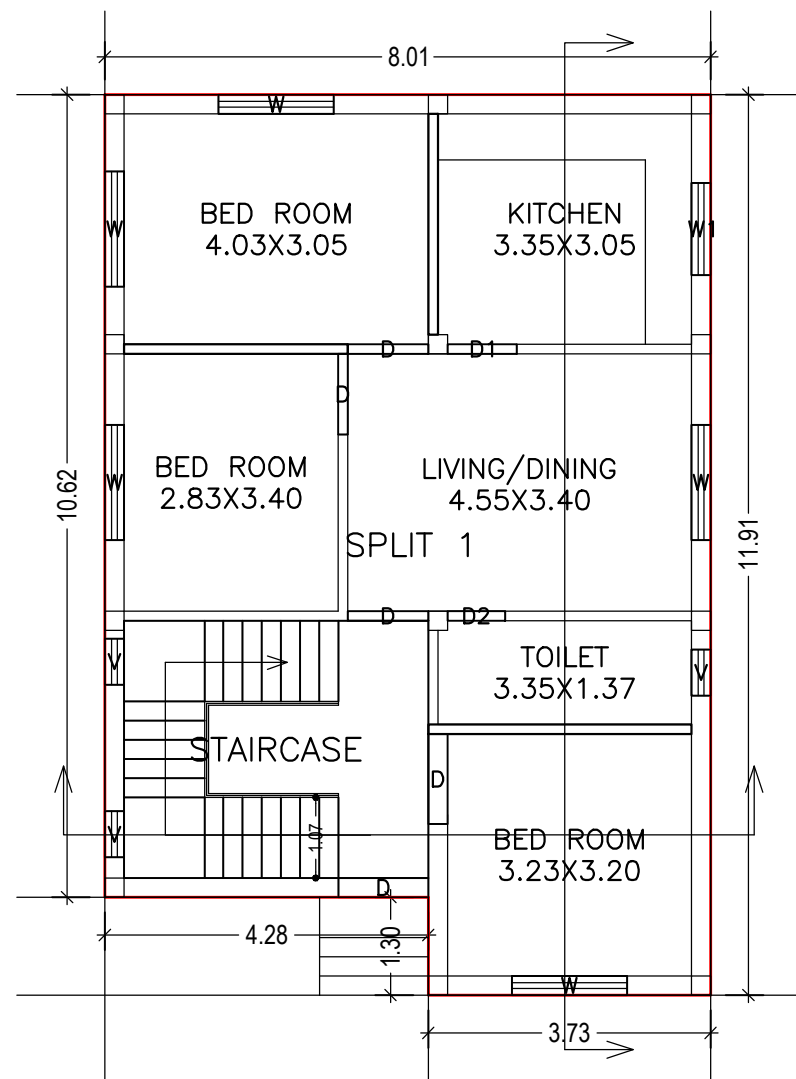

SECTION AT: X-X
SCALE 1:100

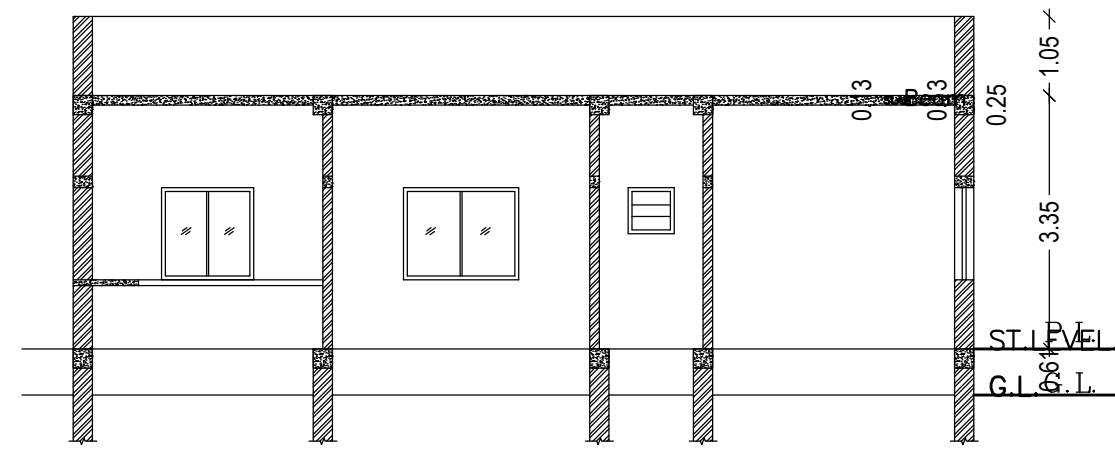

SECTION AT: Y-Y
SCALE 1:100

GROUND FLOOR PLAN
(Proposed)
(SCALE 1:100)

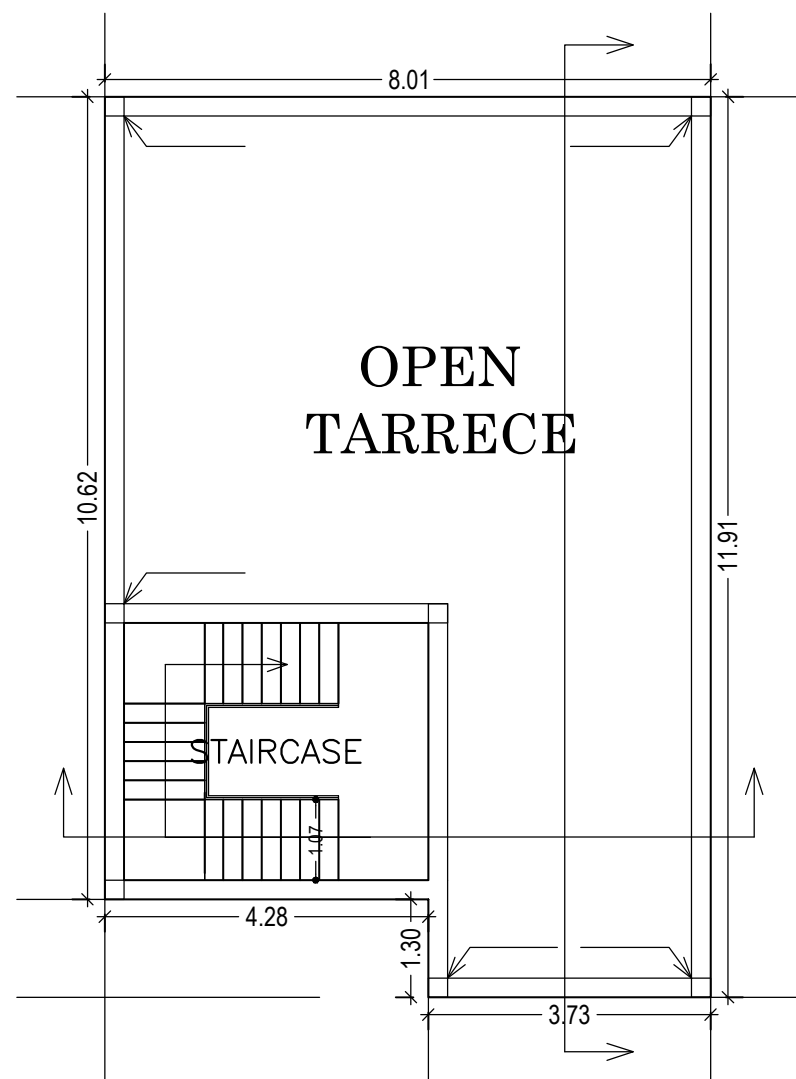

TERRACE FLOOR PLAN
(SCALE 1:100)



SITE PLAN
SCALE 1:200

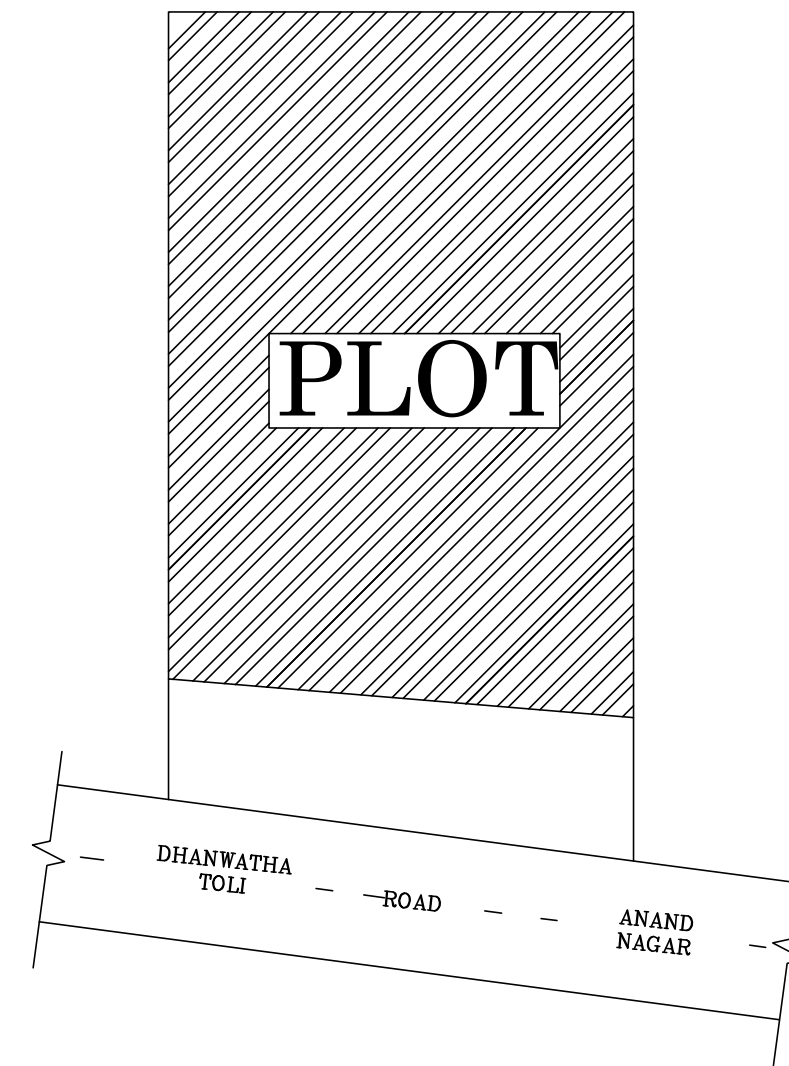

LOCATION PLAN
NOT TO SCALE

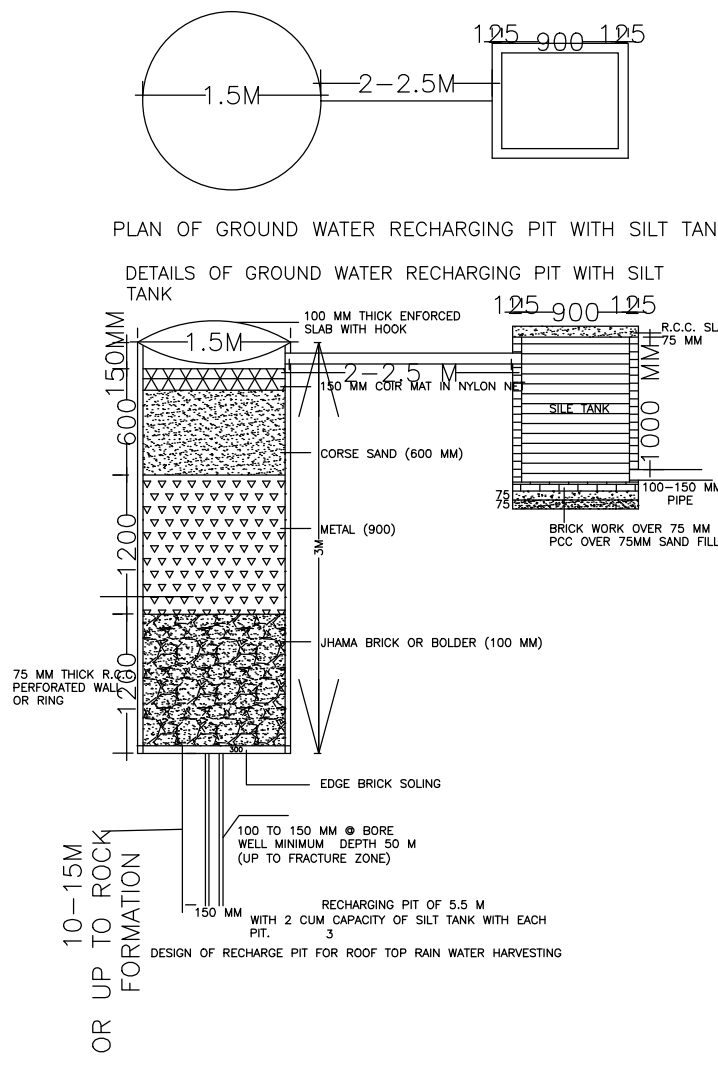

DETAILS OF GROUND WATER RECHARGING PIT WITH SILT TANK

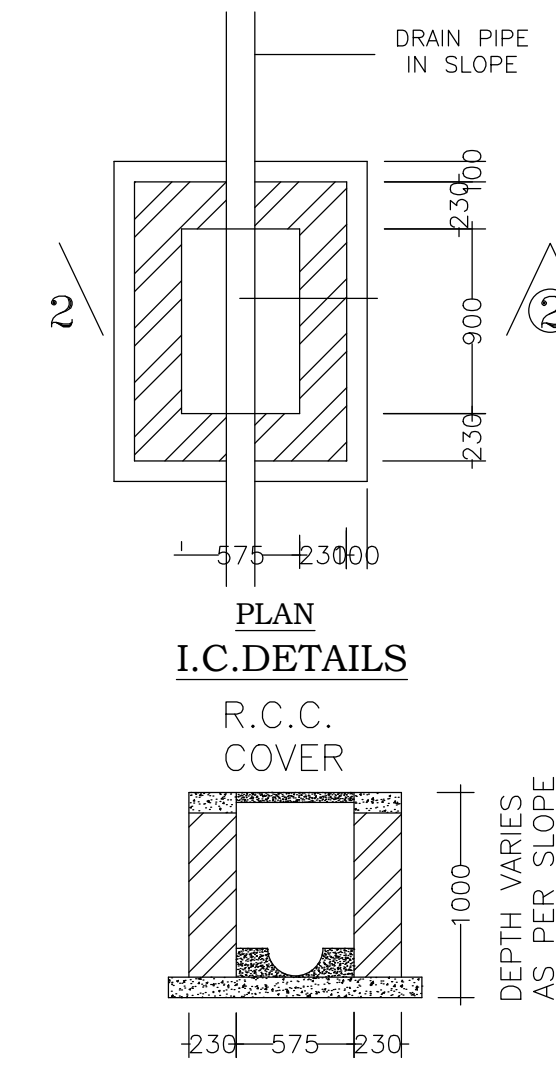

PLAN I.C. DETAILS
SECTION AT 2-2

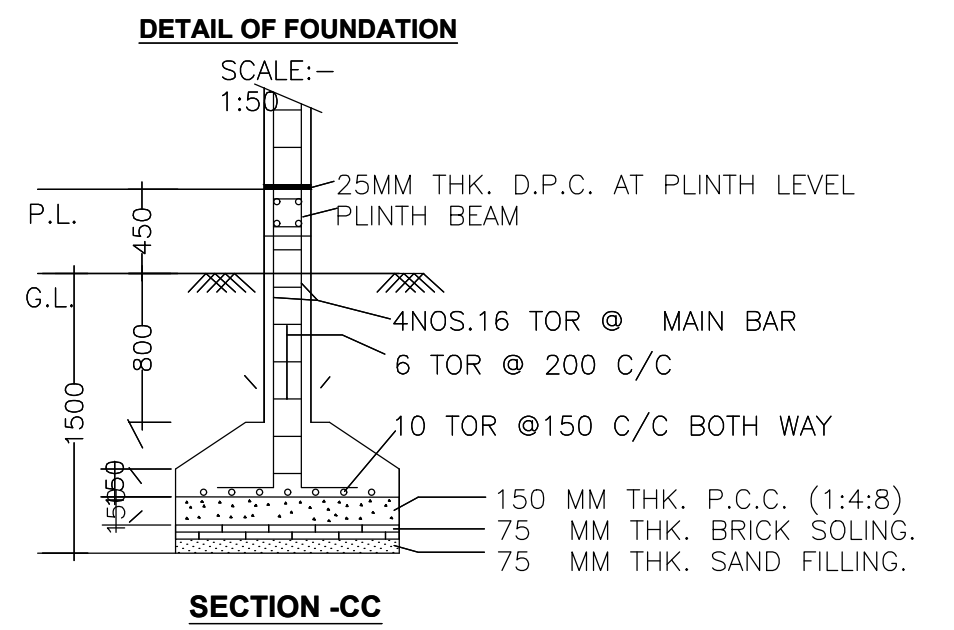
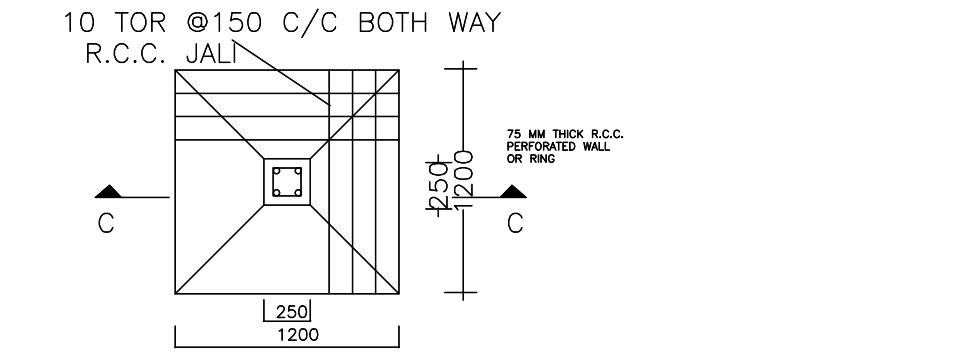

SECTION -CC

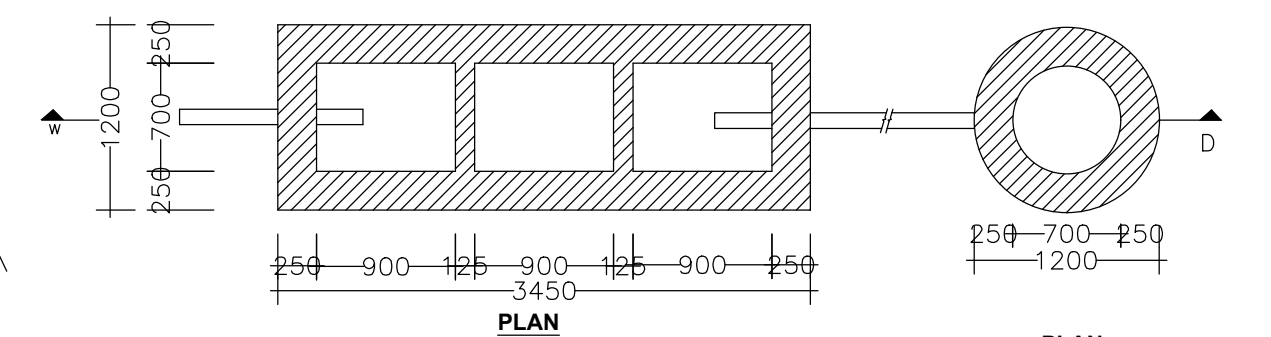

DETAIL OF SEPTIC TANK & SOAKPIT.
SCALE - 1:50

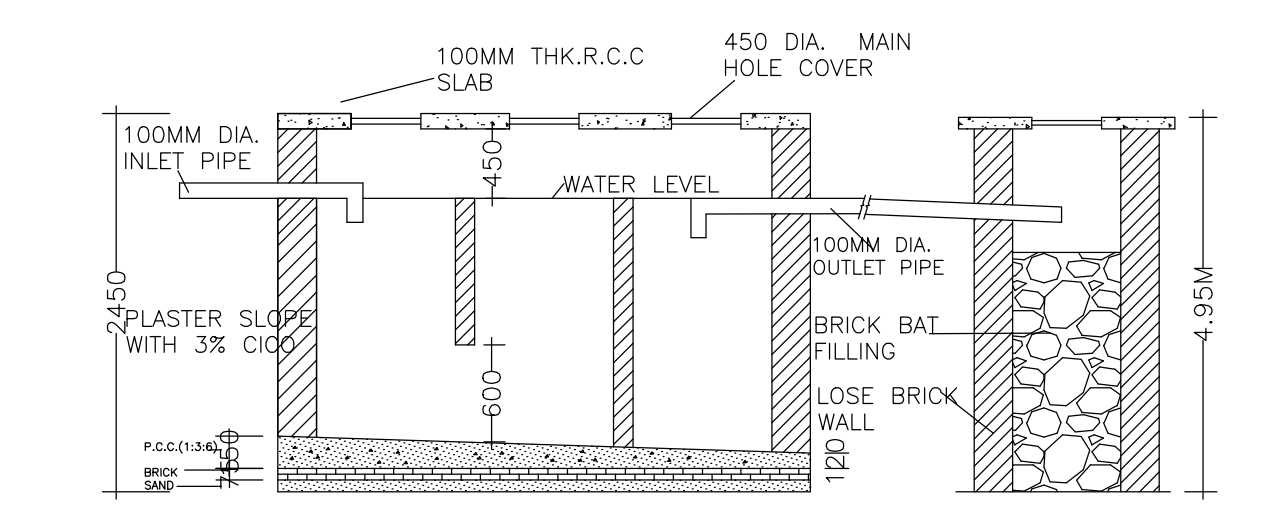

SECTION-DD

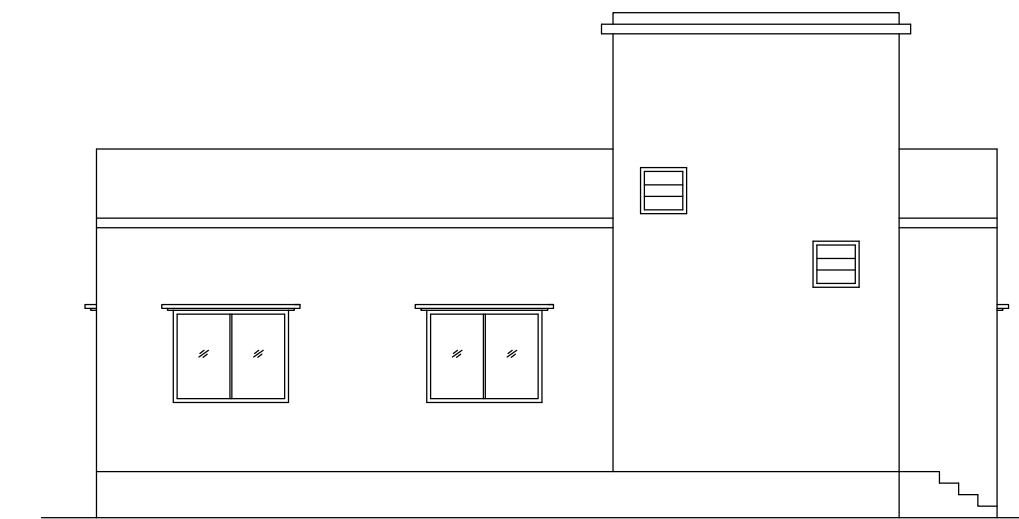

LEFT SIDE ELEVATION
SCALE 1:100

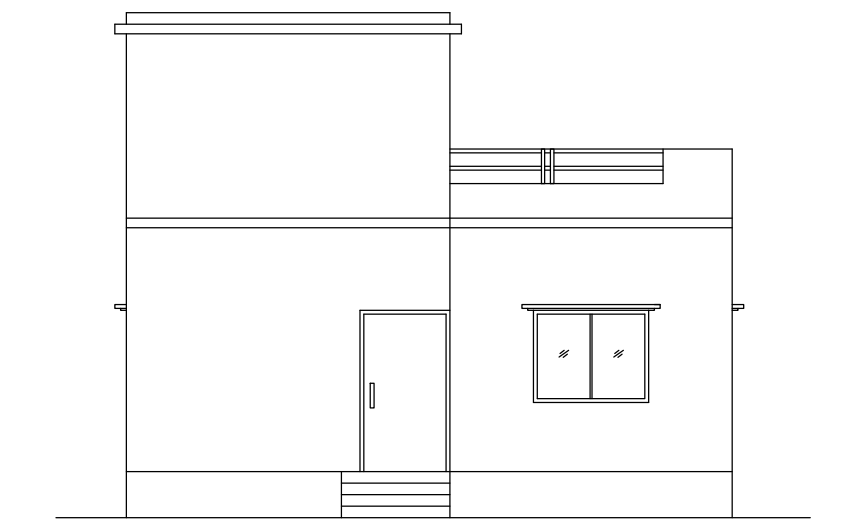

FRONT ELEVATION
SCALE 1:100

Building :A1 (RESIDENCE)

Floor Name	Total Built Up Area (Sq.mt.)	Proposed FAR Area (Sq.mt.)	Total FAR Area (Sq.mt.)	Total Consumed Additional FAR Area (Sq.mt.)	Tnmt (No.)
Ground Floor	89.91	89.91	89.91	89.91	01
Terrace Floor	0.00	0.00	0.00	0.00	00
Total :	89.91	89.91	89.91	89.91	01
Total Number of Same Buildings	1				
Total :	89.91	89.91	89.91	89.91	01

SCHEDULE OF DOOR:

BUILDING NAME	NAME	LENGTH	HEIGHT	NOS
A1 (RESIDENCE)	D2	0.76	2.10	01
A1 (RESIDENCE)	D1	0.91	2.10	01
A1 (RESIDENCE)	D	1.07	2.10	03
A1 (RESIDENCE)	D	1.19	2.10	01

SCHEDULE OF WINDOW/VENTILATION:

BUILDING NAME	NAME	LENGTH	HEIGHT	NOS
A1 (RESIDENCE)	V	0.61	1.20	03
A1 (RESIDENCE)	W1	1.22	1.20	01
A1 (RESIDENCE)	W	1.52	1.20	05

UnitBUA Table for Building :A1 (RESIDENCE)

FLOOR	Name	UnitBUA Type	UnitBUA Area	Carpet Area	No. of Rooms	No. of Tenement
GROUND FLOOR PLAN	SPLIT 1	FLAT	65.10	64.35	6	1
Total:	-	-	65.10	64.35	6	1

LTP NAME AND SIGNATURE	STRUCTURAL ENG'S NAME AND SIGNATURE	BUILDER NAME AND SIGNATURE	DIGITAL SIGNATURE
RAJESH KUMAR SINPC/DFTMN/006/2017			